

8-Bit Shift Register with Output Latches

74VHC595

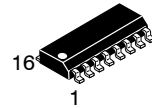

SOIC-16
D SUFFIX
CASE 751BG

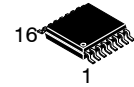

TSSOP-16
DT SUFFIX
CASE 948AH

General Description

The VHC595 is an advanced high-speed CMOS Shift Register fabricated with silicon gate CMOS technology. It achieves the high-speed operation similar to equivalent Bipolar Schottky TTL while maintaining the CMOS low power dissipation.

This device contains an 8-bit serial-in, parallel-out shift register that feeds an 8-bit D-type storage register. The storage register has eight 3-STATE outputs. Separate clocks are provided for both the shift register and the storage register. The shift register has a direct-overriding clear, serial input, and serial output (standard) pins for cascading. Both the shift register and storage register use positive-edge triggered clocks. If both clocks are connected together, the shift register state will always be one clock pulse ahead of the storage register.

An input protection circuit insures that 0 V to 5.5 V can be applied to the input pins without regard to the supply voltage. This device can be used to interface 5 V to 3 V systems and two supply systems such as battery backup. This circuit prevents device destruction due to mismatched supply and input voltages.

Features

- High Speed: $t_{PD} = 5.4 \text{ ns}$ (Typ.) at $V_{CC} = 5 \text{ V}$
- Low Power Dissipation: $I_{CC} = 4 \mu\text{A}$ (Max.) at $T_A = 25^\circ\text{C}$
- High Noise Immunity: $V_{NIH} = V_{NIL} = 28\% V_{CC}$ (Min.)
- Power Down Protection is Provided on All Inputs
- Low Noise: $V_{OLP} = 0.9 \text{ V}$ (Typ.)
- Pin and function compatible with 74HC595
- This is a Pb-Free Device

MARKING DIAGRAMS

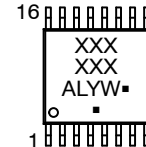
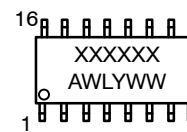

- XXX = Specific Device Code
- A = Assembly Location
- WL, L = Wafer Lot
- Y = Year
- WW, W = Work Week
- G, ■ = Pb-Free Package

(Note: Microdot may be in either location)

ORDERING INFORMATION

See detailed ordering and shipping information on page 9 of this data sheet.

74VHC595

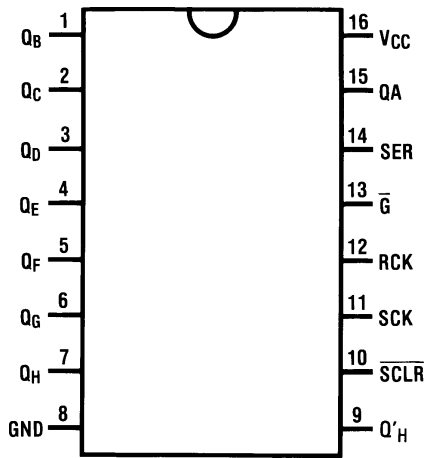

Figure 1. Connection Diagram

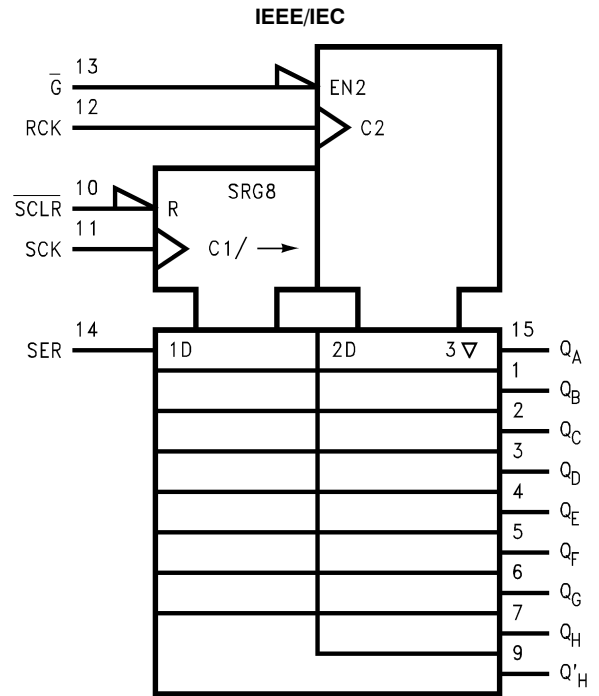

Figure 2. Logic Symbol

PIN DESCRIPTIONS

Pin Names	Description
SER	Serial Data Input
SCK	Shift Register Clock Input (Active rising edge)
RCK	Storage Register Clock Input (Active rising edge)
SCLR	Reset Input
G-bar	3-STATE Output Enable Input (Active LOW)
QA - QH	Parallel Data Outputs
Q'H	Serial Data Output

TRUTH TABLE

Inputs					Function
SER	RCK	SCK	SCLR	G-bar	
X	X	X	X	H	QA thru QH 3-STATE
X	X	X	X	L	QA thru QH outputs enabled
X	X	X	L	L	Shift Register cleared: Q'H = 0
L	X	↑	H	L	Shift Register clocked: QN = QN-1, Q0 = SER = L
H	X	↑	H	L	Shift Register clocked: QN = QN-1, Q0 = SER = H
X	↑	X	H	L	Contents of Shift Register transferred to output latches

74VHC595

Timing Diagram

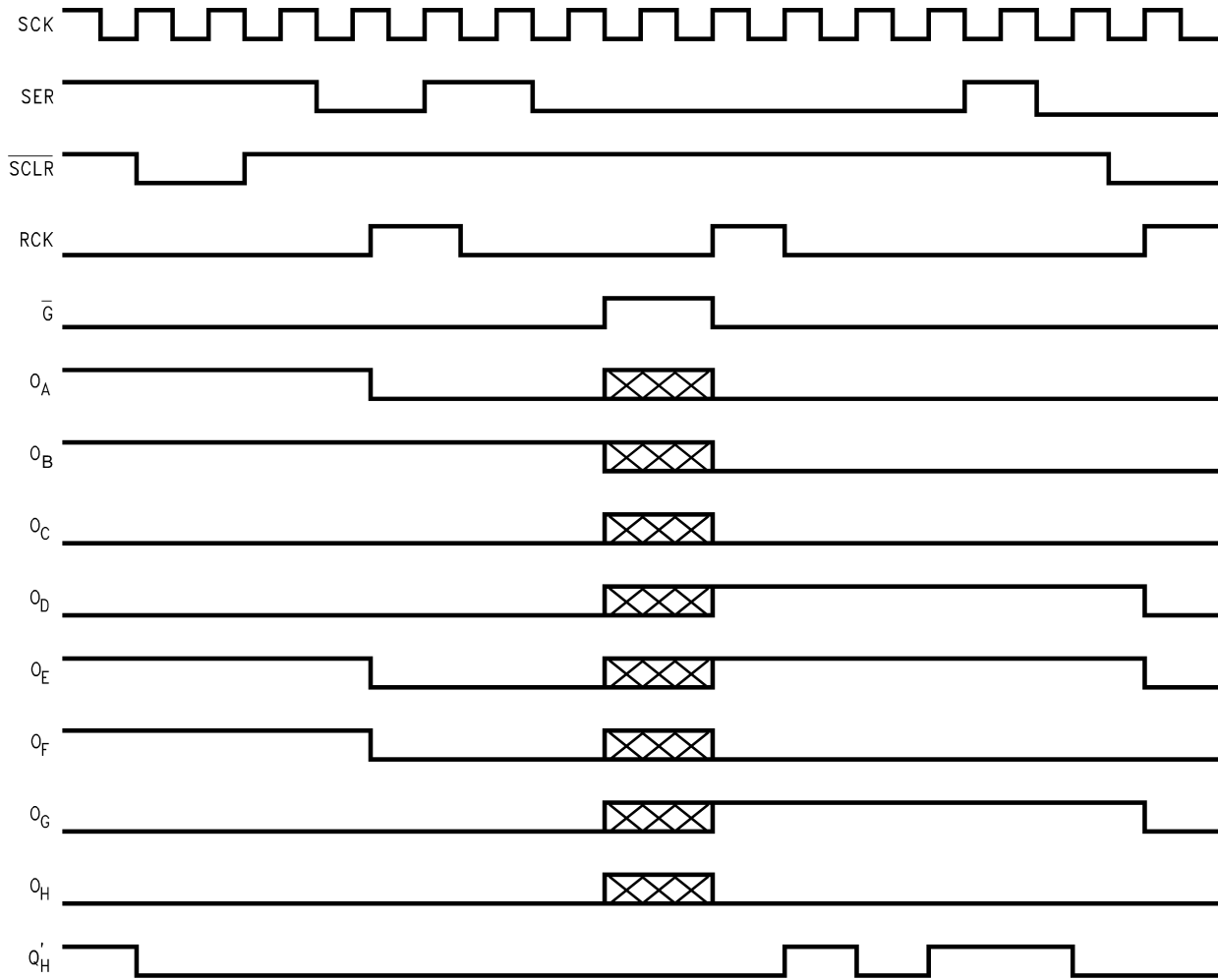

NOTE:  Implies that the output is in 3-STATE mode.

Figure 3. Timing Diagram

74VHC595

Logic Diagram (Positive Logic)

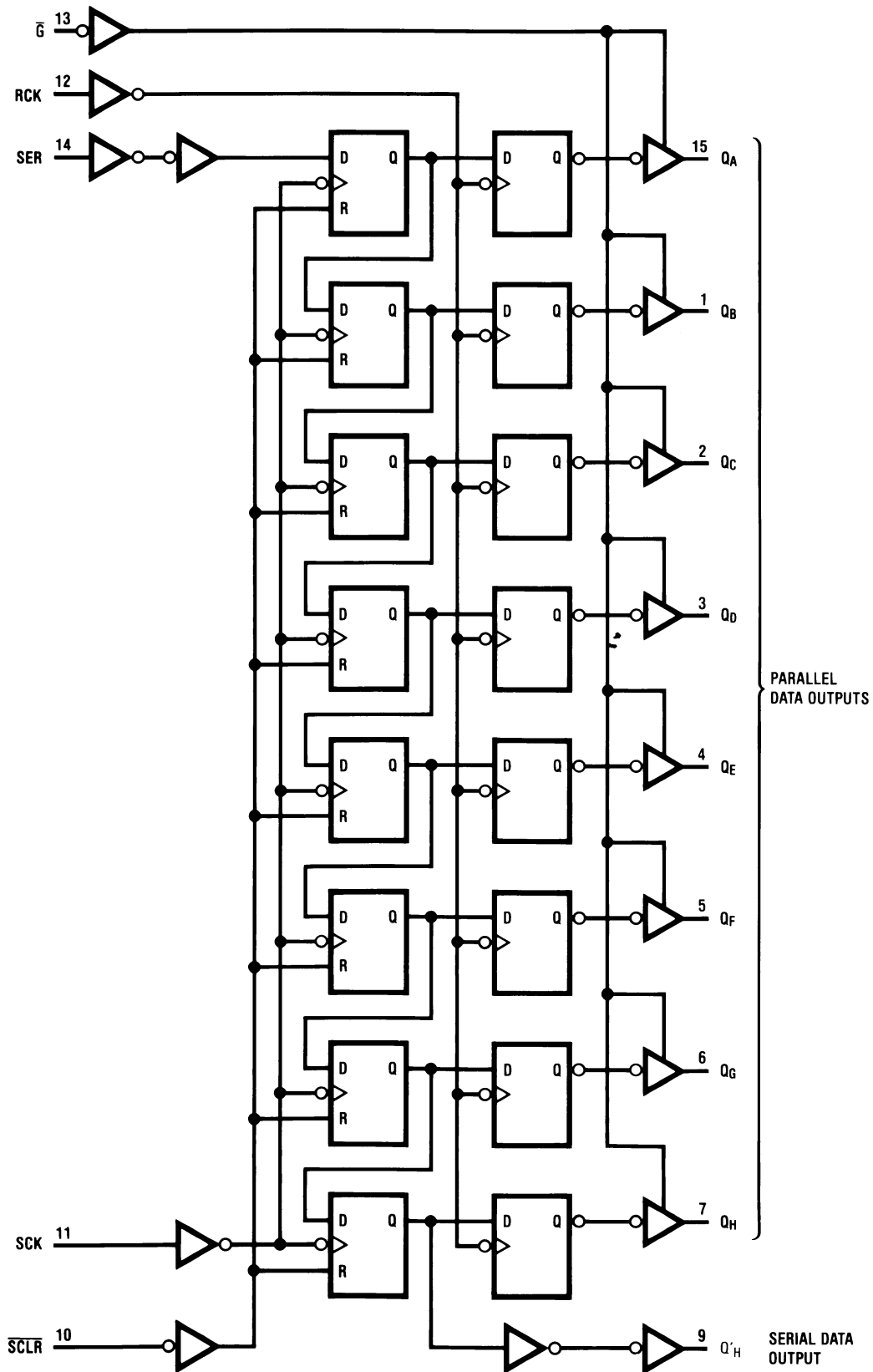

Figure 4. Logic Diagram

MAXIMUM RATINGS

Symbol	Parameter	Value	Unit	
V _{CC}	DC Supply Voltage	-0.5 to +6.5	V	
V _{IN}	DC Input Voltage	-0.5 to +6.5	V	
V _{OUT}	DC Output Voltage	-0.5 to V _{CC} +0.5	V	
I _{IN}	DC Input Current, per Pin	±20	mA	
I _{OUT}	DC Output Current, Per Pin	±25	mA	
I _{CC}	DC Supply Current, V _{CC} and GND Pins	±75	mA	
I _{IK}	Input Clamp Current	-20	mA	
I _{OK}	Output Clamp Current	±20	mA	
T _{STG}	Storage Temperature Range	-65 to +150	°C	
T _L	Lead Temperature, 1 mm from Case for 10 secs	260	°C	
T _J	Junction Temperature Under Bias	+150	°C	
θ _{JA}	Thermal Resistance (Note 2)	SOIC-16	126	°C/W
		TSSOP-16	159	
P _D	Power Dissipation in Still Air at 25°C	SOIC-16	995	mW
		TSSOP-16	787	
MSL	Moisture Sensitivity	Level 1	-	
F _R	Flammability Rating	Oxygen Index: 28 to 34	UL 94 V-0 @ 0.139 in	-
V _{ESD}	ESD Withstand Voltage (Note 3)	Human Body Model	2000	V
		Charged Device Model	N/A	

Stresses exceeding those listed in the Maximum Ratings table may damage the device. If any of these limits are exceeded, device functionality should not be assumed, damage may occur and reliability may be affected.

1. Applicable to devices with outputs that may be tri-stated.
2. Measured with minimum pad spacing on an FR4 board, using 76 mm-by-114 mm, 2-ounce copper trace no air flow per JESD51-7.
3. HBM tested to EIA / JESD22-A114-A. CDM tested to JESD22-C101-A. JEDEC recommends that ESD qualification to EIA/JESD22-A115A (Machine Model) be discontinued.

RECOMMENDED OPERATING CONDITIONS

Symbol	Parameter	Min	Max	Unit	
V _{CC}	DC Supply Voltage	2.0	5.5	V	
V _{IN}	DC Input Voltage (Note 4)	0	5.5	V	
V _{OUT}	DC Output Voltage (Note 4)	0	V _{CC}	V	
T _A	Operating Temperature	-40	+85	°C	
t _r , t _f	Input Rise or Fall Rate	V _{CC} = 3.0 V to 3.6 V	0	100	ns/V
		V _{CC} = 4.5 V to 5.5 V	0	20	

Functional operation above the stresses listed in the Recommended Operating Ranges is not implied. Extended exposure to stresses beyond the Recommended Operating Ranges limits may affect device reliability.

4. Unused inputs must always be tied to an appropriate logic voltage level (e.g., either GND or V_{CC}). Unused outputs must be left open.

74VHC595

DC ELECTRICAL CHARACTERISTICS

Symbol	Parameter	V _{CC} (V)	Conditions	T _A = 25°C			T _A = -40°C to +85°C		Unit		
				Min	Typ	Max	Min	Max			
V _{IH}	HIGH Level Input Voltage	2.0		1.5			1.5		V		
		3.0 – 5.5		0.7 × V _{CC}			0.7 × V _{CC}				
V _{IL}	LOW Level Input Voltage	2.0				0.50		0.50	V		
		3.0 – 5.5				0.3 × V _{CC}		0.3 × V _{CC}			
V _{OH}	HIGH Level Output Voltage	2.0	V _{IN} = V _{IH} or V _{IL}	I _{OH} = -50 μA	1.9	2.0		1.9		V	
		3.0			2.9	3.0		2.9			
		4.5			4.4	4.5		4.4			
		3.0		I _{OH} = -4 mA		2.58		2.48			
		4.5		I _{OH} = -8 mA		3.94		3.80			
V _{OL}	LOW Level Output Voltage	2.0	V _{IN} = V _{IH} or V _{IL}	I _{OL} = 50 μA		0.0	0.1		0.1	V	
		3.0				0.0	0.1		0.1		
		4.5				0.0	0.1		0.1		
		3.0		I _{OL} = 4 mA				0.36			0.44
		4.5		I _{OL} = 8 mA				0.36			0.44
I _{OZ}	3-STATE Output Off-State Current	5.5	V _{IN} = V _{CC} or GND, V _{OUT} = V _{CC} or GND, V _{IN} G = V _{IH} or V _{IL}			±0.25		±2.5	μA		
I _{IN}	Input Leakage Current	0 – 5.5	V _{IN} = 5.5 V or GND			±0.1		±1.0	μA		
I _{CC}	Quiescent Supply Current	5.5	V _{IN} = V _{CC} or GND			4.0		40.0	μA		

Product parametric performance is indicated in the Electrical Characteristics for the listed test conditions, unless otherwise noted. Product performance may not be indicated by the Electrical Characteristics if operated under different conditions.

NOISE CHARACTERISTICS

Symbol	Parameter	V _{CC} (V)	Conditions	T _A = 25°C		Unit
				Typ	Limits	
V _{OLP} (Note 5)	Quiet Output Maximum Dynamic V _{OL}	5.0	C _L = 50 pF	0.9	1.2	V
V _{OLV} (Note 5)	Quiet Output Minimum Dynamic V _{OL}	5.0	C _L = 50 pF	-0.9	-1.2	V
V _{IHD} (Note 5)	Minimum HIGH Level Dynamic Input Voltage	5.0	C _L = 50 pF		3.5	V
V _{ILD} (Note 5)	Maximum LOW Level Dynamic Input Voltage	5.0	C _L = 50 pF		1.5	V

5. Parameter guaranteed by design.

74VHC595

AC ELECTRICAL CHARACTERISTICS

Symbol	Parameter	V _{CC} (V)	Conditions	T _A = +25°C			T _A = -40°C to +85°C		Unit
				Min	Typ	Max	Min	Max	
t _{PLH} , t _{PHL}	Propagation Delay Time, RCK to Q _A -Q _H	3.3 ± 0.3		C _L = 15 pF	7.7	11.9	1.0	13.5	ns
				C _L = 50 pF	10.2	15.4	1.0	17.0	
		5.0 ± 0.5		C _L = 15 pF	5.4	7.4	1.0	8.5	ns
				C _L = 50 pF	6.9	9.4	1.0	10.5	
t _{PLH} , t _{PHL}	Propagation Delay Time, SCK-Q'H	3.3 ± 0.3		C _L = 15 pF	8.8	13.0	1.0	15.0	ns
				C _L = 50 pF	11.3	16.5	1.0	18.5	
		5.0 ± 0.5		C _L = 15 pF	6.2	8.2	1.0	9.4	ns
				C _L = 50 pF	7.7	10.2	1.0	11.4	
t _{PHL}	Propagation Delay Time, SCLR-Q'H	3.3 ± 0.3		C _L = 15 pF	8.4	12.8	1.0	13.7	ns
				C _L = 50 pF	10.9	16.3	1.0	17.2	
		5.0 ± 0.5		C _L = 15 pF	5.9	8.0	1.0	9.1	ns
				C _L = 50 pF	7.4	10.0	1.0	11.1	
t _{PZL} , t _{PZH}	Output Enable Time, \bar{G} to Q _A -Q _H	3.3 ± 0.3	R _L = 1 kΩ	C _L = 15 pF	7.5	11.5	1.0	13.5	ns
				C _L = 50 pF	9.0	15.0	1.0	17.0	
		5.0 ± 0.5		C _L = 15 pF	4.8	8.6	1.0	10.0	ns
				C _L = 50 pF	8.3	10.6	1.0	12.0	
t _{PLZ} , t _{PHZ}	Output Enable Time, \bar{G} to Q _A -Q _H	3.3 ± 0.3	R _L = 1 kΩ	C _L = 50 pF	12.1	15.7	1.0	16.2	ns
		5.0 ± 0.5		C _L = 50 pF	7.6	10.3	1.0	11.0	
f _{MAX}	Maximum Clock Frequency	3.3 ± 0.3		C _L = 15 pF	80	150	70		MHz
				C _L = 50 pF	55	130	50		
		5.0 ± 0.5		C _L = 15 pF	135	185	115		MHz
				C _L = 50 pF	95	155	85		
t _{OSLH} , t _{OSHL}	Output to Output Skew	3.3 ± 0.3	(Note 6)	C _L = 50 pF		1.5		1.5	ns
		5.0 ± 0.5		C _L = 50 pF		1.0		1.0	
C _{IN}	Input Capacitance		V _{CC} = Open		5.0	10		10	pF
C _{OUT}	Output Capacitance		V _{CC} = 5.0 V		6.0				pF
C _{PD}	Power Dissipation Capacitance		(Note 7)		87				pF

Product parametric performance is indicated in the Electrical Characteristics for the listed test conditions, unless otherwise noted. Product performance may not be indicated by the Electrical Characteristics if operated under different conditions.

6. Parameter guaranteed by design. t_{OSLH} = |t_{PLH} max - t_{PLH} min|; t_{OSHL} = |t_{PHL} max - t_{PHL} min|.

7. C_{PD} is defined as the value of the internal equivalent capacitance which is calculated from the operating current consumption without load. Average operating current can be obtained by the equation:

$$I_{CC} (\text{Opr.}) = C_{PD} \times V_{CC} \times f_{IN} + I_{CC}$$

AC OPERATING REQUIREMENTS

Symbol	Parameter	V _{CC} (V)	T _A = 25°C		T _A = -40°C to +85°C	Unit
			Typ	Guaranteed Minimum		
t _S	Minimum Setup Time (SER–SCK)	3.3 ± 0.3		3.5	3.5	ns
		5.0 ± 0.5		3.0	3.0	
t _S	Minimum Setup Time (SCK–RCK)	3.3 ± 0.3		8.0	8.5	ns
		5.0 ± 0.5		5.0	5.0	
t _S	Minimum Setup Time (SCLR–RCK)	3.3 ± 0.3		8.0	9.0	ns
		5.0 ± 0.5		5.0	5.0	
t _H	Minimum Hold Time (SER–SCK)	3.3 ± 0.3		1.5	1.5	ns
		5.0 ± 0.5		2.0	2.0	
t _H	Minimum Hold Time (SCK–RCK)	3.3 ± 0.3		0.0	0.0	ns
		5.0 ± 0.5		0.0	0.0	
t _H	Minimum Hold Time (SCLR–RCK)	3.3 ± 0.3		0.0	0.0	ns
		5.0 ± 0.5		0.0	0.0	
t _{W(L)}	Minimum Pulse Width (SCLR)	3.3 ± 0.3		5.0	5.0	ns
		5.0 ± 0.5		5.0	5.0	
t _{W(L)} , t _{W(H)}	Minimum Pulse Width (SCK)	3.3 ± 0.3		5.0	5.0	ns
		5.0 ± 0.5		5.0	5.0	
t _{W(L)} , t _{W(H)}	Minimum Pulse Width (RCK)	3.3 ± 0.3		5.0	5.0	ns
		5.0 ± 0.5		5.0	5.0	
t _{rem}	Minimum Removal Time (SCLR–SCK)	3.3 ± 0.3		3.0	3.0	ns
		5.0 ± 0.5		2.5	2.5	

74VHC595

ORDERING INFORMATION

Device	Marking	Package	Shipping†
74VHC595MX	VHC595G	SOIC-16	2500 Units / Tape & Reel
74VHC595MTCX	VHC 595	TSSOP-16	2500 Units / Tape & Reel

†For information on tape and reel specifications, including part orientation and tape sizes, please refer to our Tape and Reel Packaging Specifications Brochure, [BRD8011/D](#).

MECHANICAL CASE OUTLINE

PACKAGE DIMENSIONS

ON Semiconductor®



SOIC-16, 150 mils
CASE 751BG-01
ISSUE O

DATE 19 DEC 2008

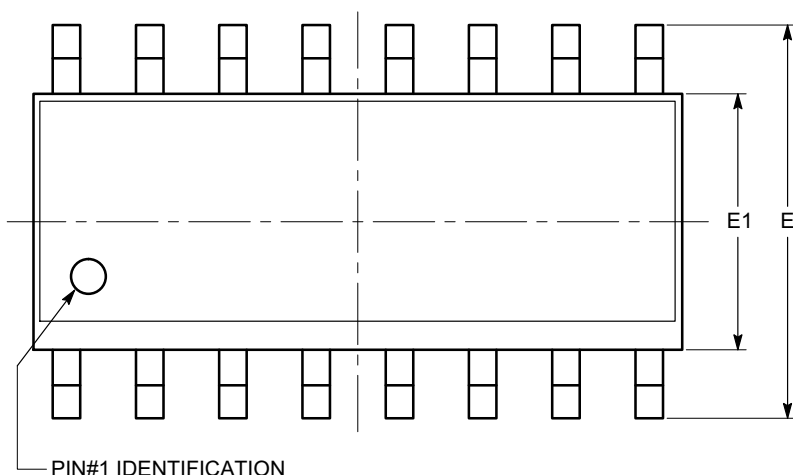

SYMBOL	MIN	NOM	MAX
A	1.35		1.75
A1	0.10		0.25
b	0.33		0.51
c	0.19		0.25
D	9.80	9.90	10.00
E	5.80	6.00	6.20
E1	3.80	3.90	4.00
e	1.27 BSC		
h	0.25		0.50
L	0.40		1.27
θ	0°		8°

TOP VIEW

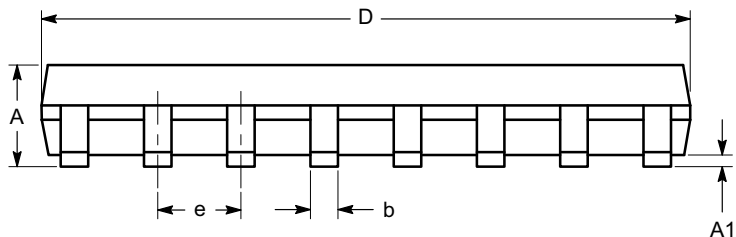

SIDE VIEW

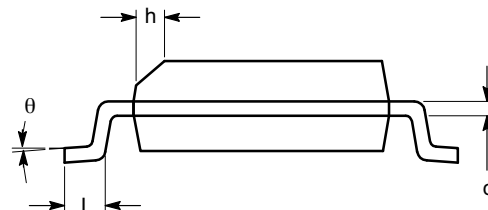

END VIEW

Notes:

- (1) All dimensions are in millimeters. Angles in degrees.
- (2) Complies with JEDEC MS-012.

DOCUMENT NUMBER:	98AON34275E	Electronic versions are uncontrolled except when accessed directly from the Document Repository. Printed versions are uncontrolled except when stamped "CONTROLLED COPY" in red.
DESCRIPTION:	SOIC-16, 150 MILS	PAGE 1 OF 1

ON Semiconductor and are trademarks of Semiconductor Components Industries, LLC dba ON Semiconductor or its subsidiaries in the United States and/or other countries. ON Semiconductor reserves the right to make changes without further notice to any products herein. ON Semiconductor makes no warranty, representation or guarantee regarding the suitability of its products for any particular purpose, nor does ON Semiconductor assume any liability arising out of the application or use of any product or circuit, and specifically disclaims any and all liability, including without limitation special, consequential or incidental damages. ON Semiconductor does not convey any license under its patent rights nor the rights of others.

TSSOP 16
CASE 948AH
ISSUE O

DATE 19 SEP 2008

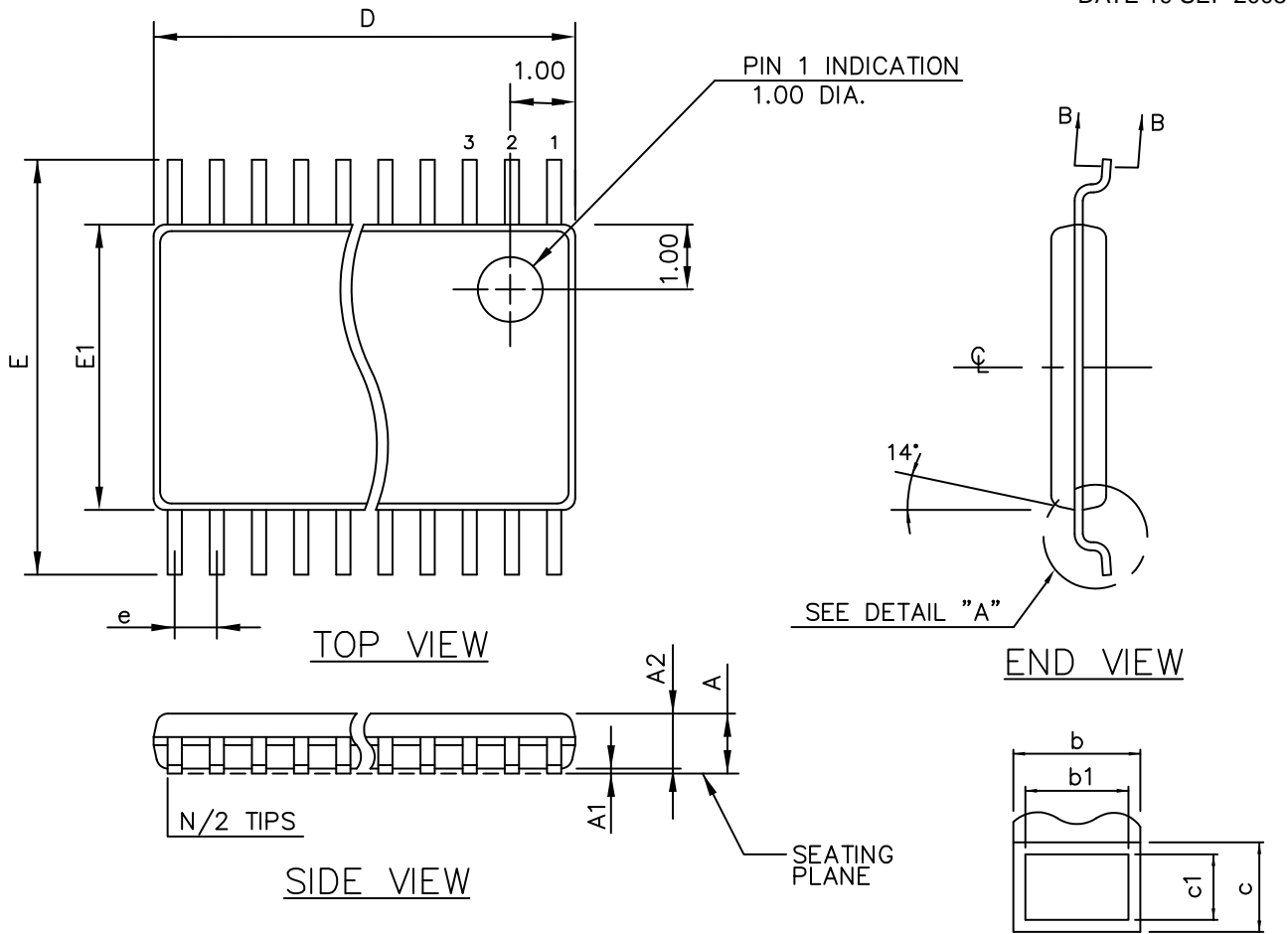

THIS TABLE FOR 0.65mm PITCH

SYMBOL	COMMON DIMENSIONS			NOTE VARIATIONS	D	N
	MIN.	NOM.	MAX.			
A	—	—	1.10	AA/AAT	3.00 BSC	8
A ₁	0.05	—	0.15	AB-1/ABT	5.00 BSC	14
A ₂	0.85	0.90	0.95	AB/ABT	5.00 BSC	16
b	0.19	—	0.30	AD/ADT	7.80 BSC	24
b ₁	0.19	0.22	0.25			
c	0.09	—	0.20			
c ₁	0.09	0.127	0.16			
D	SEE VARIATIONS					
E ₁	4.30	4.40	4.50			
e	0.65 BSC					
E	6.40 BSC					
L	0.50	0.60	0.70			
L ₁	1.00 REF					
N	SEE VARIATIONS					
X	0°	—	8°			

ALL DIMENSIONS IN MILLIMETERS

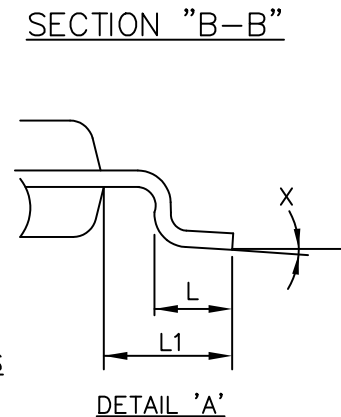

MOLD FLASH OR PROTRUSIONS SHALL NOT EXCEED 0.15mm ON D PER SIDE

DOCUMENT NUMBER:	98AON34923E	Electronic versions are uncontrolled except when accessed directly from the Document Repository. Printed versions are uncontrolled except when stamped "CONTROLLED COPY" in red.
DESCRIPTION:	TSSOP 16	PAGE 1 OF 1

onsemi and ONSEMI are trademarks of Semiconductor Components Industries, LLC dba onsemi or its subsidiaries in the United States and/or other countries. onsemi reserves the right to make changes without further notice to any products herein. onsemi makes no warranty, representation or guarantee regarding the suitability of its products for any particular purpose, nor does onsemi assume any liability arising out of the application or use of any product or circuit, and specifically disclaims any and all liability, including without limitation special, consequential or incidental damages. onsemi does not convey any license under its patent rights nor the rights of others.

onsemi, **Onsemi**, and other names, marks, and brands are registered and/or common law trademarks of Semiconductor Components Industries, LLC dba "**onsemi**" or its affiliates and/or subsidiaries in the United States and/or other countries. **onsemi** owns the rights to a number of patents, trademarks, copyrights, trade secrets, and other intellectual property. A listing of **onsemi**'s product/patent coverage may be accessed at www.onsemi.com/site/pdf/Patent-Marking.pdf. **onsemi** reserves the right to make changes at any time to any products or information herein, without notice. The information herein is provided "as-is" and **onsemi** makes no warranty, representation or guarantee regarding the accuracy of the information, product features, availability, functionality, or suitability of its products for any particular purpose, nor does **onsemi** assume any liability arising out of the application or use of any product or circuit, and specifically disclaims any and all liability, including without limitation special, consequential or incidental damages. Buyer is responsible for its products and applications using **onsemi** products, including compliance with all laws, regulations and safety requirements or standards, regardless of any support or applications information provided by **onsemi**. "Typical" parameters which may be provided in **onsemi** data sheets and/or specifications can and do vary in different applications and actual performance may vary over time. All operating parameters, including "Typicals" must be validated for each customer application by customer's technical experts. **onsemi** does not convey any license under any of its intellectual property rights nor the rights of others. **onsemi** products are not designed, intended, or authorized for use as a critical component in life support systems or any FDA Class 3 medical devices or medical devices with a same or similar classification in a foreign jurisdiction or any devices intended for implantation in the human body. Should Buyer purchase or use **onsemi** products for any such unintended or unauthorized application, Buyer shall indemnify and hold **onsemi** and its officers, employees, subsidiaries, affiliates, and distributors harmless against all claims, costs, damages, and expenses, and reasonable attorney fees arising out of, directly or indirectly, any claim of personal injury or death associated with such unintended or unauthorized use, even if such claim alleges that **onsemi** was negligent regarding the design or manufacture of the part. **onsemi** is an Equal Opportunity/Affirmative Action Employer. This literature is subject to all applicable copyright laws and is not for resale in any manner.

ADDITIONAL INFORMATION

TECHNICAL PUBLICATIONS:

Technical Library: www.onsemi.com/design/resources/technical-documentation
onsemi Website: www.onsemi.com

ONLINE SUPPORT: www.onsemi.com/support

For additional information, please contact your local Sales Representative at www.onsemi.com/support/sales