

TMUX7219 44V, Latch-Up Immune, 2:1 (SPDT) Precision Switch with 1.8V Logic

1 Features

- [Latch-up immune](#)
- Dual supply range: $\pm 4.5\text{V}$ to $\pm 22\text{V}$
- Single supply range: 4.5V to 44V
- Low on-resistance: 2.1 Ω
- Low charge injection: -10pC
- High current support: 330mA (maximum) (VSSOP)
- High current support: 440mA (maximum) (WSN)
- -40°C to +125°C operating temperature
- [1.8V logic compatible](#)
- [Fail-safe logic](#)
- [Rail-to-rail operation](#)
- [Bidirectional signal path](#)
- Break-before-make switching

2 Applications

- [Factory automation and industrial controls](#)
- [Programmable logic controllers \(PLC\)](#)
- [Analog input modules](#)
- [Semiconductor test](#)
- [AC charging \(Pile\) station](#)
- [Ultrasound scanners](#)
- [Patient monitoring and diagnostics](#)
- [Optical networking](#)
- [Optical test equipment](#)
- [Remote radio units](#)
- [Wired networking](#)
- [Data acquisition systems](#)
- [Gas meters](#)
- [Flow transmitters](#)

3 Description

The TMUX7219 is a complementary metal-oxide semiconductor (CMOS) switch with latch-up immunity in a single channel, 2:1 (SPDT) configuration. The device works with a single supply (4.5 V to 44 V), dual supplies ($\pm 4.5\text{V}$ to $\pm 22\text{V}$), or asymmetric supplies (such as $V_{DD} = 12\text{V}$, $V_{SS} = -5\text{V}$). The TMUX7219 supports bidirectional analog and digital signals on the source (S_x) and drain (D) pins ranging from V_{SS} to V_{DD} .

The TMUX7219 can be enabled or disabled by controlling the EN pin. When disabled, both signal path switches are off. When enabled, the SEL pin can be used to turn on signal path 1 (S1 to D) or signal path 2 (S2 to D). All logic control inputs support logic levels from 1.8V to V_{DD} , ensuring both TTL and CMOS logic compatibility when operating in the valid supply voltage range. [Fail-Safe Logic](#) circuitry allows voltages on the control pins to be applied before

the supply pin, protecting the device from potential damage.

The TMUX72xx family provides latch-up immunity, preventing undesirable high current events between parasitic structures within the device typically caused by overvoltage events. A latch-up condition typically continues until the power supply rails are turned off and can lead to device failure. The latch-up immunity feature allows the TMUX72xx family of switches and multiplexers to be used in harsh environments.

Device Information

PART NUMBER	PACKAGE ⁽¹⁾	BODY SIZE (NOM)
TMUX7219	VSSOP (8) DGK	3.00mm × 3.00mm
	WSN (8) RQX	3.00mm × 2.00mm

- (1) For all available packages, see the package option addendum at the end of the data sheet.

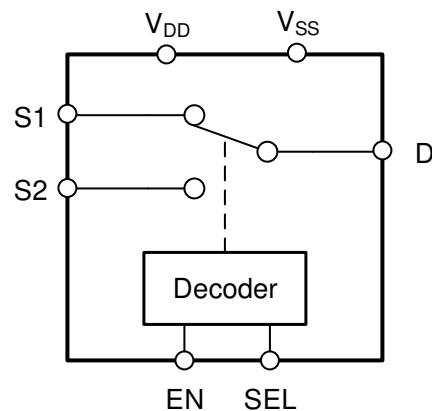

Functional Block Diagram

Table of Contents

1 Features	1	6.10 Off Isolation.....	24
2 Applications	1	6.11 Crosstalk.....	25
3 Description	1	6.12 Bandwidth.....	25
4 Pin Configuration and Functions	3	6.13 THD + Noise.....	26
5 Specifications	4	6.14 Power Supply Rejection Ratio (PSRR).....	26
5.1 Absolute Maximum Ratings.....	4	7 Detailed Description	27
5.2 ESD Ratings.....	4	7.1 Overview.....	27
5.3 Thermal Information.....	4	7.2 Functional Block Diagram.....	27
5.4 Recommended Operating Conditions.....	5	7.3 Feature Description.....	27
5.5 Source or Drain Continuous Current.....	5	7.4 Device Functional Modes.....	30
5.6 ±15 V Dual Supply: Electrical Characteristics	6	7.5 Truth Tables.....	30
5.7 ±15 V Dual Supply: Switching Characteristics	7	8 Application and Implementation	31
5.8 ±20 V Dual Supply: Electrical Characteristics	8	8.1 Application Information.....	31
5.9 ±20 V Dual Supply: Switching Characteristics.....	9	8.2 Typical Applications.....	31
5.10 44 V Single Supply: Electrical Characteristics	10	9 Power Supply Recommendations	34
5.11 44 V Single Supply: Switching Characteristics	11	10 Layout	35
5.12 12 V Single Supply: Electrical Characteristics	12	10.1 Layout Guidelines.....	35
5.13 12 V Single Supply: Switching Characteristics	13	10.2 Layout Example.....	35
5.14 Typical Characteristics.....	14	11 Device and Documentation Support	36
6 Parameter Measurement Information	20	11.1 Documentation Support.....	36
6.1 On-Resistance.....	20	11.2 Receiving Notification of Documentation Updates..	36
6.2 Off-Leakage Current.....	20	11.3 Support Resources.....	36
6.3 On-Leakage Current.....	21	11.4 Trademarks.....	36
6.4 Transition Time.....	21	11.5 Electrostatic Discharge Caution.....	36
6.5 $t_{ON(EN)}$ and $t_{OFF(EN)}$	22	11.6 Glossary.....	36
6.6 Break-Before-Make.....	22	12 Revision History	36
6.7 $t_{ON(VDD)}$ Time.....	23	13 Mechanical, Packaging, and Orderable Information	37
6.8 Propagation Delay.....	23		
6.9 Charge Injection.....	24		

4 Pin Configuration and Functions

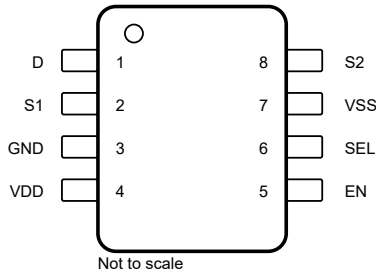

**Figure 4-1. DGK Package,
8-Pin VSSOP
(Top View)**

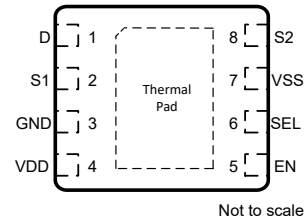

**Figure 4-2. RQX Package,
8-Pin WSON
(Top View)**

Table 4-1. Pin Functions

NAME	PIN		TYPE ⁽¹⁾	DESCRIPTION ⁽²⁾
	RQX	DGK		
D	1	1	I/O	Drain pin. Can be an input or output.
S1	2	2	I/O	Source pin 1. Can be an input or output.
GND	3	3	P	Ground (0 V) reference
V _{DD}	4	4	P	Positive power supply. This pin is the most positive power-supply potential. For reliable operation, connect a decoupling capacitor ranging from 0.1 μ F to 10 μ F between V _{DD} and GND.
EN	5	5	I	Active high logic enable, has internal pull-up resistor. When this pin is low, all switches are turned off. When this pin is high, the SEL logic input determine which switch is turned on.
SEL	6	6	I	Logic control input, has internal pull-down resistor. Controls the switch connection as shown in Section 7.5 .
V _{SS}	7	7	P	Negative power supply. This pin is the most negative power-supply potential. In single-supply applications, this pin can be connected to ground. For reliable operation, connect a decoupling capacitor ranging from 0.1 μ F to 10 μ F between V _{SS} and GND.
S2	8	8	I/O	Source pin 2. Can be an input or output.
Thermal Pad	—	—	—	The thermal pad is not connected internally. There is no requirement to electrically connect this pad. If connected, it is recommended that the pad be left floating or tied to GND.

- (1) I = input, O = output, I/O = input and output, P = power.
(2) Refer to [Section 7.4](#) for what to do with unused pins.

5 Specifications

5.1 Absolute Maximum Ratings

over operating free-air temperature range (unless otherwise noted)⁽¹⁾ ⁽³⁾

		MIN	MAX	UNIT
$V_{DD} - V_{SS}$	Supply voltage		48	V
V_{DD}		-0.5	48	V
V_{SS}		-48	0.5	V
V_{SEL} or V_{EN}	Logic control input pin voltage (SEL, EN) ⁽³⁾	-0.5	48	V
I_{SEL} or I_{EN}	Logic control input pin current (SEL, EN) ⁽³⁾	-30	30	mA
V_S or V_D	Source or drain voltage (Sx, D) ⁽³⁾	$V_{SS}-0.5$	$V_{DD}+0.5$	V
I_{IK}	Diode clamp current ⁽³⁾	-30	30	mA
I_S or I_D (CONT)	Source or drain continuous current (Sx, D)		$I_{DC} + 10\%$ ⁽⁴⁾	mA
T_A	Ambient temperature	-55	150	°C
T_{stg}	Storage temperature	-65	150	°C
T_J	Junction temperature		150	°C
P_{tot}	Total power dissipation (DGK Package) ⁽⁵⁾		460	mW
	Total power dissipation (RQX Package) ⁽⁶⁾		1110	mW

- (1) Operation outside the *Absolute Maximum Ratings* may cause permanent device damage. *Absolute Maximum Ratings* do not imply functional operation of the device at these or any other conditions beyond those listed under *Recommended Operating Conditions*. If used outside the *Recommended Operating Conditions* but within the *Absolute Maximum Ratings*, the device may not be fully functional, and this may affect device reliability, functionality, performance, and shorten the device lifetime.
- (2) All voltages are with respect to ground, unless otherwise specified.
- (3) Pins are diode-clamped to the power-supply rails. Over voltage signals must be voltage and current limited to maximum ratings.
- (4) Refer to *Source or Drain Continuous Current* table for I_{DC} specifications.
- (5) For DGK package: P_{tot} derates linearly above $T_A = 70^\circ\text{C}$ by 6.7mW/°C.
- (6) For RQX package: P_{tot} derates linearly above $T_A = 70^\circ\text{C}$ by 16mW/°C.

5.2 ESD Ratings

			VALUE	UNIT
$V_{(ESD)}$	Electrostatic discharge	Human body model (HBM), per ANSI/ESDA/ JEDEC JS-001, all pins ⁽¹⁾	±2000	V
		Charged device model (CDM), ANSI/ESDA/ JEDEC JS-002, all pins ⁽²⁾	±500	

- (1) JEDEC document JEP155 states that 500-V HBM allows safe manufacturing with a standard ESD control process.
- (2) JEDEC document JEP157 states that 250-V CDM allows safe manufacturing with a standard ESD control process.

5.3 Thermal Information

THERMAL METRIC ⁽¹⁾		TMUX7219	TMUX7219	UNIT
		DGK (VSSOP)	RQX (WSON)	
		8 PINS	8 PINS	
$R_{\theta JA}$	Junction-to-ambient thermal resistance	152.1	62.9	°C/W
$R_{\theta JC(top)}$	Junction-to-case (top) thermal resistance	48.4	54.0	°C/W
$R_{\theta JB}$	Junction-to-board thermal resistance	73.2	31.0	°C/W
Ψ_{JT}	Junction-to-top characterization parameter	4.1	0.8	°C/W
Ψ_{JB}	Junction-to-board characterization parameter	71.8	30.9	°C/W
$R_{\theta JC(bot)}$	Junction-to-case (bottom) thermal resistance	N/A	23.4	°C/W

- (1) For more information about traditional and new thermal metrics, see the [Semiconductor and IC Package Thermal Metrics](#) application report.

5.4 Recommended Operating Conditions

over operating free-air temperature range (unless otherwise noted)

		MIN	NOM	MAX	UNIT
$V_{DD} - V_{SS}$ ⁽¹⁾	Power supply voltage differential	4.5		44	V
V_{DD}	Positive power supply voltage	4.5		44	V
V_S or V_D	Signal path input/output voltage (source or drain pin) (Sx, D)	V_{SS}		V_{DD}	V
V_{SEL} or V_{EN}	Address or enable pin voltage	0		44	V
I_S or I_D (CONT)	Source or drain continuous current (Sx, D)			I_{DC} ⁽²⁾	mA
T_A	Ambient temperature	-40		125	°C

(1) V_{DD} and V_{SS} can be any value as long as $4.5\text{ V} \leq (V_{DD} - V_{SS}) \leq 44\text{ V}$, and the minimum V_{DD} is met.

(2) Refer to *Source or Drain Continuous Current* table for I_{DC} specifications.

5.5 Source or Drain Continuous Current

at supply voltage of $V_{DD} \pm 10\%$, $V_{SS} \pm 10\%$ (unless otherwise noted)

CONTINUOUS CURRENT PER CHANNEL (I_{DC})		$T_A = 25^\circ\text{C}$	$T_A = 85^\circ\text{C}$	$T_A = 125^\circ\text{C}$	UNIT
PACKAGE	TEST CONDITIONS				
RQX (WSON)	+44 V Single Supply ⁽¹⁾	440	270	130	mA
	$\pm 15\text{ V}$ Dual Supply	440	270	130	mA
	+12 V Single Supply	330	200	105	mA
	$\pm 5\text{ V}$ Dual Supply	330	200	105	mA
	+5 V Single Supply	230	140	90	mA
DGK (VSSOP)	+44 V Single Supply ⁽¹⁾	330	210	120	mA
	$\pm 15\text{ V}$ Dual Supply	330	210	120	mA
	+12 V Single Supply	240	160	100	mA
	$\pm 5\text{ V}$ Dual Supply	240	160	100	mA
	+5 V Single Supply	180	120	80	mA

(1) Specified for nominal supply voltage only.

5.6 ±15 V Dual Supply: Electrical Characteristics

$V_{DD} = +15\text{ V} \pm 10\%$, $V_{SS} = -15\text{ V} \pm 10\%$, GND = 0 V (unless otherwise noted)

Typical at $V_{DD} = +15\text{ V}$, $V_{SS} = -15\text{ V}$, $T_A = 25^\circ\text{C}$ (unless otherwise noted)

PARAMETER		TEST CONDITIONS	T_A	MIN	TYP	MAX	UNIT	
ANALOG SWITCH								
R_{ON}	On-resistance	$V_S = -10\text{ V to } +10\text{ V}$ $I_D = -10\text{ mA}$ Refer to On-Resistance	25°C		2.1	2.9	Ω	
			-40°C to +85°C			3.8	Ω	
			-40°C to +125°C			4.5	Ω	
ΔR_{ON}	On-resistance mismatch between channels	$V_S = -10\text{ V to } +10\text{ V}$ $I_D = -10\text{ mA}$ Refer to On-Resistance	25°C		0.05	0.25	Ω	
			-40°C to +85°C			0.3	Ω	
			-40°C to +125°C			0.35	Ω	
$R_{ON\ FLAT}$	On-resistance flatness	$V_S = -10\text{ V to } +10\text{ V}$ $I_S = -10\text{ mA}$ Refer to On-Resistance	25°C		0.5	0.6	Ω	
			-40°C to +85°C			0.7	Ω	
			-40°C to +125°C			0.85	Ω	
$R_{ON\ DRIFT}$	On-resistance drift	$V_S = 0\text{ V}$, $I_S = -10\text{ mA}$ Refer to On-Resistance	-40°C to +125°C		0.01		$\Omega/^\circ\text{C}$	
$I_{S(OFF)}$	Source off leakage current ⁽¹⁾	$V_{DD} = 16.5\text{ V}$, $V_{SS} = -16.5\text{ V}$ Switch state is off $V_S = +10\text{ V} / -10\text{ V}$ $V_D = -10\text{ V} / +10\text{ V}$ Refer to Off-Leakage Current	25°C	-0.15	0.05	0.15	nA	
			-40°C to +85°C		-1.6		1.6	nA
			-40°C to +125°C		-15		15	nA
$I_{D(OFF)}$	Drain off leakage current ⁽¹⁾	$V_{DD} = 16.5\text{ V}$, $V_{SS} = -16.5\text{ V}$ Switch state is off $V_S = +10\text{ V} / -10\text{ V}$ $V_D = -10\text{ V} / +10\text{ V}$ Refer to Off-Leakage Current	25°C	-1	0.05	1	nA	
			-40°C to +85°C		-3		3	nA
			-40°C to +125°C		-26		26	nA
$I_{S(ON)}$ $I_{D(ON)}$	Channel on leakage current ⁽²⁾	$V_{DD} = 16.5\text{ V}$, $V_{SS} = -16.5\text{ V}$ Switch state is on $V_S = V_D = \pm 10\text{ V}$ Refer to On-Leakage Current	25°C	-1	0.04	1	nA	
			-40°C to +85°C		-1.8		1.8	nA
			-40°C to +125°C		-18		18	nA
LOGIC INPUTS (SEL / EN pins)								
V_{IH}	Logic voltage high		-40°C to +125°C	1.3		44	V	
V_{IL}	Logic voltage low		-40°C to +125°C	0		0.8	V	
I_{IH}	Input leakage current		-40°C to +125°C		0.005	2	μA	
I_{IL}	Input leakage current		-40°C to +125°C	-1	-0.005		μA	
C_{IN}	Logic input capacitance		-40°C to +125°C		3		pF	
POWER SUPPLY								
I_{DD}	V_{DD} supply current	$V_{DD} = 16.5\text{ V}$, $V_{SS} = -16.5\text{ V}$ Logic inputs = 0 V, 5 V, or V_{DD}	25°C		30	40	μA	
			-40°C to +85°C			48	μA	
			-40°C to +125°C			62	μA	
I_{SS}	V_{SS} supply current	$V_{DD} = 16.5\text{ V}$, $V_{SS} = -16.5\text{ V}$ Logic inputs = 0 V, 5 V, or V_{DD}	25°C		3	10	μA	
			-40°C to +85°C			15	μA	
			-40°C to +125°C			25	μA	

(1) When V_S is positive, V_D is negative, or when V_S is negative, V_D is positive.

(2) When V_S is at a voltage potential, V_D is floating, or when V_D is at a voltage potential, V_S is floating.

5.7 ±15 V Dual Supply: Switching Characteristics

$V_{DD} = +15\text{ V} \pm 10\%$, $V_{SS} = -15\text{ V} \pm 10\%$, GND = 0 V (unless otherwise noted)

Typical at $V_{DD} = +15\text{ V}$, $V_{SS} = -15\text{ V}$, $T_A = 25^\circ\text{C}$ (unless otherwise noted)

PARAMETER		TEST CONDITIONS	T_A	MIN	TYP	MAX	UNIT
t_{TRAN}	Transition time from control input	$V_S = 10\text{ V}$ $R_L = 300\ \Omega$, $C_L = 35\text{ pF}$ Refer to Transition Time	25°C		120	175	ns
			-40°C to +85°C			190	ns
			-40°C to +125°C			210	ns
$t_{\text{ON (EN)}}$	Turn-on time from enable	$V_S = 10\text{ V}$ $R_L = 300\ \Omega$, $C_L = 35\text{ pF}$ Refer to Turn-on and Turn-off Time	25°C		100	170	ns
			-40°C to +85°C			185	ns
			-40°C to +125°C			200	ns
$t_{\text{OFF (EN)}}$	Turn-off time from enable	$V_S = 10\text{ V}$ $R_L = 300\ \Omega$, $C_L = 35\text{ pF}$ Refer to Turn-on and Turn-off Time	25°C		100	180	ns
			-40°C to +85°C			195	ns
			-40°C to +125°C			210	ns
t_{BBM}	Break-before-make time delay	$V_S = 10\text{ V}$, $R_L = 300\ \Omega$, $C_L = 35\text{ pF}$ Refer to Break-Before-Make	25°C		50		ns
			-40°C to +85°C		1		ns
			-40°C to +125°C		1		ns
$T_{\text{ON (VDD)}}$	Device turn on time (V_{DD} to output)	V_{DD} rise time = 100ns $R_L = 300\ \Omega$, $C_L = 35\text{ pF}$ Refer to Turn-on (VDD) Time	25°C		0.19		ms
			-40°C to +85°C			0.2	ms
			-40°C to +125°C			0.2	ms
t_{PD}	Propagation delay	$R_L = 50\ \Omega$, $C_L = 5\text{ pF}$ Refer to Propagation Delay	25°C		700		ps
Q_{INJ}	Charge injection	$V_D = 0\text{ V}$, $C_L = 1\text{ nF}$ Refer to Charge Injection	25°C		-10		pC
O_{ISO}	Off-isolation	$R_L = 50\ \Omega$, $C_L = 5\text{ pF}$ $V_S = 0\text{ V}$, $f = 100\text{ kHz}$ Refer to Off Isolation	25°C		-75		dB
O_{ISO}	Off-isolation	$R_L = 50\ \Omega$, $C_L = 5\text{ pF}$ $V_S = 0\text{ V}$, $f = 1\text{ MHz}$ Refer to Off Isolation	25°C		-55		dB
X_{TALK}	Crosstalk	$R_L = 50\ \Omega$, $C_L = 5\text{ pF}$ $V_S = 0\text{ V}$, $f = 100\text{ kHz}$ Refer to Crosstalk	25°C		-117		dB
X_{TALK}	Crosstalk	$R_L = 50\ \Omega$, $C_L = 5\text{ pF}$ $V_S = 0\text{ V}$, $f = 1\text{ MHz}$ Refer to Crosstalk	25°C		-106		dB
BW	-3dB Bandwidth	$R_L = 50\ \Omega$, $C_L = 5\text{ pF}$ $V_S = 0\text{ V}$ Refer to Bandwidth	25°C		40		MHz
I_L	Insertion loss	$R_L = 50\ \Omega$, $C_L = 5\text{ pF}$ $V_S = 0\text{ V}$, $f = 1\text{ MHz}$	25°C		-0.18		dB
ACPSRR	AC Power Supply Rejection Ratio	$V_{\text{PP}} = 0.62\text{ V}$ on V_{DD} and V_{SS} $R_L = 50\ \Omega$, $C_L = 5\text{ pF}$, $f = 1\text{ MHz}$ Refer to ACPSRR	25°C		-64		dB
THD+N	Total Harmonic Distortion + Noise	$V_{\text{PP}} = 15\text{ V}$, $V_{\text{BIAS}} = 0\text{ V}$ $R_L = 10\text{ k}\Omega$, $C_L = 5\text{ pF}$, $f = 20\text{ Hz}$ to 20 kHz Refer to THD + Noise	25°C		0.0005		%
$C_{\text{S(OFF)}}$	Source off capacitance	$V_S = 0\text{ V}$, $f = 1\text{ MHz}$	25°C		33		pF
$C_{\text{D(OFF)}}$	Drain off capacitance	$V_S = 0\text{ V}$, $f = 1\text{ MHz}$	25°C		48		pF
$C_{\text{S(ON)}}$, $C_{\text{D(ON)}}$	On capacitance	$V_S = 0\text{ V}$, $f = 1\text{ MHz}$	25°C		148		pF

5.8 ±20 V Dual Supply: Electrical Characteristics

$V_{DD} = +20\text{ V} \pm 10\%$, $V_{SS} = -20\text{ V} \pm 10\%$, GND = 0 V (unless otherwise noted)

Typical at $V_{DD} = +20\text{ V}$, $V_{SS} = -20\text{ V}$, $T_A = 25^\circ\text{C}$ (unless otherwise noted)

PARAMETER		TEST CONDITIONS	T_A	MIN	TYP	MAX	UNIT	
ANALOG SWITCH								
R_{ON}	On-resistance	$V_S = -15\text{ V to }+15\text{ V}$ $I_D = -10\text{ mA}$ Refer to On-Resistance	25°C		1.9	2.7	Ω	
			-40°C to +85°C			3.5	Ω	
			-40°C to +125°C			4.2	Ω	
ΔR_{ON}	On-resistance mismatch between channels	$V_S = -15\text{ V to }+15\text{ V}$ $I_D = -10\text{ mA}$ Refer to On-Resistance	25°C		0.04	0.22	Ω	
			-40°C to +85°C			0.28	Ω	
			-40°C to +125°C			0.3	Ω	
$R_{ON\ FLAT}$	On-resistance flatness	$V_S = -15\text{ V to }+15\text{ V}$ $I_S = -10\text{ mA}$ Refer to On-Resistance	25°C		0.3	0.75	Ω	
			-40°C to +85°C			0.9	Ω	
			-40°C to +125°C			1.2	Ω	
$R_{ON\ DRIFT}$	On-resistance drift	$V_S = 0\text{ V}$, $I_S = -10\text{ mA}$ Refer to On-Resistance	-40°C to +125°C		0.009		$\Omega/^\circ\text{C}$	
$I_{S(OFF)}$	Source off leakage current ⁽¹⁾	$V_{DD} = 22\text{ V}$, $V_{SS} = -22\text{ V}$ Switch state is off $V_S = +15\text{ V} / -15\text{ V}$ $V_D = -15\text{ V} / +15\text{ V}$ Refer to Off-Leakage Current	25°C	-1.5	0.05	1.5	nA	
			-40°C to +85°C		-4		4	nA
			-40°C to +125°C		-24		24	nA
$I_{D(OFF)}$	Drain off leakage current ⁽¹⁾	$V_{DD} = 22\text{ V}$, $V_{SS} = -22\text{ V}$ Switch state is off $V_S = +15\text{ V} / -15\text{ V}$ $V_D = -15\text{ V} / +15\text{ V}$ Refer to Off-Leakage Current	25°C	-2	0.1	2	nA	
			-40°C to +85°C		-8		8	nA
			-40°C to +125°C		-44		44	nA
$I_{S(ON)}$ $I_{D(ON)}$	Channel on leakage current ⁽²⁾	$V_{DD} = 22\text{ V}$, $V_{SS} = -22\text{ V}$ Switch state is on $V_S = V_D = \pm 15\text{ V}$ Refer to On-Leakage Current	25°C	-2	0.1	2	nA	
			-40°C to +85°C		-5		5	nA
			-40°C to +125°C		-29		29	nA
LOGIC INPUTS (SEL / EN pins)								
V_{IH}	Logic voltage high		-40°C to +125°C	1.3		44	V	
V_{IL}	Logic voltage low		-40°C to +125°C	0		0.8	V	
I_{IH}	Input leakage current		-40°C to +125°C		0.005	2	μA	
I_{IL}	Input leakage current		-40°C to +125°C	-1	-0.005		μA	
C_{IN}	Logic input capacitance		-40°C to +125°C		3		pF	
POWER SUPPLY								
I_{DD}	V_{DD} supply current	$V_{DD} = 22\text{ V}$, $V_{SS} = -22\text{ V}$ Logic inputs = 0 V, 5 V, or V_{DD}	25°C		34	44	μA	
			-40°C to +85°C			50	μA	
			-40°C to +125°C			65	μA	
I_{SS}	V_{SS} supply current	$V_{DD} = 22\text{ V}$, $V_{SS} = -22\text{ V}$ Logic inputs = 0 V, 5 V, or V_{DD}	25°C		4	9	μA	
			-40°C to +85°C			12	μA	
			-40°C to +125°C			25	μA	

(1) When V_S is positive, V_D is negative, or when V_S is negative, V_D is positive.

(2) When V_S is at a voltage potential, V_D is floating, or when V_D is at a voltage potential, V_S is floating.

5.9 ±20 V Dual Supply: Switching Characteristics

$V_{DD} = +20\text{ V} \pm 10\%$, $V_{SS} = -20\text{ V} \pm 10\%$, GND = 0 V (unless otherwise noted)

Typical at $V_{DD} = +20\text{ V}$, $V_{SS} = -20\text{ V}$, $T_A = 25^\circ\text{C}$ (unless otherwise noted)

PARAMETER		TEST CONDITIONS	T_A	MIN	TYP	MAX	UNIT
t_{TRAN}	Transition time from control input	$V_S = 10\text{ V}$ $R_L = 300\ \Omega$, $C_L = 35\text{ pF}$ Refer to Transition Time	25°C		110	175	ns
			-40°C to +85°C			190	ns
			-40°C to +125°C			205	ns
$t_{\text{ON (EN)}}$	Turn-on time from enable	$V_S = 10\text{ V}$ $R_L = 300\ \Omega$, $C_L = 35\text{ pF}$ Refer to Turn-on and Turn-off Time	25°C		110	170	ns
			-40°C to +85°C			185	ns
			-40°C to +125°C			200	ns
$t_{\text{OFF (EN)}}$	Turn-off time from enable	$V_S = 10\text{ V}$ $R_L = 300\ \Omega$, $C_L = 35\text{ pF}$ Refer to Turn-on and Turn-off Time	25°C		90	180	ns
			-40°C to +85°C			190	ns
			-40°C to +125°C			200	ns
t_{BBM}	Break-before-make time delay	$V_S = 10\text{ V}$, $R_L = 300\ \Omega$, $C_L = 35\text{ pF}$ Refer to Break-Before-Make	25°C		55		ns
			-40°C to +85°C		1		ns
			-40°C to +125°C		1		ns
$T_{\text{ON (VDD)}}$	Device turn on time (V_{DD} to output)	V_{DD} rise time = 100ns $R_L = 300\ \Omega$, $C_L = 35\text{ pF}$ Refer to Turn-on (VDD) Time	25°C		0.18		ms
			-40°C to +85°C			0.2	ms
			-40°C to +125°C			0.2	ms
t_{PD}	Propagation delay	$R_L = 50\ \Omega$, $C_L = 5\text{ pF}$ Refer to Propagation Delay	25°C		715		ps
Q_{INJ}	Charge injection	$V_D = 0\text{ V}$, $C_L = 1\text{ nF}$ Refer to Charge Injection	25°C		-15		pC
O_{ISO}	Off-isolation	$R_L = 50\ \Omega$, $C_L = 5\text{ pF}$ $V_S = 0\text{ V}$, $f = 100\text{ kHz}$ Refer to Off Isolation	25°C		-75		dB
O_{ISO}	Off-isolation	$R_L = 50\ \Omega$, $C_L = 5\text{ pF}$ $V_S = 0\text{ V}$, $f = 1\text{ MHz}$ Refer to Off Isolation	25°C		-55		dB
X_{TALK}	Crosstalk	$R_L = 50\ \Omega$, $C_L = 5\text{ pF}$ $V_S = 0\text{ V}$, $f = 100\text{ kHz}$ Refer to Crosstalk	25°C		-117		dB
X_{TALK}	Crosstalk	$R_L = 50\ \Omega$, $C_L = 5\text{ pF}$ $V_S = 0\text{ V}$, $f = 1\text{ MHz}$ Refer to Crosstalk	25°C		-106		dB
BW	-3dB Bandwidth	$R_L = 50\ \Omega$, $C_L = 5\text{ pF}$ $V_S = 0\text{ V}$, Refer to Bandwidth	25°C		38		MHz
I_L	Insertion loss	$R_L = 50\ \Omega$, $C_L = 5\text{ pF}$ $V_S = 0\text{ V}$, $f = 1\text{ MHz}$	25°C		-0.16		dB
ACPSRR	AC Power Supply Rejection Ratio	$V_{\text{PP}} = 0.62\text{ V}$ on V_{DD} and V_{SS} $R_L = 50\ \Omega$, $C_L = 5\text{ pF}$, $f = 1\text{ MHz}$ Refer to ACPSRR	25°C		-63		dB
THD+N	Total Harmonic Distortion + Noise	$V_{\text{PP}} = 20\text{ V}$, $V_{\text{BIAS}} = 0\text{ V}$ $R_L = 10\text{ k}\Omega$, $C_L = 5\text{ pF}$, $f = 20\text{ Hz}$ to 20 kHz Refer to THD + Noise	25°C		0.0005		%
$C_{\text{S(OFF)}}$	Source off capacitance	$V_S = 0\text{ V}$, $f = 1\text{ MHz}$	25°C		32		pF
$C_{\text{D(OFF)}}$	Drain off capacitance	$V_S = 0\text{ V}$, $f = 1\text{ MHz}$	25°C		45		pF
$C_{\text{S(ON)}}$, $C_{\text{D(ON)}}$	On capacitance	$V_S = 0\text{ V}$, $f = 1\text{ MHz}$	25°C		146		pF

5.10 44 V Single Supply: Electrical Characteristics

$V_{DD} = +44\text{ V}$, $V_{SS} = 0\text{ V}$, $GND = 0\text{ V}$ (unless otherwise noted)

Typical at $V_{DD} = +44\text{ V}$, $V_{SS} = 0\text{ V}$, $T_A = 25^\circ\text{C}$ (unless otherwise noted)

PARAMETER		TEST CONDITIONS	T_A	MIN	TYP	MAX	UNIT	
ANALOG SWITCH								
R_{ON}	On-resistance	$V_S = 0\text{ V to }40\text{ V}$ $I_D = -10\text{ mA}$ Refer to On-Resistance	25°C		2.2	2.8	Ω	
			-40°C to +85°C			3.6	Ω	
			-40°C to +125°C			4.2	Ω	
ΔR_{ON}	On-resistance mismatch between channels	$V_S = 0\text{ V to }40\text{ V}$ $I_D = -10\text{ mA}$ Refer to On-Resistance	25°C		0.1	0.2	Ω	
			-40°C to +85°C			0.3	Ω	
			-40°C to +125°C			0.35	Ω	
$R_{ON\ FLAT}$	On-resistance flatness	$V_S = 0\text{ V to }40\text{ V}$ $I_D = -10\text{ mA}$ Refer to On-Resistance	25°C		0.2	1	Ω	
			-40°C to +85°C			1.3	Ω	
			-40°C to +125°C			1.5	Ω	
$R_{ON\ DRIFT}$	On-resistance drift	$V_S = 22\text{ V}$, $I_S = -10\text{ mA}$ Refer to On-Resistance	-40°C to +125°C		0.008		$\Omega/^\circ\text{C}$	
$I_{S(OFF)}$	Source off leakage current ⁽¹⁾	$V_{DD} = 44\text{ V}$, $V_{SS} = 0\text{ V}$ Switch state is off $V_S = 40\text{ V} / 1\text{ V}$ $V_D = 1\text{ V} / 40\text{ V}$ Refer to Off-Leakage Current	25°C	-5	0.05	5	nA	
			-40°C to +85°C		-10		10	nA
			-40°C to +125°C		-35		35	nA
$I_{D(OFF)}$	Drain off leakage current ⁽¹⁾	$V_{DD} = 44\text{ V}$, $V_{SS} = 0\text{ V}$ Switch state is off $V_S = 40\text{ V} / 1\text{ V}$ $V_D = 1\text{ V} / 40\text{ V}$ Refer to Off-Leakage Current	25°C	-8	0.05	8	nA	
			-40°C to +85°C		-12		12	nA
			-40°C to +125°C		-70		70	nA
$I_{S(ON)}$ $I_{D(ON)}$	Channel on leakage current ⁽²⁾	$V_{DD} = 44\text{ V}$, $V_{SS} = 0\text{ V}$ Switch state is on $V_S = V_D = 40\text{ V}$ or 1 V Refer to On-Leakage Current	25°C	-8	0.05	8	nA	
			-40°C to +85°C		-10		10	nA
			-40°C to +125°C		-45		45	nA
LOGIC INPUTS (SEL / EN pins)								
V_{IH}	Logic voltage high		-40°C to +125°C	1.3		44	V	
V_{IL}	Logic voltage low		-40°C to +125°C	0		0.8	V	
I_{IH}	Input leakage current		-40°C to +125°C		0.005	2	μA	
I_{IL}	Input leakage current		-40°C to +125°C	-1	-0.005		μA	
C_{IN}	Logic input capacitance		-40°C to +125°C		3		pF	
POWER SUPPLY								
I_{DD}	V_{DD} supply current	$V_{DD} = 44\text{ V}$, $V_{SS} = 0\text{ V}$ Logic inputs = 0 V, 5 V, or V_{DD}	25°C		17	50	μA	
			-40°C to +85°C			60	μA	
			-40°C to +125°C			75	μA	

(1) When V_S is 40V, V_D is 1V, or when V_S is 1V, V_D is 40V.

(2) When V_S is at a voltage potential, V_D is floating, or when V_D is at a voltage potential, V_S is floating.

5.11 44 V Single Supply: Switching Characteristics

$V_{DD} = +44\text{ V}$, $V_{SS} = 0\text{ V}$, $GND = 0\text{ V}$ (unless otherwise noted)
 Typical at $V_{DD} = +44\text{ V}$, $V_{SS} = 0\text{ V}$, $T_A = 25^\circ\text{C}$ (unless otherwise noted)

PARAMETER		TEST CONDITIONS	T_A	MIN	TYP	MAX	UNIT
t_{TRAN}	Transition time from control input	$V_S = 18\text{ V}$ $R_L = 300\ \Omega$, $C_L = 35\text{ pF}$ Refer to Transition Time	25°C		120	175	ns
			-40°C to +85°C			190	ns
			-40°C to +125°C			205	ns
$t_{\text{ON (EN)}}$	Turn-on time from enable	$V_S = 18\text{ V}$ $R_L = 300\ \Omega$, $C_L = 35\text{ pF}$ Refer to Turn-on and Turn-off Time	25°C		120	168	ns
			-40°C to +85°C			185	ns
			-40°C to +125°C			195	ns
$t_{\text{OFF (EN)}}$	Turn-off time from enable	$V_S = 18\text{ V}$ $R_L = 300\ \Omega$, $C_L = 35\text{ pF}$ Refer to Turn-on and Turn-off Time	25°C		120	180	ns
			-40°C to +85°C			200	ns
			-40°C to +125°C			205	ns
t_{BBM}	Break-before-make time delay	$V_S = 18\text{ V}$, $R_L = 300\ \Omega$, $C_L = 35\text{ pF}$ Refer to Break-Before-Make	25°C		45		ns
			-40°C to +85°C	1			ns
			-40°C to +125°C	1			ns
$T_{\text{ON (VDD)}}$	Device turn on time (V_{DD} to output)	V_{DD} rise time = 1 μs $R_L = 300\ \Omega$, $C_L = 35\text{ pF}$ Refer to Turn-on (VDD) Time	25°C		0.15		ms
			-40°C to +85°C			0.17	ms
			-40°C to +125°C			0.17	ms
t_{PD}	Propagation delay	$R_L = 50\ \Omega$, $C_L = 5\text{ pF}$ Refer to Propagation Delay	25°C		930		ps
Q_{INJ}	Charge injection	$V_D = 22\text{ V}$, $C_L = 1\text{ nF}$ Refer to Charge Injection	25°C		-16		pC
O_{ISO}	Off-isolation	$R_L = 50\ \Omega$, $C_L = 5\text{ pF}$ $V_S = 6\text{ V}$, $f = 100\text{ kHz}$ Refer to Off Isolation	25°C		-75		dB
O_{ISO}	Off-isolation	$R_L = 50\ \Omega$, $C_L = 5\text{ pF}$ $V_S = 6\text{ V}$, $f = 1\text{ MHz}$ Refer to Off Isolation	25°C		-55		dB
X_{TALK}	Crosstalk	$R_L = 50\ \Omega$, $C_L = 5\text{ pF}$ $V_S = 6\text{ V}$, $f = 100\text{ kHz}$ Refer to Crosstalk	25°C		-117		dB
X_{TALK}	Crosstalk	$R_L = 50\ \Omega$, $C_L = 5\text{ pF}$ $V_S = 6\text{ V}$, $f = 1\text{ MHz}$ Refer to Crosstalk	25°C		-106		dB
BW	-3dB Bandwidth	$R_L = 50\ \Omega$, $C_L = 5\text{ pF}$ $V_S = 6\text{ V}$ Refer to Bandwidth	25°C		37		MHz
I_L	Insertion loss	$R_L = 50\ \Omega$, $C_L = 5\text{ pF}$ $V_S = 6\text{ V}$, $f = 1\text{ MHz}$	25°C		-0.18		dB
ACPSRR	AC Power Supply Rejection Ratio	$V_{\text{PP}} = 0.62\text{ V}$ on V_{DD} and V_{SS} $R_L = 50\ \Omega$, $C_L = 5\text{ pF}$, $f = 1\text{ MHz}$ Refer to ACPSRR	25°C		-60		dB
THD+N	Total Harmonic Distortion + Noise	$V_{\text{PP}} = 22\text{ V}$, $V_{\text{BIAS}} = 22\text{ V}$ $R_L = 10\text{ k}\Omega$, $C_L = 5\text{ pF}$, $f = 20\text{ Hz}$ to 20 kHz Refer to THD + Noise	25°C		0.0004		%
$C_{\text{S(OFF)}}$	Source off capacitance	$V_S = 6\text{ V}$, $f = 1\text{ MHz}$	25°C		34		pF
$C_{\text{D(OFF)}}$	Drain off capacitance	$V_S = 6\text{ V}$, $f = 1\text{ MHz}$	25°C		48		pF
$C_{\text{S(ON)}}$, $C_{\text{D(ON)}}$	On capacitance	$V_S = 6\text{ V}$, $f = 1\text{ MHz}$	25°C		146		pF

5.12 12 V Single Supply: Electrical Characteristics

$V_{DD} = +12\text{ V} \pm 10\%$, $V_{SS} = 0\text{ V}$, $GND = 0\text{ V}$ (unless otherwise noted)

Typical at $V_{DD} = +12\text{ V}$, $V_{SS} = 0\text{ V}$, $T_A = 25^\circ\text{C}$ (unless otherwise noted)

PARAMETER		TEST CONDITIONS	T_A	MIN	TYP	MAX	UNIT	
ANALOG SWITCH								
R_{ON}	On-resistance	$V_S = 0\text{ V to }10\text{ V}$ $I_D = -10\text{ mA}$ Refer to On-Resistance	25°C	4.6	6		Ω	
			-40°C to +85°C			7.5	Ω	
			-40°C to +125°C			8.4	Ω	
ΔR_{ON}	On-resistance mismatch between channels	$V_S = 0\text{ V to }10\text{ V}$ $I_D = -10\text{ mA}$ Refer to On-Resistance	25°C	0.08	0.2		Ω	
			-40°C to +85°C			0.32	Ω	
			-40°C to +125°C			0.35	Ω	
$R_{ON\ FLAT}$	On-resistance flatness	$V_S = 0\text{ V to }10\text{ V}$ $I_S = -10\text{ mA}$ Refer to On-Resistance	25°C	1.2	2		Ω	
			-40°C to +85°C			2.2	Ω	
			-40°C to +125°C			2.4	Ω	
$R_{ON\ DRIFT}$	On-resistance drift	$V_S = 6\text{ V}$, $I_S = -10\text{ mA}$ Refer to On-Resistance	-40°C to +125°C	0.017			$\Omega/^\circ\text{C}$	
$I_{S(OFF)}$	Source off leakage current ⁽¹⁾	$V_{DD} = 13.2\text{ V}$, $V_{SS} = 0\text{ V}$ Switch state is off $V_S = 10\text{ V} / 1\text{ V}$ $V_D = 1\text{ V} / 10\text{ V}$ Refer to Off-Leakage Current	25°C	-0.5	0.05	0.5	nA	
			-40°C to +85°C		-2		2	nA
			-40°C to +125°C		-12		12	nA
$I_{D(OFF)}$	Drain off leakage current ⁽¹⁾	$V_{DD} = 13.2\text{ V}$, $V_{SS} = 0\text{ V}$ Switch state is off $V_S = 10\text{ V} / 1\text{ V}$ $V_D = 1\text{ V} / 10\text{ V}$ Refer to Off-Leakage Current	25°C	-0.5	0.05	0.5	nA	
			-40°C to +85°C		-3		3	nA
			-40°C to +125°C		-23		23	nA
$I_{S(ON)}$ $I_{D(ON)}$	Channel on leakage current ⁽²⁾	$V_{DD} = 13.2\text{ V}$, $V_{SS} = 0\text{ V}$ Switch state is on $V_S = V_D = 10\text{ V}$ or 1 V Refer to On-Leakage Current	25°C	-1.5	0.05	1.5	nA	
			-40°C to +85°C		-3		3	nA
			-40°C to +125°C		-15		15	nA
LOGIC INPUTS (SEL / EN pins)								
V_{IH}	Logic voltage high		-40°C to +125°C	1.3		44	V	
V_{IL}	Logic voltage low		-40°C to +125°C	0		0.8	V	
I_{IH}	Input leakage current		-40°C to +125°C		0.005	1	μA	
I_{IL}	Input leakage current		-40°C to +125°C	-1	-0.005		μA	
C_{IN}	Logic input capacitance		-40°C to +125°C		3		pF	
POWER SUPPLY								
I_{DD}	V_{DD} supply current	$V_{DD} = 13.2\text{ V}$, $V_{SS} = 0\text{ V}$ Logic inputs = 0 V, 5 V, or V_{DD}	25°C	10	35		μA	
			-40°C to +85°C			45	μA	
			-40°C to +125°C			55	μA	

(1) When V_S is 10V, V_D is 1V, or when V_S is 1V, V_D is 10V.

(2) When V_S is at a voltage potential, V_D is floating, or when V_D is at a voltage potential, V_S is floating.

5.13 12 V Single Supply: Switching Characteristics

$V_{DD} = +12\text{ V} \pm 10\%$, $V_{SS} = 0\text{ V}$, $GND = 0\text{ V}$ (unless otherwise noted)
 Typical at $V_{DD} = +12\text{ V}$, $V_{SS} = 0\text{ V}$, $T_A = 25^\circ\text{C}$ (unless otherwise noted)

PARAMETER		TEST CONDITIONS	T_A	MIN	TYP	MAX	UNIT
t_{TRAN}	Transition time from control input	$V_S = 8\text{ V}$ $R_L = 300\ \Omega$, $C_L = 35\text{ pF}$ Refer to Transition Time	25°C		180	185	ns
			-40°C to +85°C			215	ns
			-40°C to +125°C			235	ns
$t_{\text{ON (EN)}}$	Turn-on time from enable	$V_S = 8\text{ V}$ $R_L = 300\ \Omega$, $C_L = 35\text{ pF}$ Refer to Turn-on and Turn-off Time	25°C		120	180	ns
			-40°C to +85°C			210	ns
			-40°C to +125°C			230	ns
$t_{\text{OFF (EN)}}$	Turn-off time from enable	$V_S = 8\text{ V}$ $R_L = 300\ \Omega$, $C_L = 35\text{ pF}$ Refer to Turn-on and Turn-off Time	25°C		130	210	ns
			-40°C to +85°C			235	ns
			-40°C to +125°C			250	ns
t_{BBM}	Break-before-make time delay	$V_S = 8\text{ V}$, $R_L = 300\ \Omega$, $C_L = 35\text{ pF}$ Refer to Break-Before-Make	25°C		40		ns
			-40°C to +85°C	1			ns
			-40°C to +125°C	1			ns
$T_{\text{ON (VDD)}}$	Device turn on time (V_{DD} to output)	V_{DD} rise time = 100ns $R_L = 300\ \Omega$, $C_L = 35\text{ pF}$ Refer to Turn-on (VDD) Time	25°C		0.19		ms
			-40°C to +85°C			0.2	ms
			-40°C to +125°C			0.2	ms
t_{PD}	Propagation delay	$R_L = 50\ \Omega$, $C_L = 5\text{ pF}$ Refer to Propagation Delay	25°C		740		ps
Q_{INJ}	Charge injection	$V_D = 6\text{ V}$, $C_L = 1\text{ nF}$ Refer to Charge Injection	25°C		-6		pC
O_{ISO}	Off-isolation	$R_L = 50\ \Omega$, $C_L = 5\text{ pF}$ $V_S = 6\text{ V}$, $f = 100\text{ kHz}$ Refer to Off Isolation	25°C		-75		dB
O_{ISO}	Off-isolation	$R_L = 50\ \Omega$, $C_L = 5\text{ pF}$ $V_S = 6\text{ V}$, $f = 1\text{ MHz}$ Refer to Off Isolation	25°C		-55		dB
X_{TALK}	Crosstalk	$R_L = 50\ \Omega$, $C_L = 5\text{ pF}$ $V_S = 6\text{ V}$, $f = 100\text{ kHz}$ Refer to Crosstalk	25°C		-117		dB
X_{TALK}	Crosstalk	$R_L = 50\ \Omega$, $C_L = 5\text{ pF}$ $V_S = 6\text{ V}$, $f = 1\text{ MHz}$ Refer to Crosstalk	25°C		-106		dB
BW	-3dB Bandwidth	$R_L = 50\ \Omega$, $C_L = 5\text{ pF}$ $V_S = 6\text{ V}$ Refer to Bandwidth	25°C		42		MHz
I_L	Insertion loss	$R_L = 50\ \Omega$, $C_L = 5\text{ pF}$ $V_S = 6\text{ V}$, $f = 1\text{ MHz}$	25°C		-0.3		dB
ACPSRR	AC Power Supply Rejection Ratio	$V_{\text{PP}} = 0.62\text{ V}$ on V_{DD} and V_{SS} $R_L = 50\ \Omega$, $C_L = 5\text{ pF}$, $f = 1\text{ MHz}$ Refer to ACPSRR	25°C		-65		dB
THD+N	Total Harmonic Distortion + Noise	$V_{\text{PP}} = 6\text{ V}$, $V_{\text{BIAS}} = 6\text{ V}$ $R_L = 10\text{ k}\Omega$, $C_L = 5\text{ pF}$, $f = 20\text{ Hz}$ to 20 kHz Refer to THD + Noise	25°C		0.0009		%
$C_{\text{S(OFF)}}$	Source off capacitance	$V_S = 6\text{ V}$, $f = 1\text{ MHz}$	25°C		38		pF
$C_{\text{D(OFF)}}$	Drain off capacitance	$V_S = 6\text{ V}$, $f = 1\text{ MHz}$	25°C		56		pF
$C_{\text{S(ON)}}$, $C_{\text{D(ON)}}$	On capacitance	$V_S = 6\text{ V}$, $f = 1\text{ MHz}$	25°C		150		pF

5.14 Typical Characteristics

at $T_A = 25^\circ\text{C}$

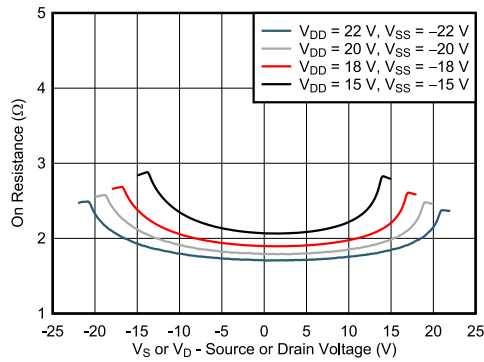

Figure 5-1. On-Resistance vs Source or Drain Voltage – Dual Supply

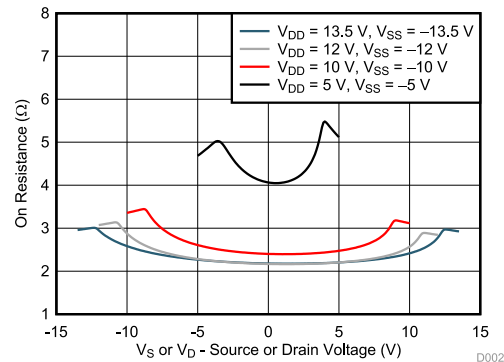

Figure 5-2. On-Resistance vs Source or Drain Voltage – Dual Supply

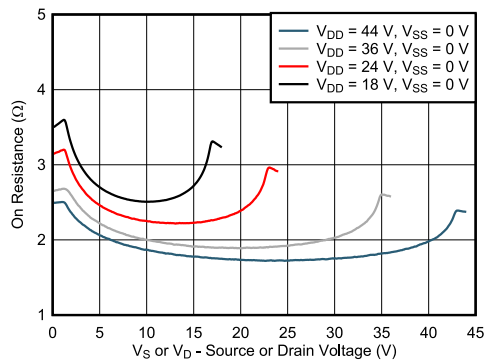

Figure 5-3. On-Resistance vs Source or Drain Voltage – Single Supply

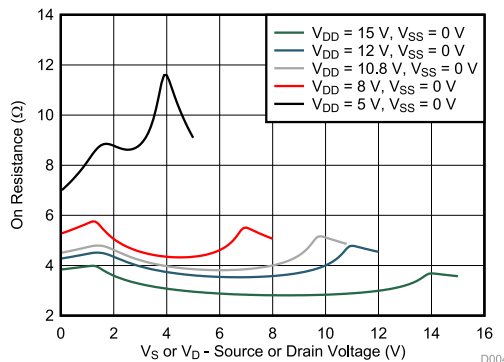

Figure 5-4. On-Resistance vs Source or Drain Voltage – Single Supply

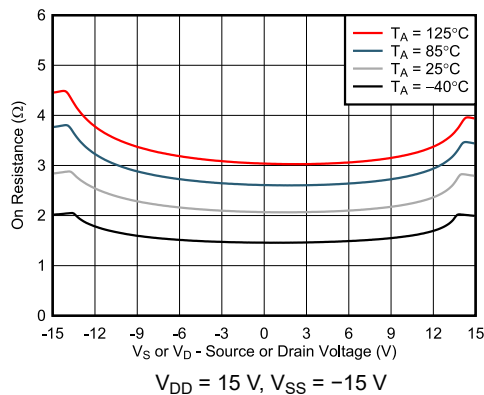

Figure 5-5. On-Resistance vs Temperature

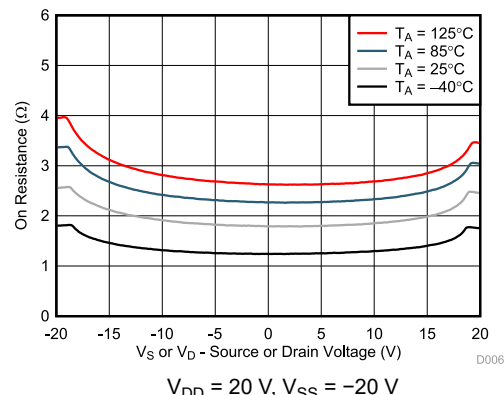

Figure 5-6. On-Resistance vs Temperature

5.14 Typical Characteristics (continued)

at $T_A = 25^\circ\text{C}$

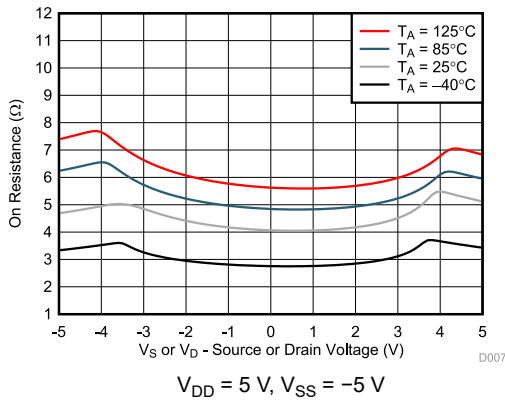

Figure 5-7. On-Resistance vs Temperature

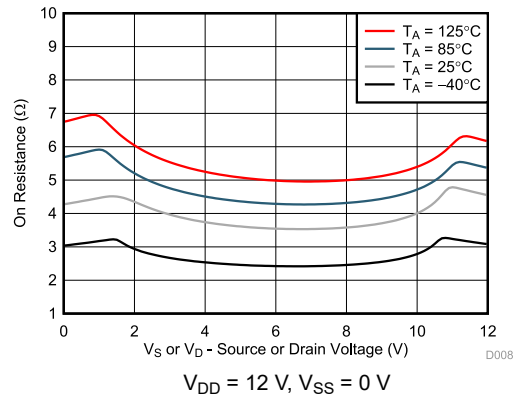

Figure 5-8. On-Resistance vs Temperature

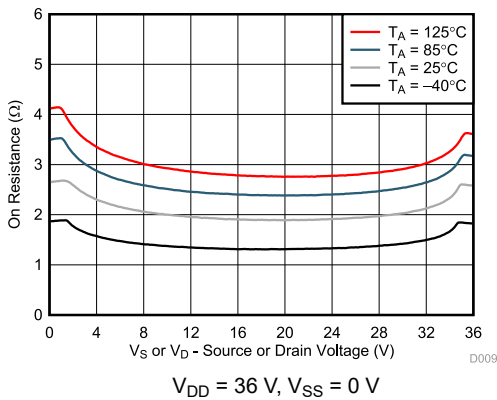

Figure 5-9. On-Resistance vs Temperature

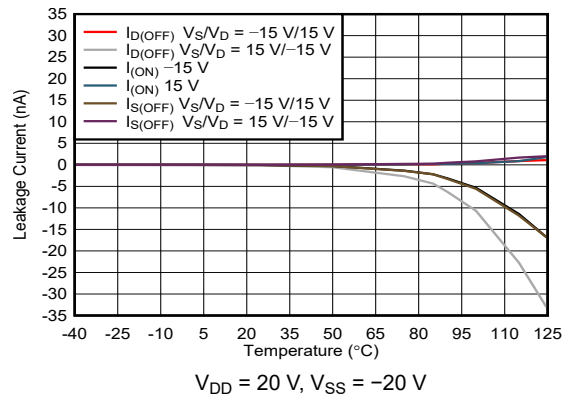

Figure 5-10. Leakage Current vs Temperature

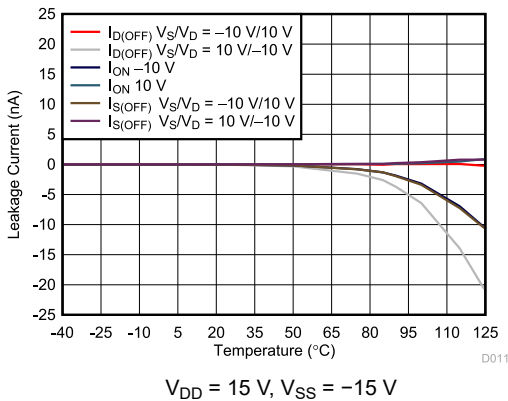

Figure 5-11. Leakage Current vs Temperature

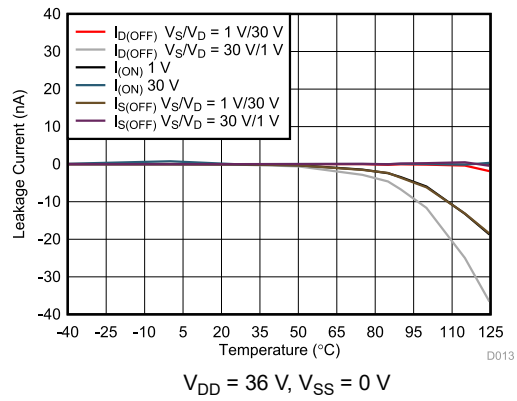
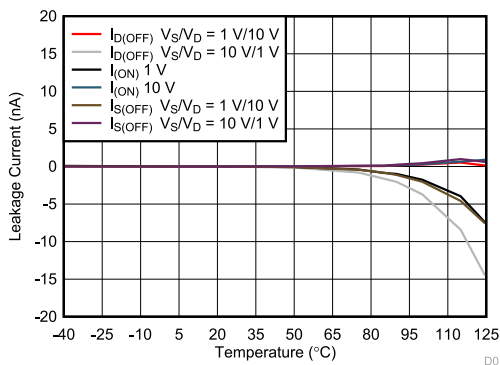

Figure 5-12. Leakage Current vs Temperature

5.14 Typical Characteristics (continued)

at $T_A = 25^\circ\text{C}$



$V_{DD} = 12\text{ V}, V_{SS} = 0\text{ V}$

Figure 5-13. Leakage Current vs Temperature

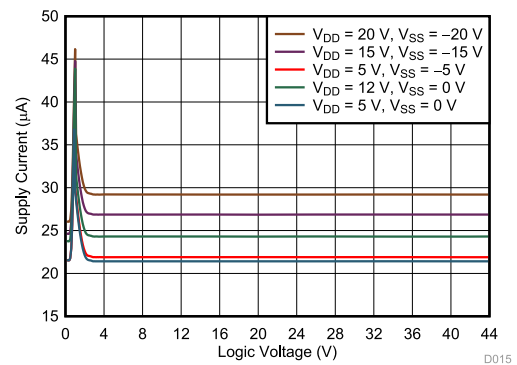

Figure 5-14. Supply Current vs Logic Voltage

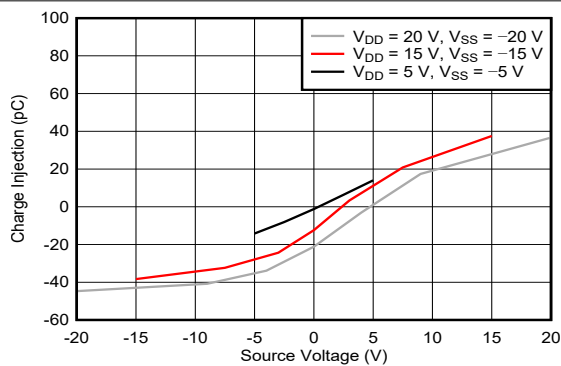

Figure 5-15. Charge Injection vs Source Voltage – Dual Supply

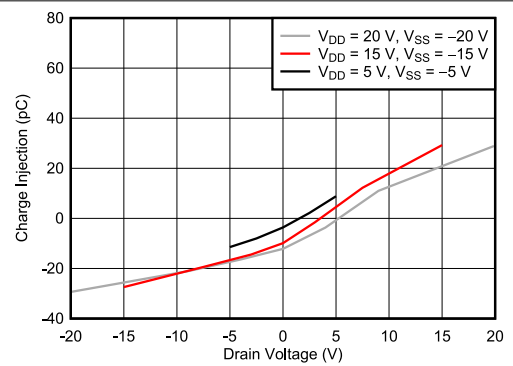

Figure 5-16. Charge Injection vs Drain Voltage – Dual Supply

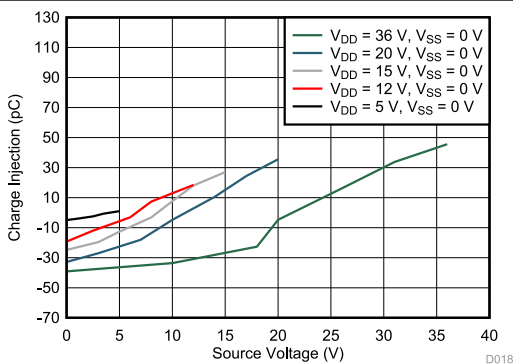

Figure 5-17. Charge Injection vs Source Voltage – Single Supply

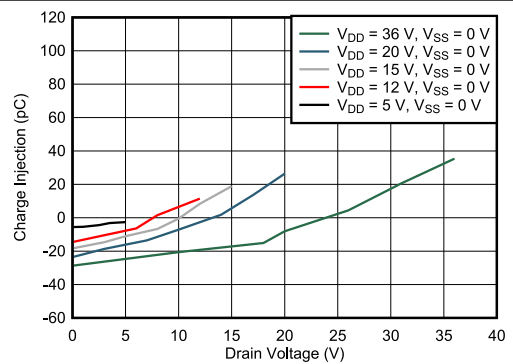
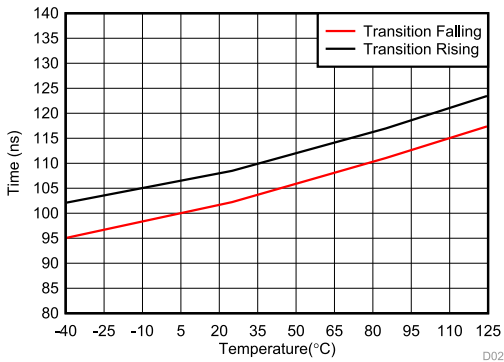

Figure 5-18. Charge Injection vs Drain Voltage – Single Supply

5.14 Typical Characteristics (continued)

at $T_A = 25^\circ\text{C}$



$V_{DD} = 15\text{ V}, V_{SS} = -15\text{ V}$

Figure 5-19. $T_{\text{TRANSITION}}$ vs Temperature

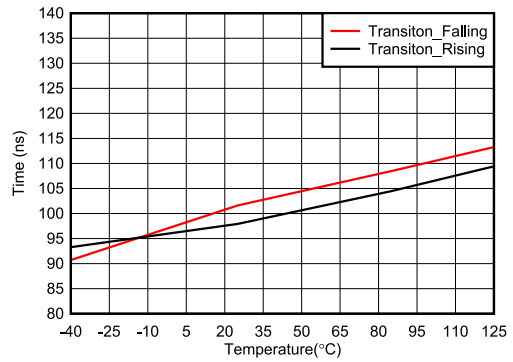

$V_{DD} = 44\text{ V}, V_{SS} = 0\text{ V}$

Figure 5-20. $T_{\text{TRANSITION}}$ vs Temperature

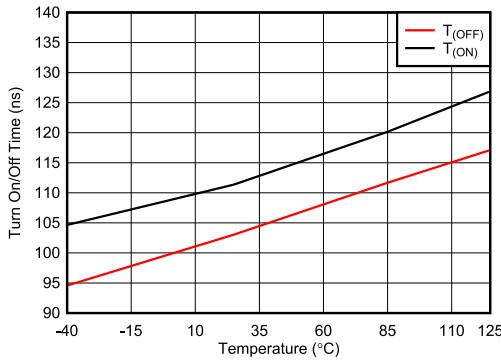

$V_{DD} = 15\text{ V}, V_{SS} = -15\text{ V}$

Figure 5-21. T_{ON} and T_{OFF} vs Temperature

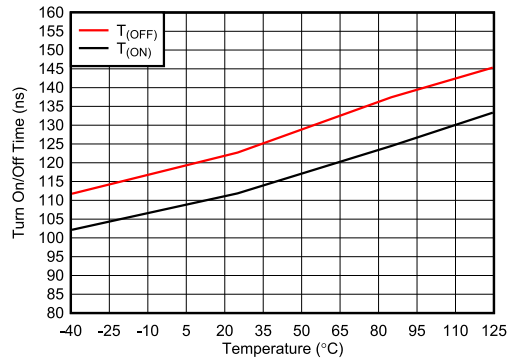

$V_{DD} = 44\text{ V}, V_{SS} = 0\text{ V}$

Figure 5-22. T_{ON} and T_{OFF} vs Temperature

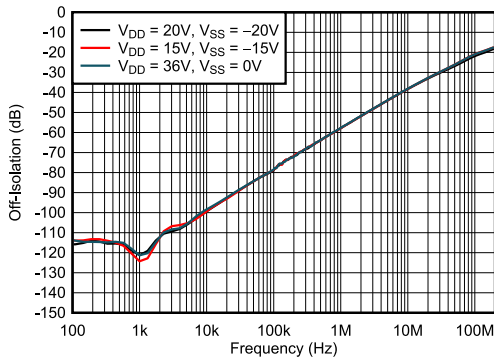
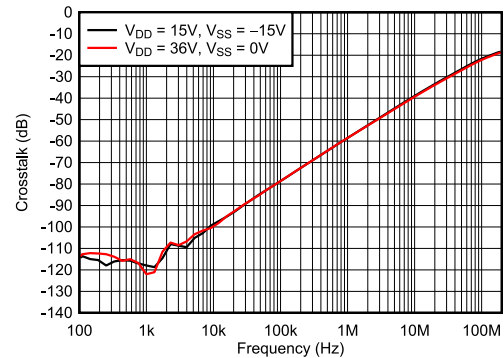

Figure 5-23. Off-Isolation vs Frequency



Switch ON (EN = 1)

Figure 5-24. Crosstalk vs Frequency

5.14 Typical Characteristics (continued)

at $T_A = 25^\circ\text{C}$

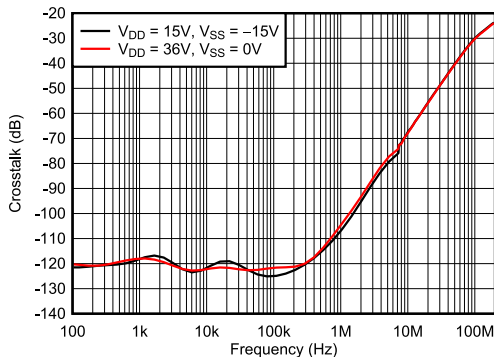

Switch OFF (EN = 0)

Figure 5-25. Crosstalk vs Frequency

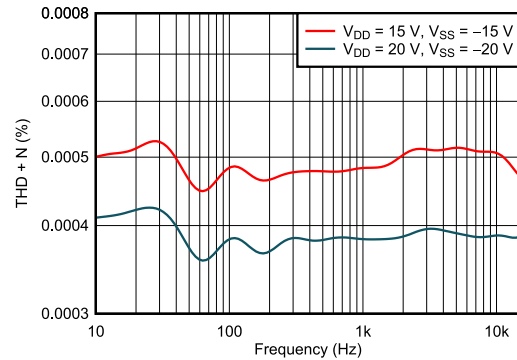

Figure 5-26. THD+N vs Frequency (Dual Supply)

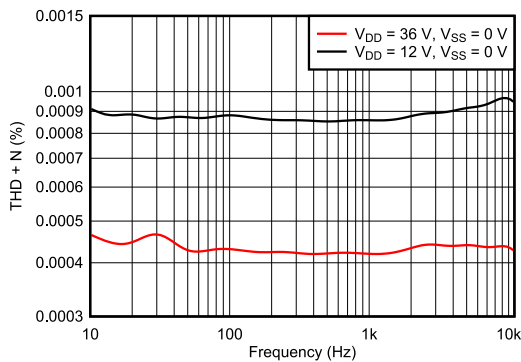
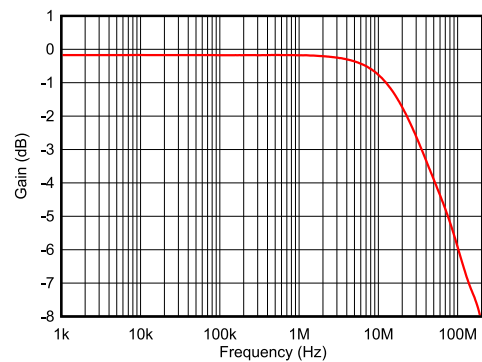
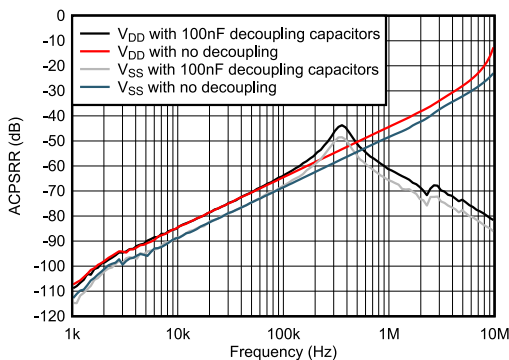

Figure 5-27. THD+N vs Frequency (Single Supply)



$V_{DD} = 15\text{ V}, V_{SS} = -15\text{ V}$

Figure 5-28. On Response vs Frequency



$V_{DD} = +15\text{ V}, V_{SS} = -15\text{ V}$

Figure 5-29. ACPSRR vs Frequency

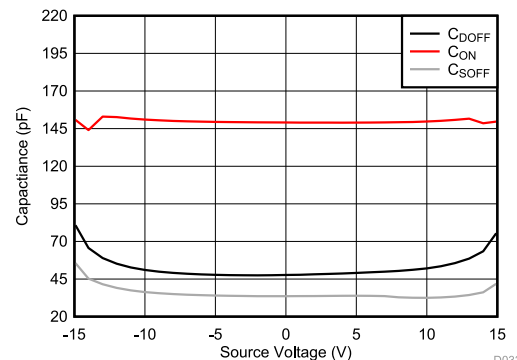

$V_{DD} = +15\text{ V}, V_{SS} = -15\text{ V}$

Figure 5-30. Capacitance vs Source Voltage or Drain Voltage

5.14 Typical Characteristics (continued)

at $T_A = 25^\circ\text{C}$

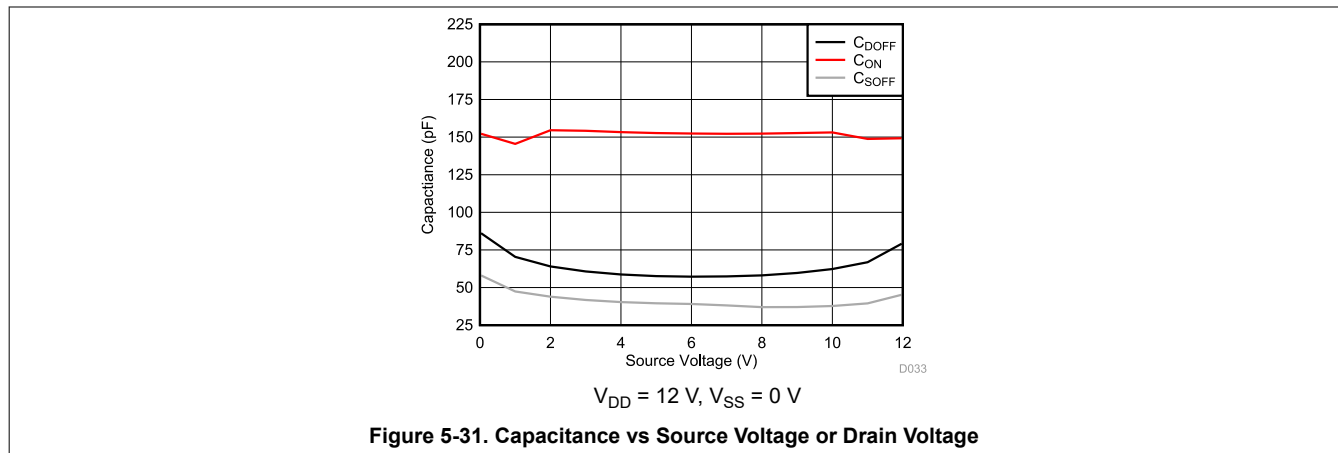

6 Parameter Measurement Information

6.1 On-Resistance

The on-resistance of a device is the ohmic resistance between the source (Sx) and drain (D) pins of the device. The on-resistance varies with input voltage and supply voltage. The symbol R_{ON} is used to denote on-resistance. Figure 6-1 shows the measurement setup used to measure R_{ON} . Voltage (V) and current (I_{SD}) are measured using the following setup, where R_{ON} is computed as $R_{ON} = V / I_{SD}$:

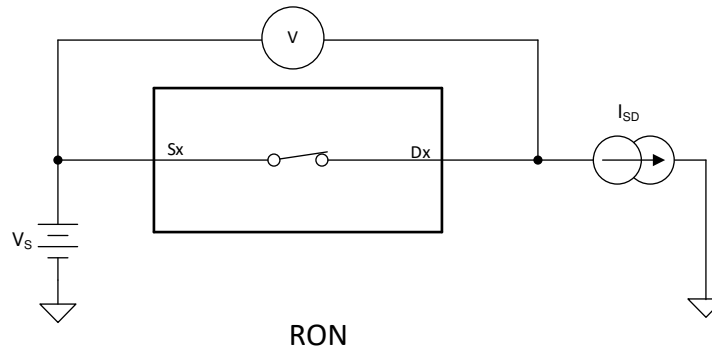

Figure 6-1. On-Resistance

6.2 Off-Leakage Current

There are two types of leakage currents associated with a switch during the off state:

1. Source off-leakage current.
2. Drain off-leakage current.

Source leakage current is defined as the leakage current flowing into or out of the source pin when the switch is off. This current is denoted by the symbol $I_{S(OFF)}$.

Drain leakage current is defined as the leakage current flowing into or out of the drain pin when the switch is off. This current is denoted by the symbol $I_{D(OFF)}$.

Figure 6-2 shows the setup used to measure both off-leakage currents.

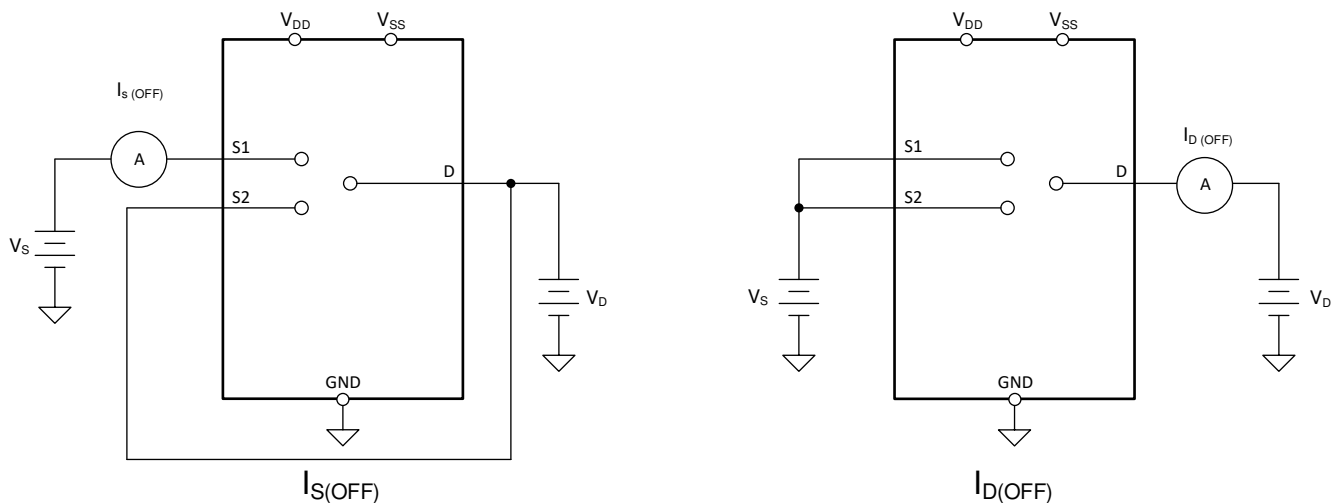

Figure 6-2. Off-Leakage Measurement Setup

6.3 On-Leakage Current

Source on-leakage current is defined as the leakage current flowing into or out of the source pin when the switch is on. This current is denoted by the symbol $I_{S(ON)}$.

Drain on-leakage current is defined as the leakage current flowing into or out of the drain pin when the switch is on. This current is denoted by the symbol $I_{D(ON)}$.

Either the source pin or drain pin is left floating during the measurement. Figure 6-3 shows the circuit used for measuring the on-leakage current, denoted by $I_{S(ON)}$ or $I_{D(ON)}$.

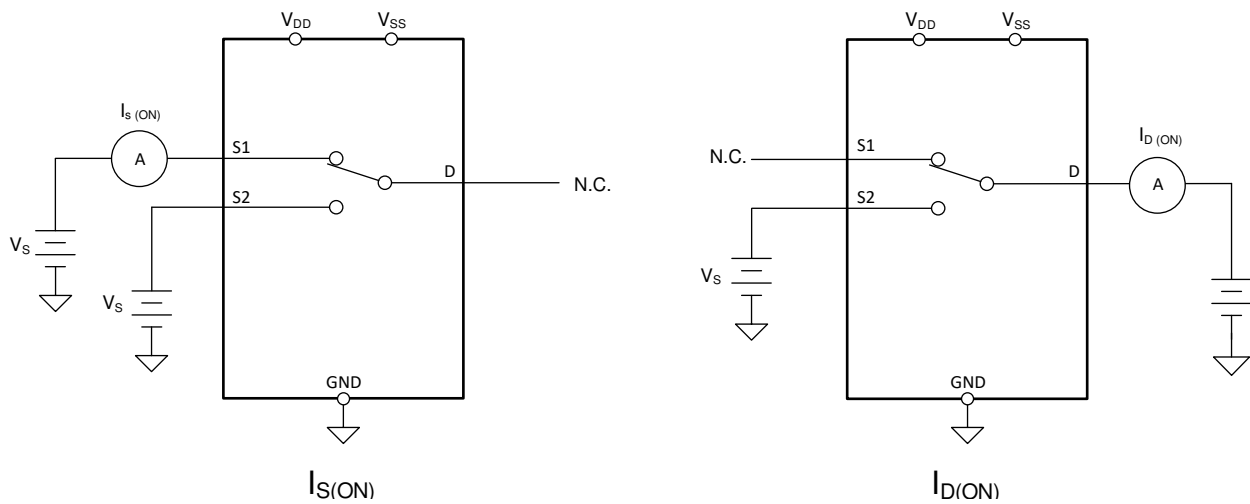

Figure 6-3. On-Leakage Measurement Setup

6.4 Transition Time

Transition time is defined as the time taken by the output of the device to rise or fall 90% after the address signal has risen or fallen past the logic threshold. The 90% transition measurement is utilized to provide the timing of the device. System level timing can then account for the time constant added from the load resistance and load capacitance. Figure 6-4 shows the setup used to measure transition time, denoted by the symbol $t_{TRANSITION}$.

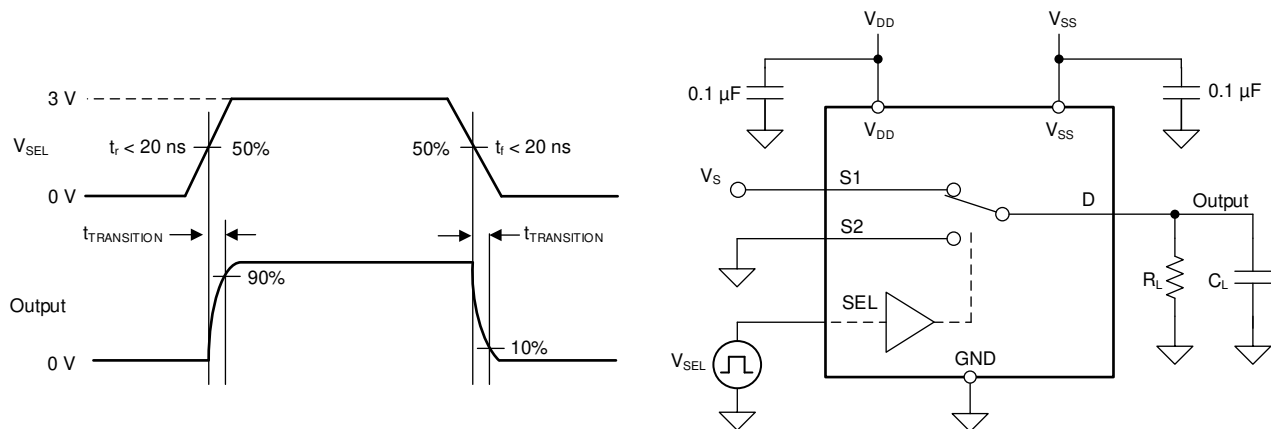

Figure 6-4. Transition-Time Measurement Setup

6.5 $t_{ON(EN)}$ and $t_{OFF(EN)}$

Turn-on time is defined as the time taken by the output of the device to rise to 90% after the enable has risen past the logic threshold. The 90% measurement is utilized to provide the timing of the device. System level timing can then account for the time constant added from the load resistance and load capacitance. Figure 6-5 shows the setup used to measure turn-on time, denoted by the symbol $t_{ON(EN)}$.

Turn-off time is defined as the time taken by the output of the device to fall to 10% after the enable has fallen past the logic threshold. The 10% measurement is utilized to provide the timing of the device. System level timing can then account for the time constant added from the load resistance and load capacitance. Figure 6-5 shows the setup used to measure turn-off time, denoted by the symbol $t_{OFF(EN)}$.

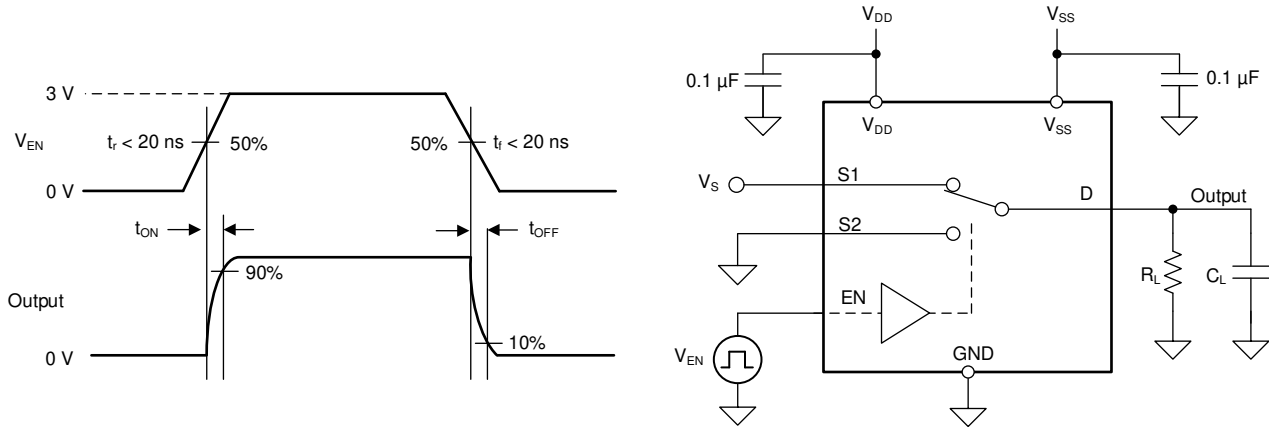

Figure 6-5. Turn-On and Turn-Off Time Measurement Setup

6.6 Break-Before-Make

Break-before-make delay is a safety feature that prevents two inputs from connecting when the device is switching. The output first breaks from the on-state switch before making the connection with the next on-state switch. The time delay between the *break* and the *make* is known as break-before-make delay. Figure 6-6 shows the setup used to measure break-before-make delay, denoted by the symbol $t_{OPEN(BBM)}$.

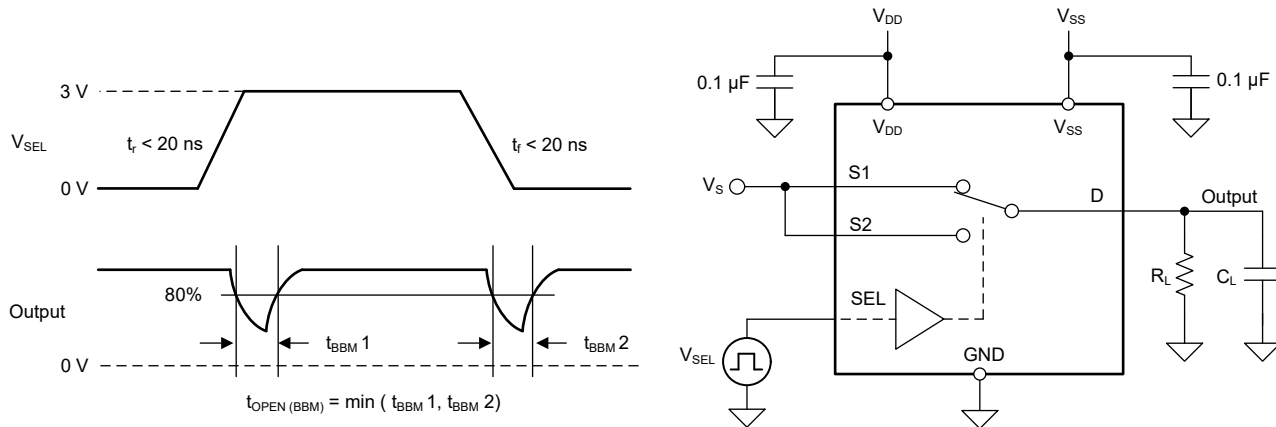

Figure 6-6. Break-Before-Make Delay Measurement Setup

6.7 $t_{ON(VDD)}$ Time

The $t_{ON(VDD)}$ time is defined as the time taken by the output of the device to rise to 90% after the supply has risen past the supply threshold. The 90% measurement is used to provide the timing of the device turning on in the system. Figure 6-7 shows the setup used to measure turn on time, denoted by the symbol $t_{ON(VDD)}$.

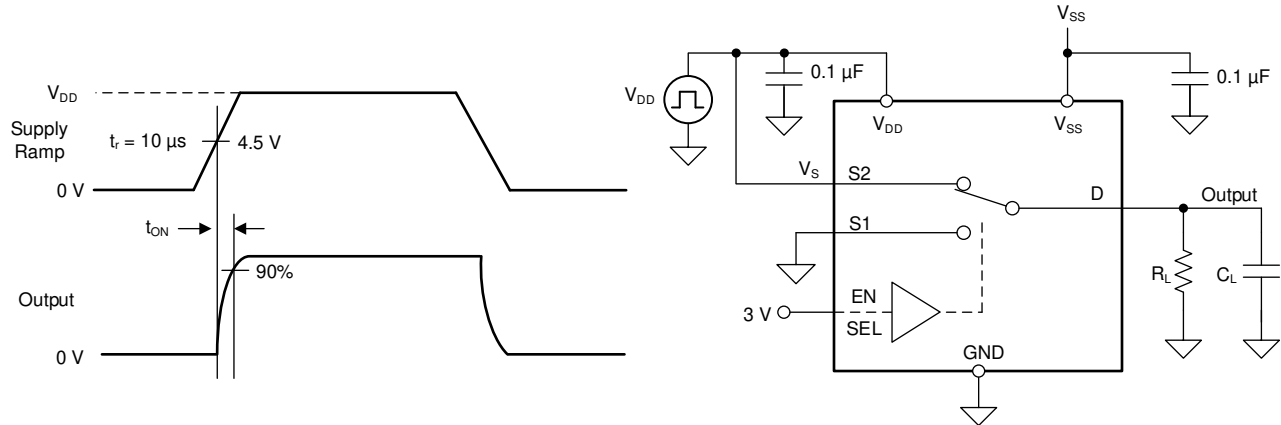

Figure 6-7. $t_{ON(VDD)}$ Time Measurement Setup

6.8 Propagation Delay

Propagation delay is defined as the time taken by the output of the device to rise or fall 50% after the input signal has risen or fallen past the 50% threshold. Figure 6-8 shows the setup used to measure propagation delay, denoted by the symbol t_{PD} .

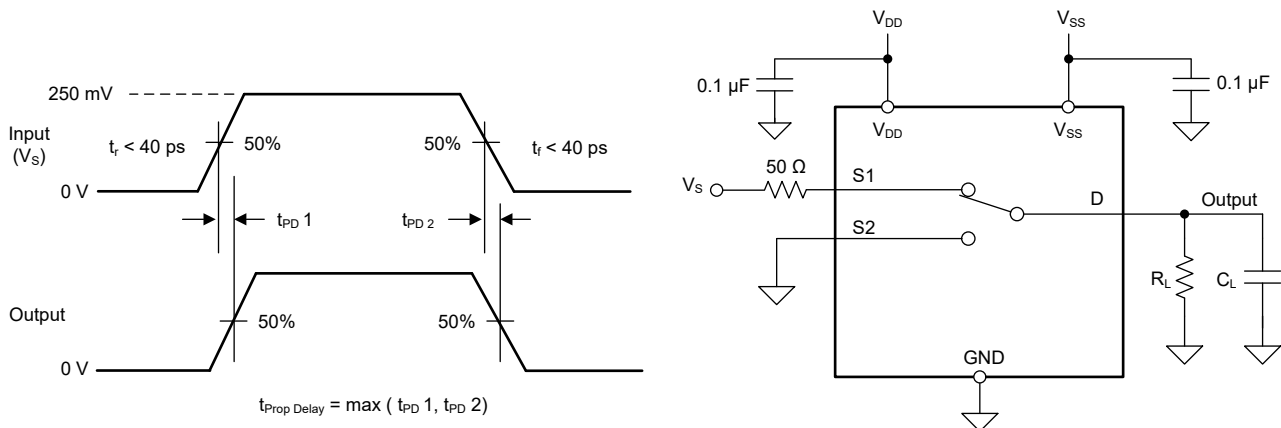

Figure 6-8. Propagation Delay Measurement Setup

6.9 Charge Injection

The TMUX7219 has a transmission-gate topology. Any mismatch in capacitance between the NMOS and PMOS transistors results in a charge injected into the drain or source during the falling or rising edge of the gate signal. The amount of charge injected into the source or drain of the device is known as charge injection, and is denoted by the symbol Q_C . Figure 6-9 shows the setup used to measure charge injection from source (Sx) to drain (D).

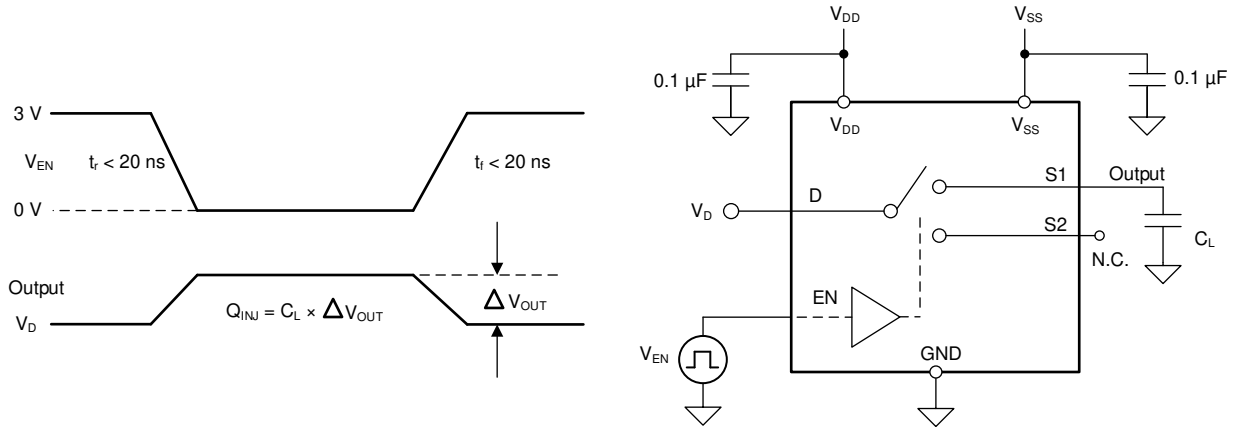
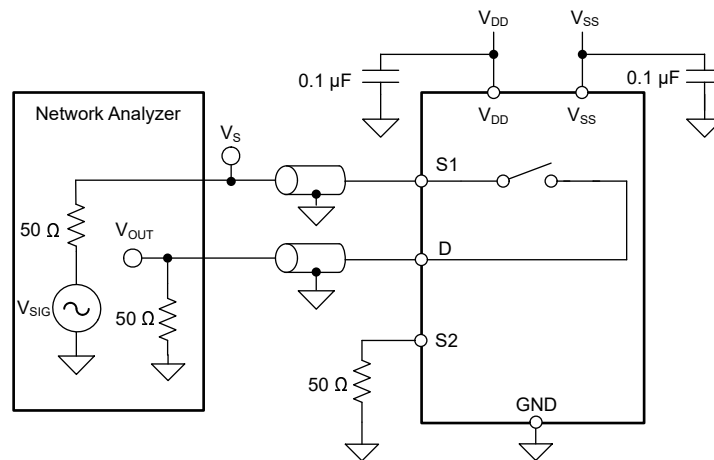

Figure 6-9. Charge-Injection Measurement Setup

6.10 Off Isolation

Off isolation is defined as the ratio of the signal at the drain pin (D) of the device when a signal is applied to the source pin (Sx) of an off-channel. Figure 6-10 shows the setup used to measure, and the equation used to calculate off isolation.



$$\text{Off Isolation} = 20 \times \text{Log} \frac{V_{\text{OUT}}}{V_{\text{S}}}$$

Figure 6-10. Off Isolation Measurement Setup

6.11 Crosstalk

Crosstalk is defined as the ratio of the signal at the drain pin (D) of a different channel, when a signal is applied at the source pin (Sx) of an on-channel. [Figure 6-11](#) shows the setup used to measure, and the equation used to calculate crosstalk.

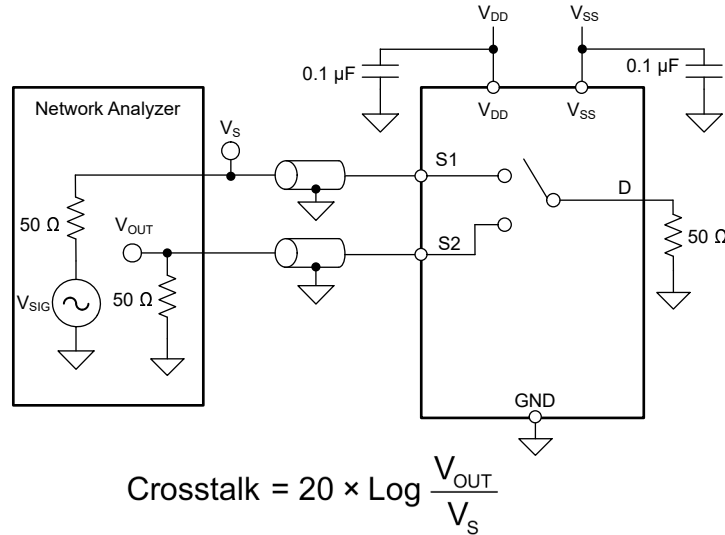

Figure 6-11. Crosstalk Measurement Setup

6.12 Bandwidth

Bandwidth is defined as the range of frequencies that are attenuated by less than 3 dB when the input is applied to the source pin (Sx) of an on-channel, and the output is measured at the drain pin (D) of the device. [Figure 6-12](#) shows the setup used to measure bandwidth.

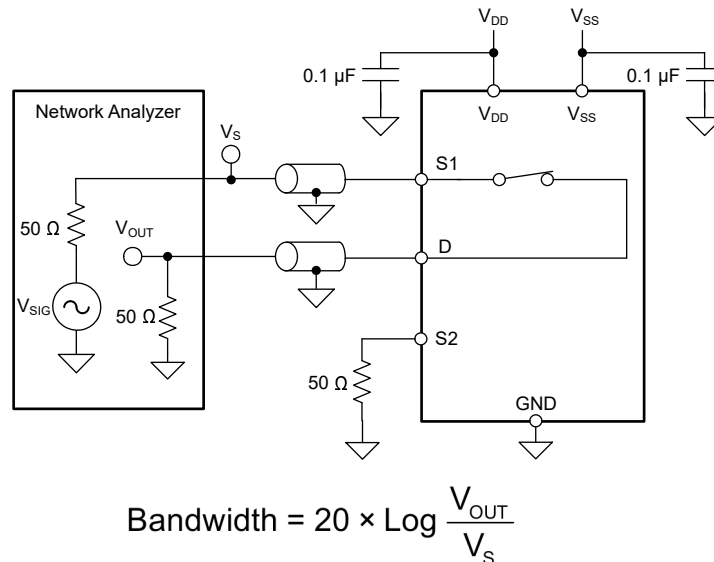

Figure 6-12. Bandwidth Measurement Setup

6.13 THD + Noise

The total harmonic distortion (THD) of a signal is a measurement of the harmonic distortion, and is defined as the ratio of the sum of the powers of all harmonic components to the power of the fundamental frequency at the mux output.

The on-resistance of the device varies with the amplitude of the input signal and results in distortion when the drain pin is connected to a low-impedance load. Total harmonic distortion plus noise is denoted as THD + N.

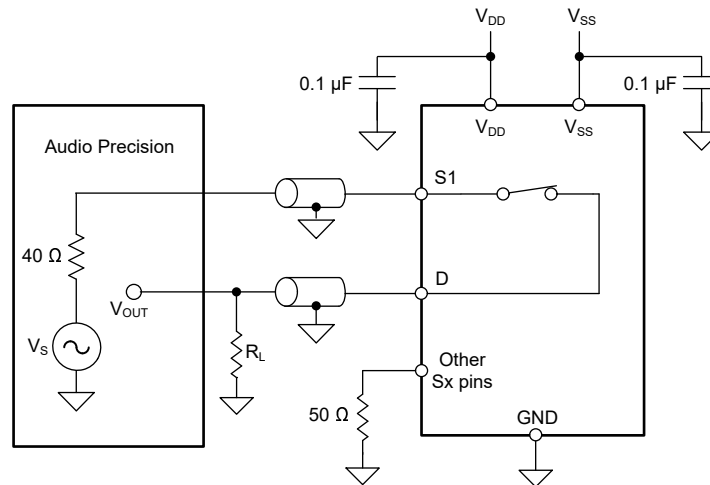
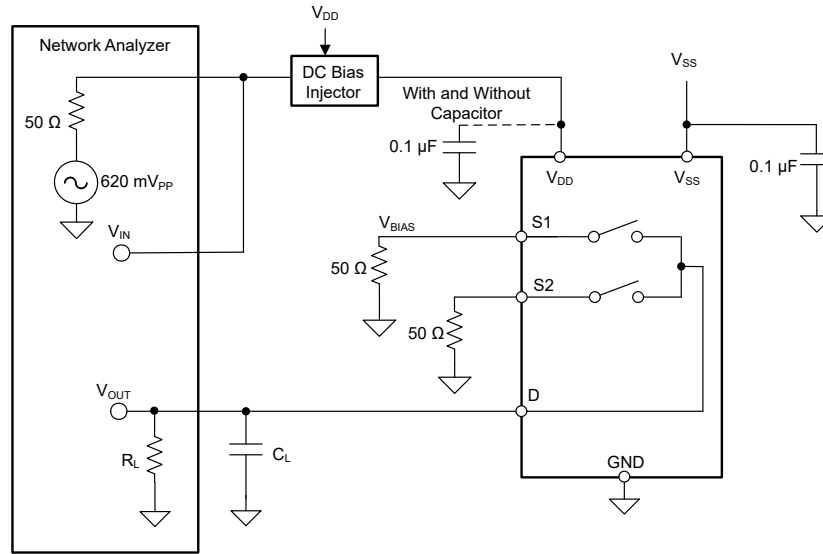

Figure 6-13. THD + N Measurement Setup

6.14 Power Supply Rejection Ratio (PSRR)

PSRR measures the ability of a device to prevent noise and spurious signals that appear on the supply voltage pin from coupling to the output of the switch. The DC voltage on the device supply is modulated by a sine wave of 620 mV_{PP}. The ratio of the amplitude of signal on the output to the amplitude of the modulated signal is the ACPSRR. A high ratio represents a high degree of tolerance to supply rail variation.

This helps stabilize the supply and immediately filter as much of the supply noise as possible.



$$PSRR = 20 \times \text{Log} \frac{V_{OUT}}{V_{IN}}$$

Figure 6-14. ACPSRR Measurement Setup

7 Detailed Description

7.1 Overview

The TMUX7219 is a 2:1, 1-channel switch. Each input is turned on or turned off based on the state of the select line and enable pin.

7.2 Functional Block Diagram

The following figure shows the functional block diagram of the TMUX7219.

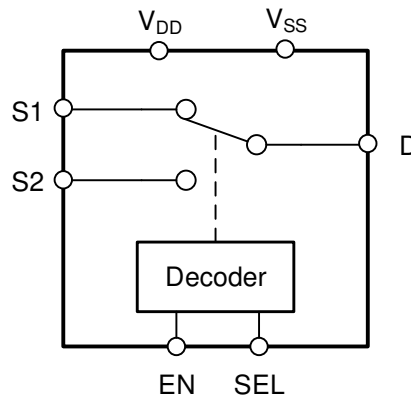

7.3 Feature Description

7.3.1 Bidirectional Operation

The TMUX7219 conducts equally well from source (S_x) to drain (D) or from drain (D) to source (S_x). Each channel has very similar characteristics in both directions and supports both analog and digital signals.

7.3.2 Rail-to-Rail Operation

The valid signal path input and output voltage for TMUX7219 ranges from V_{SS} to V_{DD}.

7.3.3 1.8 V Logic Compatible Inputs

The TMUX7219 has 1.8 V logic compatible control for all logic control inputs. 1.8 V logic level inputs allows the device to interface with processors that have lower logic I/O rails and eliminates the need for an external translator, which saves both space and BOM cost. For more information on 1.8 V logic implementations refer to [Simplifying Design with 1.8 V logic Muxes and Switches](#).

7.3.4 Integrated Pull-Up and Pull-Down Resistor on Logic Pins

The TMUX7219 has internal weak pull-up and pull-down resistors to GND to ensure the logic pins are not left floating. The value of this pull-down resistor is approximately 4 M Ω , but is clamped to about 1 μ A at higher voltages. The EN pin integrates a pull-up resistor to V_{DD} and the SEL pin integrates a pull-down resistor. This feature integrates up to two external components and reduces system size and cost.

7.3.5 Fail-Safe Logic

The TMUX7219 supports Fail-Safe Logic on the control input pins (EN and SEL) allowing for operation up to 44 V above ground, regardless of the state of the supply pins. This feature allows voltages on the control pins to be applied before the supply pin, protecting the device from potential damage. Fail-Safe Logic minimizes system complexity by removing the need for power supply sequencing on the logic control pins. For example, the Fail-Safe Logic feature allows the logic input pins of the TMUX7219 to be ramped to +44 V while V_{DD} and V_{SS} = 0 V. The logic control inputs are protected against positive faults of up to +44 V in powered-off condition, but do not offer protection against negative overvoltage conditions.

7.3.6 Latch-Up Immune

Latch-up is a condition where a low impedance path is created between a supply pin and ground. This condition is caused by a trigger (current injection or overvoltage), but once activated, the low impedance path remains even after the trigger is no longer present. This low impedance path may cause system upset or catastrophic damage due to excessive current levels. The latch-up condition typically requires a power cycle to eliminate the low impedance path.

The TMUX72xx family of devices are constructed on Silicon on Insulator (SOI) based process where an oxide layer is added between the PMOS and NMOS transistor of each CMOS switch to prevent parasitic structures from forming. The oxide layer is also known as an insulating trench and prevents triggering of latch up events due to overvoltage or current injections. The latch-up immunity feature allows the TMUX72xx family of switches and multiplexers to be used in harsh environments. For more information on latch-up immunity refer to [Using Latch Up Immune Multiplexers to Help Improve System Reliability](#).

7.3.7 Ultra-Low Charge Injection

Figure 7-1 shows how the TMUX7219 has a transmission gate topology. Any mismatch in the stray capacitance associated with the NMOS and PMOS causes an output level change whenever the switch is opened or closed.

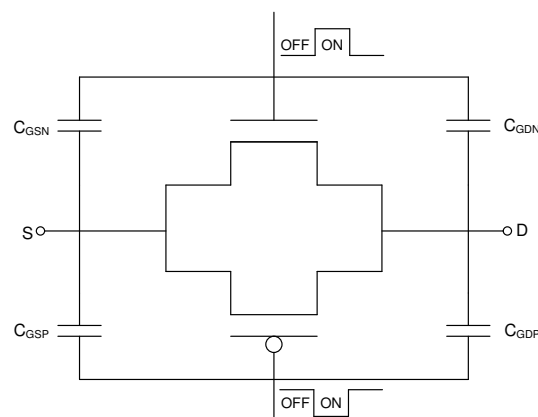

Figure 7-1. Transmission Gate Topology

The TMUX7219 contains specialized architecture to reduce charge injection on the source (Sx). To further reduce charge injection in a sensitive application, a compensation capacitor (Cp) can be added on the drain (D). This will ensure that excess charge from the switch transition will be pushed into the compensation capacitor on the drain (D) instead of the source (Sx). As a general rule, Cp should be 20× larger than the equivalent load capacitance on the source (Sx). Figure 7-2 shows charge injection variation with source voltage with different compensation capacitors on the drain side.

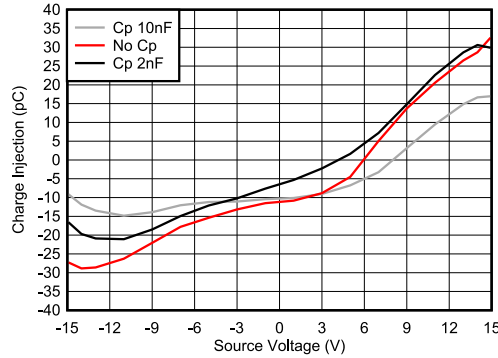

Figure 7-2. Charge Injection Compensation

7.4 Device Functional Modes

When the EN pin of the TMUX7219 is pulled high, one of the switches is closed based on the state of the SEL pin. When the EN pin is pulled low, both of the switches are in an open state regardless of the state of the SEL pin. The control pins can be as high as 44 V.

The TMUX7219 can operate without any external components except for the supply decoupling capacitors. The EN pin has an internal pull-up resistor of 4 M Ω , and SEL pin has internal pull-down resistor of 4 M Ω . If unused, EN pin must be tied to V_{DD} and SEL pin must be tied to GND to ensure the device does not consume additional current as highlighted in [Implications of Slow or Floating CMOS Inputs](#). Unused signal path inputs (S1, S2, or D) should be connected to GND.

7.5 Truth Tables

[Table 7-1](#) show the truth tables for the TMUX7219.

Table 7-1. TMUX7219 Truth Table

EN	SEL	Selected Source Connected To Drain (D) Pin
0	X ⁽¹⁾	All sources are off (HI-Z)
1	0	S1
1	1	S2

(1) X denotes *do not care*.

8 Application and Implementation

Note

Information in the following applications sections is not part of the TI component specification, and TI does not warrant its accuracy or completeness. TI's customers are responsible for determining suitability of components for their purposes, as well as validating and testing their design implementation to confirm system functionality.

8.1 Application Information

TMUX7219 is part of the precision switches and multiplexers family of devices. TMUX7219 offers low RON, low on and off leakage currents, and ultra-low charge injection performance. These properties make TMUX7219 ideal for implementing high precision industrial systems requiring selection of one of two inputs or outputs.

8.2 Typical Applications

8.2.1 Power Amplifier Gate Driver

One application of the TMUX7219 is for input control of a power amplifier gate driver. Utilizing a switch allows a system to control when the DAC is connected to the power amplifier, and can stop biasing the power amplifier by switching the gate to V_{SS} . The wide dual supply range of ± 4.5 V to ± 22 V allows the switch to work with GaN power amplifiers and the wide single supply range 4.5 V to 44 V works well with LDMOS power amplifiers.

Figure 8-1 shows the TMUX7219 configured for control of the power amplifier gate driver in GaN application.

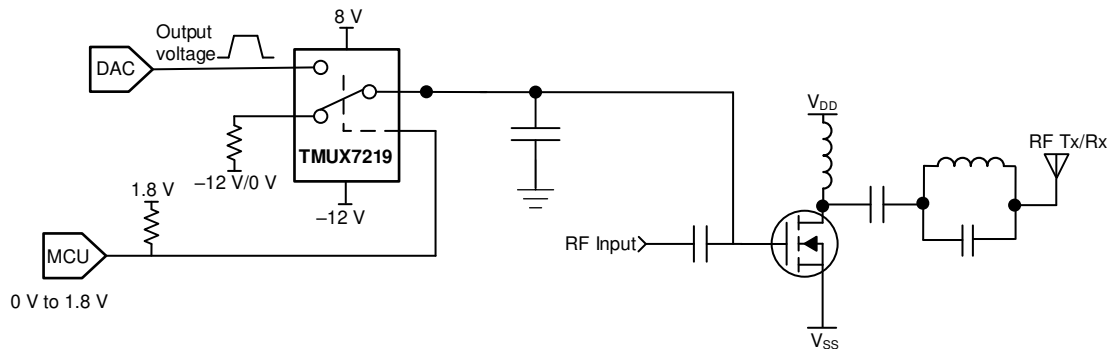

Figure 8-1. Power Amplifier Gate Driver

8.2.1.1 Design Requirements

For this design example, use the parameters listed in Table 8-1.

Table 8-1. Design Parameters

PARAMETERS	VALUES	
	GAN Application	LDMOS Application
Supply (V_{DD})	8 V	5 V
Supply (V_{SS})	-12 V	0 V
MUX I/O signal range	-12 V to 8 V (Rail-to-Rail)	0 V to 5 V (Rail-to-Rail)
Control logic thresholds	1.8 V compatible (up to V_{DD})	1.8 V compatible (up to V_{DD})
EN	EN pulled high to enable the switch	EN pulled high to enable the switch

8.2.1.2 Detailed Design Procedure

The application shown in [Figure 8-1](#) demonstrates how to toggle between the DAC output and low signal voltage for control of a GaN power amplifier using a single control input. The DAC output is utilized to bias the gate of the power amplifier and can be disconnected from the circuit using the select pin of the switch. The TMUX7219 can support 1.8 V logic signals on the control input, allowing the device to interface with low logic controls of an FPGA or MCU. The TMUX7219 can operate without any external components except for the supply decoupling capacitors. The select pin has an internal pull-down resistor to prevent floating input logic. All inputs to the switch must fall within the recommended operating conditions of the TMUX7219 including signal range and continuous current. For this design with a positive supply of 8 V on V_{DD} and negative supply of -12 V on V_{SS} , the signal range can be 8 V to -12 V. The maximum continuous current (I_{DC}) can be up to 440 mA for a wide-range current measurement (for more information, refer to Recommended Operating Conditions).

8.2.1.3 Application Curve

The low on and off leakage currents of TMUX7219 and ultra-low charge injection performance make this device ideal for implementing high precision industrial systems. The TMUX7219 contains specialized architecture to reduce charge injection on the source (S_x) (see [Section 7.3.7](#) for more details). [Figure 8-2](#) shows the plot for the charge injection versus source voltage for the TMUX7219.

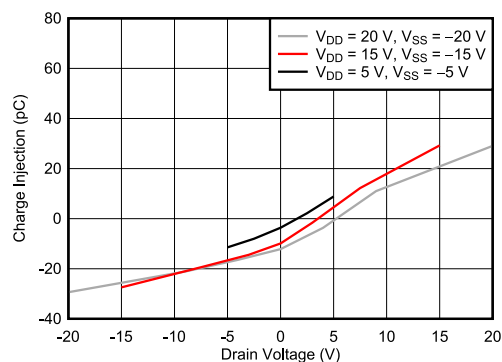

Figure 8-2. Charge Injection vs Source Voltage

8.2.2 Ultrasonic Sensing Gas Meter

Another application of the TMUX7219 is in the ultrasonic sensing gas meter. Ultrasonic sensing of gas flow uses the time of flight (ToF) of an ultrasonic wave and its dependency and behavior in the medium using two transducer pairs for upstream and downstream paths. [Figure 8-3](#) shows a circuit example utilizing the MSP430FR6043 MCU, high voltage low distortion operational amplifiers (THS3091), along with TMUX7219, 2:1 precision switches. The TMUX7219 are needed to select the Rx and Tx path of the transducer. The TMUX7219 offers low on-state resistance and causes a very low signal distortion. The break-before-make feature allows transferring of a signal from one port to another, with a minimal signal distortion. This device also offers a low charge injection which makes this device suitable for high-performance audio and data acquisition systems.

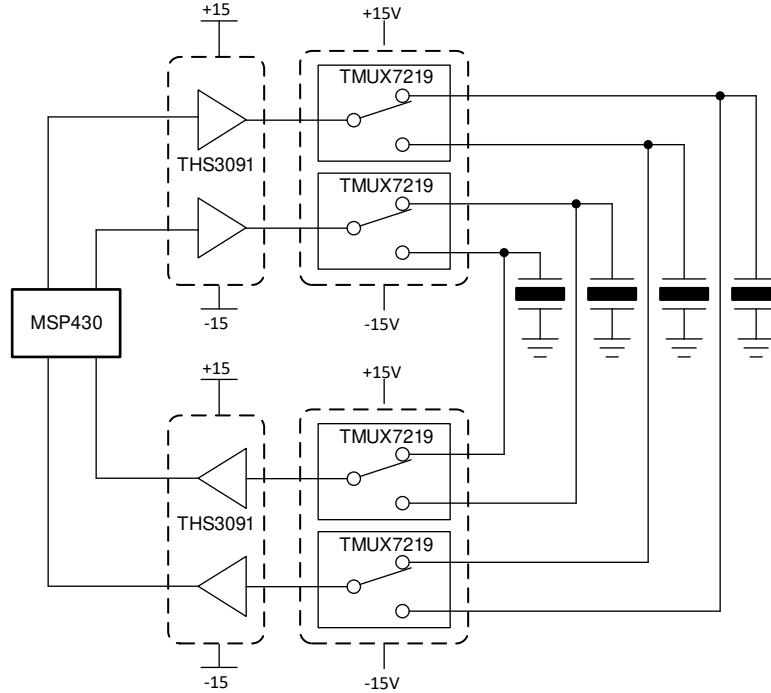

Figure 8-3. Ultrasonic Sensing Gas Meter System

8.2.2.1 Design Requirements

For this design example, use the parameters listed in [Table 8-2](#).

Table 8-2. Design Parameters

PARAMETERS	VALUES
Supply (V_{DD})	15 V
Supply (V_{SS})	-15 V
MUX I/O signal range	-15 V to 15 V (Rail-to-Rail)
Control logic thresholds	1.8 V compatible (up to V_{DD})
EN	EN pulled high to enable the switch
Zero-flow drift (ZFD)	± 250 ps (typical)
Single-shot standard deviation (STD)	<500 ps

8.2.2.2 Detailed Design Procedure

The TMUX7219 can operate without any external components except for the supply decoupling capacitors. All inputs passing through the switch must fall within the recommended operating conditions of the TMUX7219, including signal range and continuous current. For this design with a positive supply of 15 V on V_{DD} and negative supply of -15 V on V_{SS} , the signal range can be -15 V to +15 V and the maximum continuous current can be up to 440 mA, as shown in the *Recommended Operating Conditions*, for a wide-range current measurement. The TMUX7219 device is a bidirectional, single-pole double-throw (SPDT) switch that offers low on-resistance, low leakage, and low power. These features make this device suitable for portable and power sensitive applications such as ultrasonic gas metering systems. For a more detailed analysis of the ultrasonic flow transmitter system, refer to the [reference design](#).

8.2.2.3 Application Curve

The TMUX7219 is capable of switching signals with minimal distortion because of the ultra-low leakage currents and excellent on-resistance flatness. Figure 8-4 shows how the on-resistance for the TMUX7219 varies with different supply voltages.

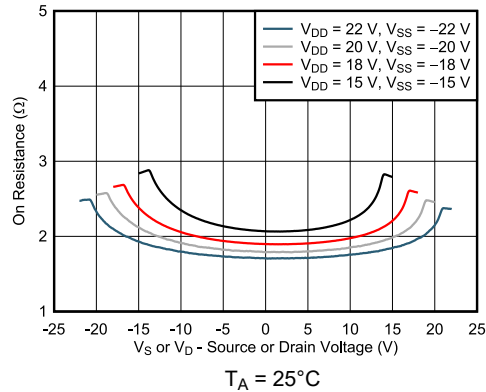

Figure 8-4. On-Resistance vs Source or Drain Voltage

9 Power Supply Recommendations

The TMUX7219 operates across a wide supply range of ± 4.5 V to ± 22 V (4.5 V to 44 V in single-supply mode). The device also performs well with asymmetrical supplies such as $V_{DD} = 12$ V and $V_{SS} = -5$ V.

Power-supply bypassing improves noise margin and prevents switching noise propagation from the supply rails to other components. Good power-supply decoupling is important to achieve optimum performance. For improved supply noise immunity, use a supply decoupling capacitor ranging from 0.1 μ F to 10 μ F at both the V_{DD} and V_{SS} pins to ground. Place the bypass capacitors as close to the power supply pins of the device as possible using low-impedance connections. TI recommends using multi-layer ceramic chip capacitors (MLCCs) that offer low equivalent series resistance (ESR) and inductance (ESL) characteristics for power-supply decoupling purposes. For very sensitive systems, or for systems in harsh noise environments, avoiding the use of vias for connecting the capacitors to the device pins may offer superior noise immunity. The use of multiple vias in parallel lowers the overall inductance and is beneficial for connections to ground and power planes. Always ensure the ground (GND) connection is established before supplies are ramped.

10 Layout

10.1 Layout Guidelines

When a PCB trace turns a corner at a 90° angle, a reflection can occur. A reflection occurs primarily because of the change of width of the trace. At the apex of the turn, the trace width increases to 1.414 times the width. This increase upsets the transmission-line characteristics, especially the distributed capacitance and self-inductance of the trace which results in the reflection. Not all PCB traces can be straight and therefore some traces must turn corners. [Figure 10-1](#) shows progressively better techniques of rounding corners. Only the last example (BEST) maintains constant trace width and minimizes reflections.

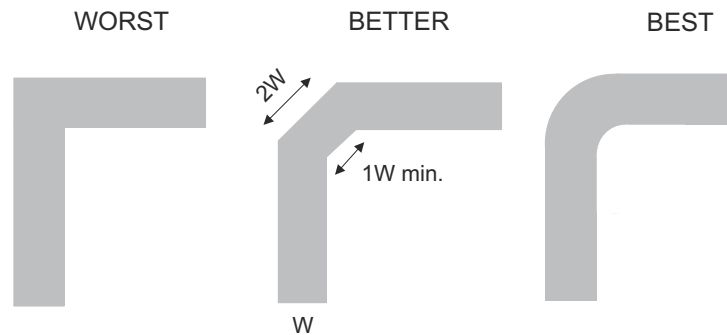

Figure 10-1. Trace Example

Route high-speed signals using a minimum of vias and corners which reduces signal reflections and impedance changes. When a via must be used, increase the clearance size around it to minimize its capacitance. Each via introduces discontinuities in the signal's transmission line and increases the chance of picking up interference from the other layers of the board. Be careful when designing test points, through-hole pins are not recommended at high frequencies.

[Figure 10-2](#) shows an example of a PCB layout with the TMUX7219. Some key considerations are as follows:

- For reliable operation, connect a decoupling capacitor ranging from 0.1 μF to 10 μF between VDD/VSS and GND. We recommend a 0.1 μF and 1 μF capacitor, placing the lowest value capacitor as close to the pin as possible. Make sure that the capacitor voltage rating is sufficient for the supply voltage.
- Keep the input lines as short as possible.
- Use a solid ground plane to help reduce electromagnetic interference (EMI) noise pickup.
- Do not run sensitive analog traces in parallel with digital traces. Avoid crossing digital and analog traces if possible, and only make perpendicular crossings when necessary.
- Using multiple vias in parallel will lower the overall inductance and is beneficial for connection to ground planes.

10.2 Layout Example

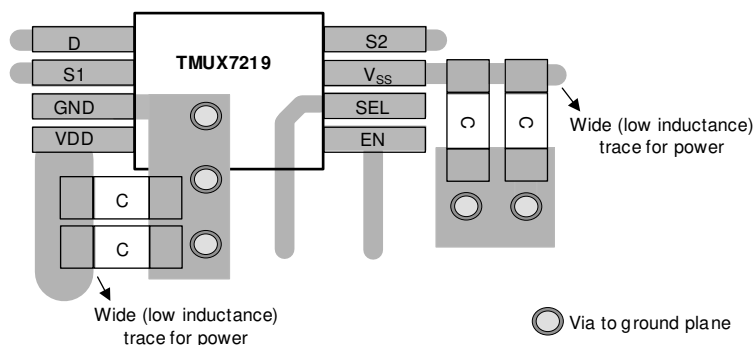

Figure 10-2. TMUX7219DGK Layout Example

11 Device and Documentation Support

11.1 Documentation Support

11.1.1 Related Documentation

For related documentation, see the following:

- Texas Instruments, [Improve Stability Issues with Low CON Multiplexers](#) application brief
- Texas Instruments, [Improving Signal Measurement Accuracy in Automated Test Equipment](#) application brief
- Texas Instruments, [Multiplexers and Signal Switches Glossary](#) application report
- Texas Instruments, [QFN/SON PCB Attachment](#) application report
- Texas Instruments, [Quad Flatpack No-Lead Logic Packages](#) application report
- Texas Instruments, [Simplifying Design with 1.8 V logic Muxes and Switches](#) application brief
- Texas Instruments, [System-Level Protection for High-Voltage Analog Multiplexers](#) application report
- Texas Instruments, [True Differential, 4 x 2 MUX, Analog Front End, Simultaneous-Sampling ADC Circuit](#) application report
- Texas Instruments, [Ultrasonic sensing subsystem reference design for gas flow measurement](#) reference design

11.2 Receiving Notification of Documentation Updates

To receive notification of documentation updates, navigate to the device product folder on ti.com. In the upper right corner, click on *Alert me* to register and receive a weekly digest of any product information that has changed. For change details, review the revision history included in any revised document.

11.3 Support Resources

[TI E2E™ support forums](#) are an engineer's go-to source for fast, verified answers and design help — straight from the experts. Search existing answers or ask your own question to get the quick design help you need.

Linked content is provided "AS IS" by the respective contributors. They do not constitute TI specifications and do not necessarily reflect TI's views; see TI's [Terms of Use](#).

11.4 Trademarks

TI E2E™ is a trademark of Texas Instruments.

All trademarks are the property of their respective owners.

11.5 Electrostatic Discharge Caution



This integrated circuit can be damaged by ESD. Texas Instruments recommends that all integrated circuits be handled with appropriate precautions. Failure to observe proper handling and installation procedures can cause damage.

ESD damage can range from subtle performance degradation to complete device failure. Precision integrated circuits may be more susceptible to damage because very small parametric changes could cause the device not to meet its published specifications.

11.6 Glossary

[TI Glossary](#) This glossary lists and explains terms, acronyms, and definitions.

12 Revision History

NOTE: Page numbers for previous revisions may differ from page numbers in the current version.

Changes from Revision E (August 2022) to Revision F (July 2024)	Page
• Updated IIH specification.....	6

Changes from Revision D (March 2022) to Revision E (August 2022)	Page
• Changed the status of the QFN package from: <i>preview</i> to: <i>active</i>	1

Changes from Revision C (December 2020) to Revision D (March 2022)	Page
• Added WSON package details to the <i>Pin Configuration and Functions</i> section.....	3

Changes from Revision B (December 2020) to Revision C (December 2020)	Page
• Changed the status of the data sheet from: <i>Advanced Information</i> to: <i>Production Data</i>	1
• Added the <i>Integrated Pull-Down Resistor on Logic Pins</i> section.....	28

13 Mechanical, Packaging, and Orderable Information

The following pages include mechanical, packaging, and orderable information. This information is the most current data available for the designated devices. This data is subject to change without notice and revision of this document. For browser-based versions of this data sheet, refer to the left-hand navigation.

PACKAGING INFORMATION

Orderable Device	Status (1)	Package Type	Package Drawing	Pins	Package Qty	Eco Plan (2)	Lead finish/ Ball material (6)	MSL Peak Temp (3)	Op Temp (°C)	Device Marking (4/5)	Samples
PTMUX7219RQXR	ACTIVE	WSO	RQX	8	2500	TBD	Call TI	Call TI	-40 to 125		Samples
TMUX7219DGKR	ACTIVE	VSSOP	DGK	8	2500	RoHS & Green	NIPDAU	Level-1-260C-UNLIM	-40 to 125	X219	Samples
TMUX7219RQXR	ACTIVE	WSO	RQX	8	2500	RoHS & Green	NIPDAU	Level-1-260C-UNLIM	-40 to 125	H219	Samples

(1) The marketing status values are defined as follows:

ACTIVE: Product device recommended for new designs.

LIFEBUY: TI has announced that the device will be discontinued, and a lifetime-buy period is in effect.

NRND: Not recommended for new designs. Device is in production to support existing customers, but TI does not recommend using this part in a new design.

PREVIEW: Device has been announced but is not in production. Samples may or may not be available.

OBSOLETE: TI has discontinued the production of the device.

(2) **RoHS:** TI defines "RoHS" to mean semiconductor products that are compliant with the current EU RoHS requirements for all 10 RoHS substances, including the requirement that RoHS substance do not exceed 0.1% by weight in homogeneous materials. Where designed to be soldered at high temperatures, "RoHS" products are suitable for use in specified lead-free processes. TI may reference these types of products as "Pb-Free".

RoHS Exempt: TI defines "RoHS Exempt" to mean products that contain lead but are compliant with EU RoHS pursuant to a specific EU RoHS exemption.

Green: TI defines "Green" to mean the content of Chlorine (Cl) and Bromine (Br) based flame retardants meet JS709B low halogen requirements of <=1000ppm threshold. Antimony trioxide based flame retardants must also meet the <=1000ppm threshold requirement.

(3) MSL, Peak Temp. - The Moisture Sensitivity Level rating according to the JEDEC industry standard classifications, and peak solder temperature.

(4) There may be additional marking, which relates to the logo, the lot trace code information, or the environmental category on the device.

(5) Multiple Device Markings will be inside parentheses. Only one Device Marking contained in parentheses and separated by a "~" will appear on a device. If a line is indented then it is a continuation of the previous line and the two combined represent the entire Device Marking for that device.

(6) Lead finish/Ball material - Orderable Devices may have multiple material finish options. Finish options are separated by a vertical ruled line. Lead finish/Ball material values may wrap to two lines if the finish value exceeds the maximum column width.

Important Information and Disclaimer:The information provided on this page represents TI's knowledge and belief as of the date that it is provided. TI bases its knowledge and belief on information provided by third parties, and makes no representation or warranty as to the accuracy of such information. Efforts are underway to better integrate information from third parties. TI has taken and continues to take reasonable steps to provide representative and accurate information but may not have conducted destructive testing or chemical analysis on incoming materials and chemicals. TI and TI suppliers consider certain information to be proprietary, and thus CAS numbers and other limited information may not be available for release.

In no event shall TI's liability arising out of such information exceed the total purchase price of the TI part(s) at issue in this document sold by TI to Customer on an annual basis.

OTHER QUALIFIED VERSIONS OF TMUX7219 :

- Automotive : [TMUX7219-Q1](#)

NOTE: Qualified Version Definitions:

- Automotive - Q100 devices qualified for high-reliability automotive applications targeting zero defects

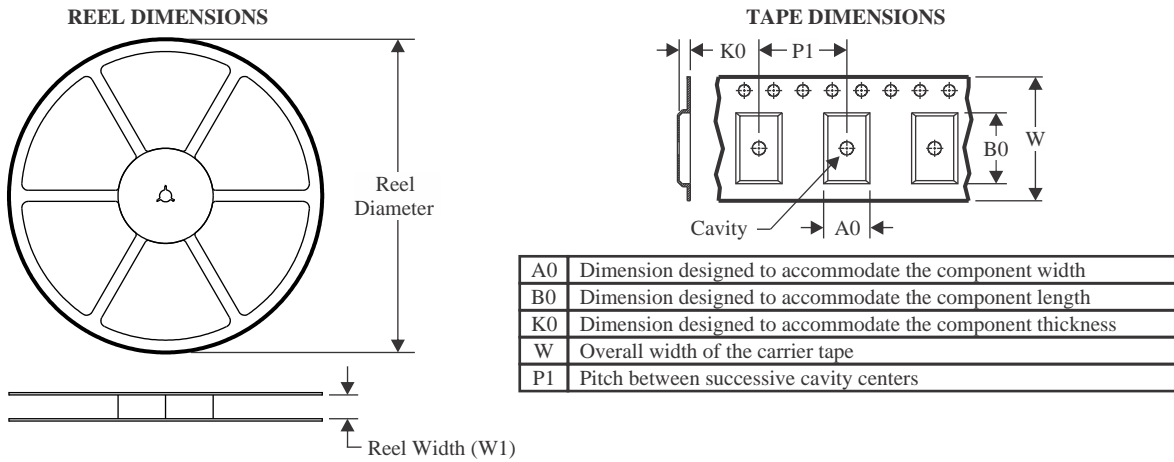
TAPE AND REEL INFORMATION

QUADRANT ASSIGNMENTS FOR PIN 1 ORIENTATION IN TAPE

*All dimensions are nominal

Device	Package Type	Package Drawing	Pins	SPQ	Reel Diameter (mm)	Reel Width W1 (mm)	A0 (mm)	B0 (mm)	K0 (mm)	P1 (mm)	W (mm)	Pin1 Quadrant
TMUX7219DGKR	VSSOP	DGK	8	2500	330.0	12.4	5.3	3.4	1.4	8.0	12.0	Q1

TAPE AND REEL BOX DIMENSIONS

*All dimensions are nominal

Device	Package Type	Package Drawing	Pins	SPQ	Length (mm)	Width (mm)	Height (mm)
TMUX7219DGKR	VSSOP	DGK	8	2500	366.0	364.0	50.0

RQX0008A

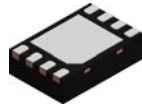

PACKAGE OUTLINE

WSON - 0.8 mm max height

PLASTIC SMALL OUTLINE - NO LEAD

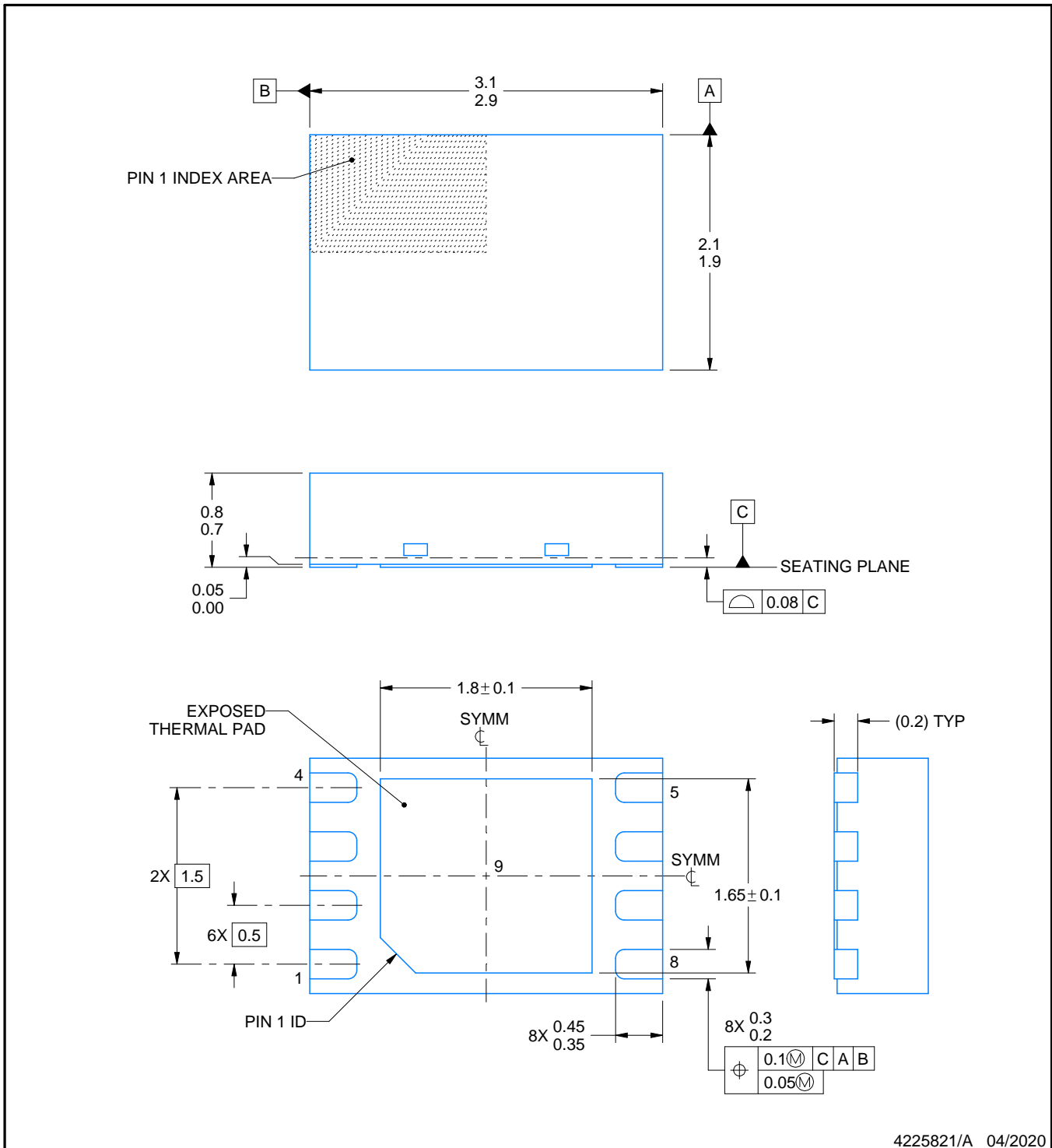

4225821/A 04/2020

NOTES:

1. All linear dimensions are in millimeters. Any dimensions in parenthesis are for reference only. Dimensioning and tolerancing per ASME Y14.5M.
2. This drawing is subject to change without notice.
3. The package thermal pad must be soldered to the printed circuit board for thermal and mechanical performance.

EXAMPLE STENCIL DESIGN

RQX0008A

WSON - 0.8 mm max height

PLASTIC SMALL OUTLINE - NO LEAD

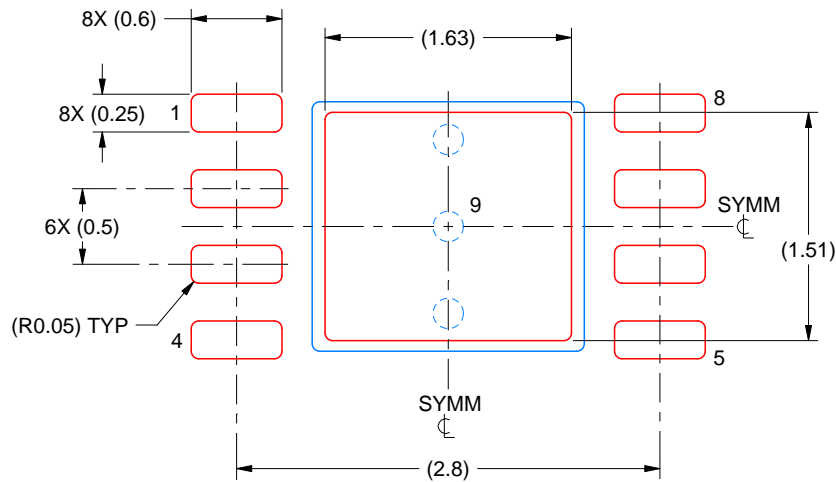

SOLDER PASTE EXAMPLE
BASED ON 0.125 MM THICK STENCIL
SCALE: 20X

EXPOSED PAD 9
83% PRINTED SOLDER COVERAGE BY AREA UNDER PACKAGE

4225821/A 04/2020

NOTES: (continued)

6. Laser cutting apertures with trapezoidal walls and rounded corners may offer better paste release. IPC-7525 may have alternate design recommendations.

DGK0008A



PACKAGE OUTLINE

VSSOP - 1.1 mm max height

SMALL OUTLINE PACKAGE



4214862/A 04/2023

NOTES:

PowerPAD is a trademark of Texas Instruments.

1. All linear dimensions are in millimeters. Any dimensions in parenthesis are for reference only. Dimensioning and tolerancing per ASME Y14.5M.
2. This drawing is subject to change without notice.
3. This dimension does not include mold flash, protrusions, or gate burrs. Mold flash, protrusions, or gate burrs shall not exceed 0.15 mm per side.
4. This dimension does not include interlead flash. Interlead flash shall not exceed 0.25 mm per side.
5. Reference JEDEC registration MO-187.

EXAMPLE BOARD LAYOUT

DGK0008A

™ VSSOP - 1.1 mm max height

SMALL OUTLINE PACKAGE



LAND PATTERN EXAMPLE
EXPOSED METAL SHOWN
SCALE: 15X



SOLDER MASK DETAILS

4214862/A 04/2023

NOTES: (continued)

6. Publication IPC-7351 may have alternate designs.
7. Solder mask tolerances between and around signal pads can vary based on board fabrication site.
8. Vias are optional depending on application, refer to device data sheet. If any vias are implemented, refer to their locations shown on this view. It is recommended that vias under paste be filled, plugged or tented.
9. Size of metal pad may vary due to creepage requirement.

EXAMPLE STENCIL DESIGN

DGK0008A

™ VSSOP - 1.1 mm max height

SMALL OUTLINE PACKAGE



SOLDER PASTE EXAMPLE
SCALE: 15X

4214862/A 04/2023

NOTES: (continued)

11. Laser cutting apertures with trapezoidal walls and rounded corners may offer better paste release. IPC-7525 may have alternate design recommendations.
12. Board assembly site may have different recommendations for stencil design.

IMPORTANT NOTICE AND DISCLAIMER

TI PROVIDES TECHNICAL AND RELIABILITY DATA (INCLUDING DATA SHEETS), DESIGN RESOURCES (INCLUDING REFERENCE DESIGNS), APPLICATION OR OTHER DESIGN ADVICE, WEB TOOLS, SAFETY INFORMATION, AND OTHER RESOURCES "AS IS" AND WITH ALL FAULTS, AND DISCLAIMS ALL WARRANTIES, EXPRESS AND IMPLIED, INCLUDING WITHOUT LIMITATION ANY IMPLIED WARRANTIES OF MERCHANTABILITY, FITNESS FOR A PARTICULAR PURPOSE OR NON-INFRINGEMENT OF THIRD PARTY INTELLECTUAL PROPERTY RIGHTS.

These resources are intended for skilled developers designing with TI products. You are solely responsible for (1) selecting the appropriate TI products for your application, (2) designing, validating and testing your application, and (3) ensuring your application meets applicable standards, and any other safety, security, regulatory or other requirements.

These resources are subject to change without notice. TI grants you permission to use these resources only for development of an application that uses the TI products described in the resource. Other reproduction and display of these resources is prohibited. No license is granted to any other TI intellectual property right or to any third party intellectual property right. TI disclaims responsibility for, and you will fully indemnify TI and its representatives against, any claims, damages, costs, losses, and liabilities arising out of your use of these resources.

TI's products are provided subject to [TI's Terms of Sale](#) or other applicable terms available either on [ti.com](https://www.ti.com) or provided in conjunction with such TI products. TI's provision of these resources does not expand or otherwise alter TI's applicable warranties or warranty disclaimers for TI products.

TI objects to and rejects any additional or different terms you may have proposed.

Mailing Address: Texas Instruments, Post Office Box 655303, Dallas, Texas 75265
Copyright © 2024, Texas Instruments Incorporated