

uA9638C Dual High-Speed Differential Line Driver

1 Features

- Meets or exceeds ANSI standard EIA/TIA-422-B
- Operates from a single 5V power supply
- Drives loads as low as 50Ω up to 15Mbps
- TTL- and CMOS-input compatibility
- Output short-circuit protection
- Interchangeable with DS9638

2 Applications

- [Factory automation](#)
- ATM and cash counters
- [Smart grid](#)
- AC and [servo motor drives](#)

3 Description

The uA9638 is a dual high-speed differential line driver designed to meet ANSI Standard EIA/TIA-422-B. The inputs are TTL and CMOS compatible and have input clamp diodes. Schottky-diode-clamped transistors are used to minimize propagation delay time. This device operates from a single 5V power supply and is supplied in an 8-pin package.

The uA9638 provides the current needed to drive low-impedance loads at high speeds. Typically used with twisted-pair cabling and differential receiver(s), base-band data transmission can be accomplished up to and exceeding 15Mbps in properly designed systems. The uA9637A dual line receiver is commonly used as the receiver. For even faster switching speeds in the same pin configuration, see the SN75ALS191.

The uA9638 is characterized for operation from 0°C to 70°C.

Package Information

PART NUMBER	PACKAGE ⁽¹⁾	PACKAGE SIZE ⁽²⁾
uA9638	SOIC (D, 8)	4.9mm × 6mm
	PDIP (P, 8)	9.81mm × 9.43mm

(1) For more information, see [Section 10](#).

(2) The package size (length × width) is a nominal value and includes pins, where applicable.

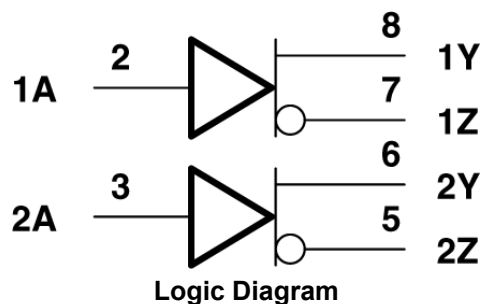
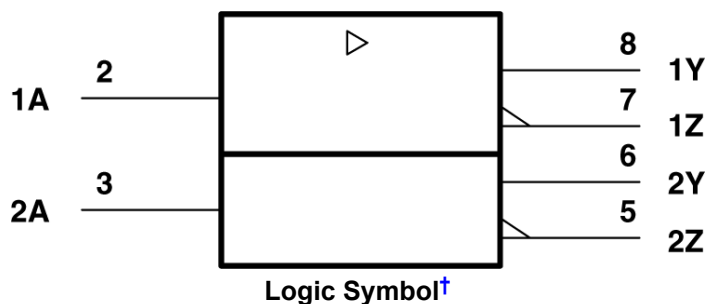

† This symbol is in accordance with ANSI/IEEE Std 91-1984 and IEC Publication 617-12.



Table of Contents

1 Features	1	6 Parameter Measurement Information	6
2 Applications	1	7 Device Functional Modes	7
3 Description	1	8 Device and Documentation Support	8
4 Pin Configuration and Functions	3	8.1 Support Resources.....	8
5 Specifications	4	8.2 Trademarks.....	8
5.1 Absolute Maximum Ratings.....	4	8.3 Electrostatic Discharge Caution.....	8
5.2 Dissipation Rating Table.....	4	8.4 Glossary.....	8
5.3 Recommended Operating Conditions.....	4	9 Revision History	8
5.4 Thermal Information.....	4	10 Mechanical, Packaging, and Orderable	
5.5 Electrical Characteristics.....	5	Information	8
5.6 Switching Characteristics.....	5		

4 Pin Configuration and Functions

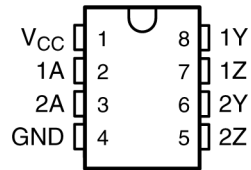

**Figure 4-1. D (SOIC) or P (PDIP) Package
(Top View)**

Table 4-1. Pin Functions

PIN		TYPE ⁽¹⁾	DESCRIPTION
NAME	NO.		
V _{CC}	1	P	5V Supply Positive Terminal Connection
1A	2	I	Single Ended Data Input for Channel 1
2A	3	I	Single Ended Data Input for Channel 2
GND	4	GND	Device Ground
2Z	5	O	Inverting Output of Differential Driver for Channel 2
2Y	6	O	Non-Inverting Output of Differential Driver for Channel 2
1Z	7	O	Inverting Output of Differential Driver for Channel 1
1Y	8	O	Non-Inverting Output of Differential Driver for Channel 1

(1) Signal Types: I = Input, O = Output, I/O = Input or Output, P = Power, GND = GND.

5 Specifications

5.1 Absolute Maximum Ratings

over operating free-air temperature range (unless otherwise noted) ⁽¹⁾

		MIN	MAX	UNIT
V_{CC}	Supply voltage range	-0.5	7	V
V_I	Input voltage range	-0.5	7	V
	Continuous total power dissipation	See Dissipation Rating Table		
T_A	Operating free-air temperature range	0	70	°C
T_{stg}	Storage temperature range	-65	150	°C
	Lead temperature 1,6 mm (1/16 inch) from 10 seconds		260	°C

- (1) Stresses beyond those listed under “absolute maximum ratings” may cause permanent damage to the device. These are stress ratings only, and functional operation of the device at these or any other conditions beyond those indicated under “recommended operating conditions” is not implied. Exposure to absolute-maximum-rated conditions for extended periods may affect device reliability. NOTE 1: Voltage values except differential output voltages are with respect to network GND.

5.2 Dissipation Rating Table

PACKAGE	$T_A = 25\text{ °C}$ POWER RATING	DERATING FACTOR ABOVE $T_A = 25\text{ °C}$	$T_A = 70\text{ °C}$ POWER RATING
D	725 mW	5.8 mW/°C	464 mW
P	1000 mW	8.0 mW/°C	640 mW

5.3 Recommended Operating Conditions

	MIN	NOM	MAX	UNIT
Supply voltage, V_{CC}	4.75	5	5.25	V
High-level input voltage, V_{IH}	2			V
Low-level input voltage, V_{IL}			0.8	V
High-level output current, I_{OH}			-50	mA
Low-level output current, I_{OL}			50	mA
Operating free-air temperature, T_A	0		70	°C

5.4 Thermal Information

THERMAL METRIC ⁽¹⁾		D (SOIC)	P (PDIP)	UNIT
		8-Pins		
$R_{\theta JA}$	Junction-to-ambient thermal resistance	116.7	84.3	°C/W
$R_{\theta JC(top)}$	Junction-to-case (top) thermal resistance	56.3	65.4	°C/W
$R_{\theta JB}$	Junction-to-board thermal resistance	63.4	62.1	°C/W
Ψ_{JT}	Junction-to-top characterization parameter	8.8	31.3	°C/W
Ψ_{JB}	Junction-to-board characterization parameter	62.6	60.4	°C/W
$R_{\theta JC(bot)}$	Junction-to-case (bottom) thermal resistance	N/A	N/A	°C/W

- (1) For more information about traditional and new thermal metrics, see the [Semiconductor and IC package thermal metrics](#) application report.

5.5 Electrical Characteristics

over operating free-air temperature range (unless otherwise noted)

PARAMETER		TEST CONDITIONS			MIN	TYP ⁽¹⁾	MAX	UNIT		
V _{IK}	Input clamp voltage	V _{CC} = 4.75V,	I _I = -18mA		-1		-1.2	V		
V _{OH}	High-level output voltage	V _{CC} = 4.75V,	V _{IH} = 2V,	I _{OH} = -10mA	2.5	3.5		V		
		V _{IL} = 0.8V		I _{OH} = -40mA	2					
V _{OL}	Low-level output voltage	V _{CC} = 4.75V, I _{OL} = 40mA	V _{IH} = 2V,	V _{IL} = 0.8V,			0.5	V		
V _{OD1}	Magnitude of differential output voltage	V _{CC} = 5.25V,	I _O = 0				2V _{OD2}	V		
V _{OD2}	Magnitude of differential output voltage	V _{CC} = 4.75V to 5.25V, See Figure 6-1 R _L = 100Ω			2			V		
Δ V _{OD}	Change in magnitude of differential output voltage ⁽²⁾							±0.4		V
V _{OC}	Common-mode output voltage ⁽³⁾								3	V
Δ V _{OC}	Change in magnitude of common-mode output voltage ⁽²⁾								±0.4	V
I _O	Output current with power off	V _{CC} = 0	V _O = 6V		0.1		100	μA		
			V _O = -0.25V				-100			
			V _O = -0.25V to 6V				±100			
I _I	Input current	V _{CC} = 5.25V,	V _I = 5.5V				50	μA		
I _{IH}	High-level input current	V _{CC} = 5.25V,	V _I = 2.7V				25	μA		
I _{IL}	Low-level input current	V _{CC} = 5.25V,	V _I = 0.5V				-200	μA		
I _{OS}	Short-circuit output current ⁽⁴⁾	V _{CC} = 5.25V,	V _O = 0		-50		-150	mA		
I _{CC}	Supply current (both drivers)	V _{CC} = 5.25V,	No load,	All inputs at 0V	45		65	mA		

(1) All typical values are at V_{CC} = 5 V and T_A = 25°C.

(2) Δ|V_{OD}| and Δ|V_{OC}| are the changes in magnitude of V_{OD} and V_{OC}, respectively, that occur when the input is changed from a high level to a low level or vice versa.

(3) In Standard EIA-422-A, V_{OC}, which is the average of the two output voltages with respect to ground, is called output offset voltage, V_{OS}.

(4) Only one output at a time should be shorted, and duration of the short circuit should not exceed one second.

5.6 Switching Characteristics

V_{CC} = 5V, T_A = 25°C

PARAMETER		TEST CONDITIONS			MIN	TYP	MAX	UNIT
t _{d(OD)}	Differential output delay time	C _L = 15pF,	R _L = 100	See Figure 6-2		10	20	ns
t _{t(OD)}	Differential output transition time					10	20	ns
t _{sk(o)}	Output skew	See Figure 6-2						1

6 Parameter Measurement Information

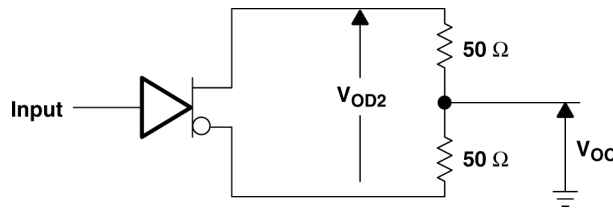
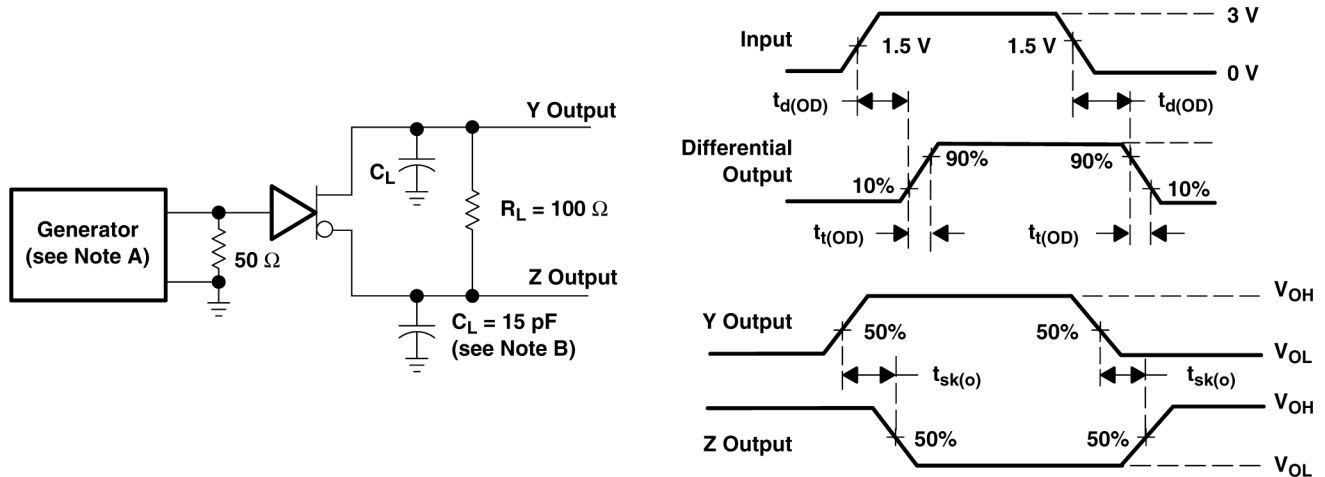

Figure 6-1. Differential and Common-Mode Output Voltages



TEST CIRCUIT

VOLTAGE WAVEFORMS

- A. The input pulse generator has the following characteristics: $Z_O = 50\Omega$, $PRR \leq 500\text{kHz}$, $t_w = 100\text{ns}$, $t_r = \leq 5\text{ns}$.
- B. C_L includes probe and jig capacitance.

Figure 6-2. Test Circuit and Voltage Waveforms

7 Device Functional Modes

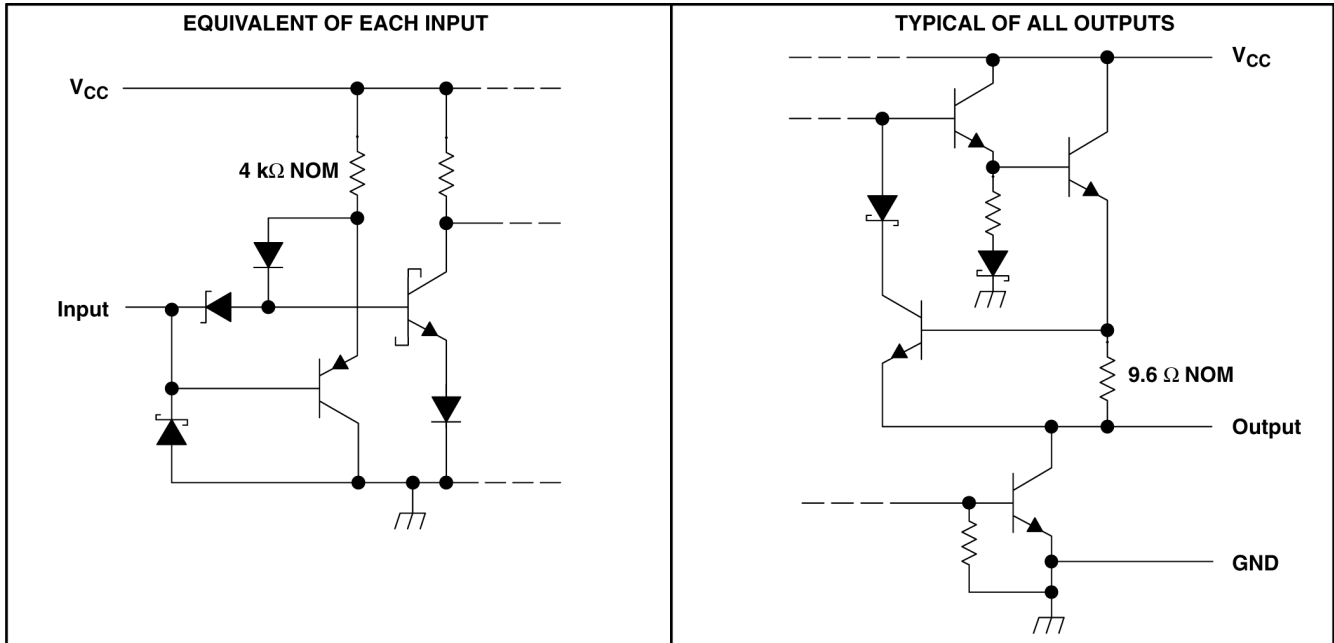

Figure 7-1. Schematics of Inputs and Outputs

8 Device and Documentation Support

8.1 Support Resources

TI E2E™ support forums are an engineer's go-to source for fast, verified answers and design help — straight from the experts. Search existing answers or ask your own question to get the quick design help you need.

Linked content is provided "AS IS" by the respective contributors. They do not constitute TI specifications and do not necessarily reflect TI's views; see TI's [Terms of Use](#).

8.2 Trademarks

TI E2E™ is a trademark of Texas Instruments.

All trademarks are the property of their respective owners.

8.3 Electrostatic Discharge Caution



This integrated circuit can be damaged by ESD. Texas Instruments recommends that all integrated circuits be handled with appropriate precautions. Failure to observe proper handling and installation procedures can cause damage.

ESD damage can range from subtle performance degradation to complete device failure. Precision integrated circuits may be more susceptible to damage because very small parametric changes could cause the device not to meet its published specifications.

8.4 Glossary

[TI Glossary](#) This glossary lists and explains terms, acronyms, and definitions.

9 Revision History

NOTE: Page numbers for previous revisions may differ from page numbers in the current version.

Changes from Revision C (April 1994) to Revision D (March 2024)	Page
• Changed the numbering format for tables, figures, and cross-references throughout the document.....	1

10 Mechanical, Packaging, and Orderable Information

The following pages include mechanical, packaging, and orderable information. This information is the most current data available for the designated devices. This data is subject to change without notice and revision of this document. For browser-based versions of this data sheet, refer to the left-hand navigation.

PACKAGING INFORMATION

Orderable Device	Status (1)	Package Type	Package Drawing	Pins	Package Qty	Eco Plan (2)	Lead finish/ Ball material (6)	MSL Peak Temp (3)	Op Temp (°C)	Device Marking (4/5)	Samples
UA9638CDR	ACTIVE	SOIC	D	8	2500	RoHS & Green	NIPDAU	Level-2-260C-1 YEAR	0 to 70	9638C	Samples
UA9638CDRG4	ACTIVE	SOIC	D	8	2500	RoHS & Green	NIPDAU	Level-2-260C-1 YEAR	0 to 70	9638C	Samples
UA9638CP	ACTIVE	PDIP	P	8	50	RoHS & Green	NIPDAU	N / A for Pkg Type	0 to 70	UA9638CP	Samples
UA9638CPE4	ACTIVE	PDIP	P	8	50	RoHS & Green	NIPDAU	N / A for Pkg Type	0 to 70	UA9638CP	Samples

(1) The marketing status values are defined as follows:

ACTIVE: Product device recommended for new designs.

LIFEBUY: TI has announced that the device will be discontinued, and a lifetime-buy period is in effect.

NRND: Not recommended for new designs. Device is in production to support existing customers, but TI does not recommend using this part in a new design.

PREVIEW: Device has been announced but is not in production. Samples may or may not be available.

OBSELETE: TI has discontinued the production of the device.

(2) **RoHS:** TI defines "RoHS" to mean semiconductor products that are compliant with the current EU RoHS requirements for all 10 RoHS substances, including the requirement that RoHS substance do not exceed 0.1% by weight in homogeneous materials. Where designed to be soldered at high temperatures, "RoHS" products are suitable for use in specified lead-free processes. TI may reference these types of products as "Pb-Free".

RoHS Exempt: TI defines "RoHS Exempt" to mean products that contain lead but are compliant with EU RoHS pursuant to a specific EU RoHS exemption.

Green: TI defines "Green" to mean the content of Chlorine (Cl) and Bromine (Br) based flame retardants meet JS709B low halogen requirements of <=1000ppm threshold. Antimony trioxide based flame retardants must also meet the <=1000ppm threshold requirement.

(3) MSL, Peak Temp. - The Moisture Sensitivity Level rating according to the JEDEC industry standard classifications, and peak solder temperature.

(4) There may be additional marking, which relates to the logo, the lot trace code information, or the environmental category on the device.

(5) Multiple Device Markings will be inside parentheses. Only one Device Marking contained in parentheses and separated by a "-" will appear on a device. If a line is indented then it is a continuation of the previous line and the two combined represent the entire Device Marking for that device.

(6) Lead finish/Ball material - Orderable Devices may have multiple material finish options. Finish options are separated by a vertical ruled line. Lead finish/Ball material values may wrap to two lines if the finish value exceeds the maximum column width.

Important Information and Disclaimer:The information provided on this page represents TI's knowledge and belief as of the date that it is provided. TI bases its knowledge and belief on information provided by third parties, and makes no representation or warranty as to the accuracy of such information. Efforts are underway to better integrate information from third parties. TI has taken and

continues to take reasonable steps to provide representative and accurate information but may not have conducted destructive testing or chemical analysis on incoming materials and chemicals. TI and TI suppliers consider certain information to be proprietary, and thus CAS numbers and other limited information may not be available for release.

In no event shall TI's liability arising out of such information exceed the total purchase price of the TI part(s) at issue in this document sold by TI to Customer on an annual basis.

TAPE AND REEL INFORMATION

QUADRANT ASSIGNMENTS FOR PIN 1 ORIENTATION IN TAPE

*All dimensions are nominal

Device	Package Type	Package Drawing	Pins	SPQ	Reel Diameter (mm)	Reel Width W1 (mm)	A0 (mm)	B0 (mm)	K0 (mm)	P1 (mm)	W (mm)	Pin1 Quadrant
UA9638CDR	SOIC	D	8	2500	330.0	12.4	6.4	5.2	2.1	8.0	12.0	Q1

TAPE AND REEL BOX DIMENSIONS



*All dimensions are nominal

Device	Package Type	Package Drawing	Pins	SPQ	Length (mm)	Width (mm)	Height (mm)
UA9638CDR	SOIC	D	8	2500	340.5	338.1	20.6

TUBE

*All dimensions are nominal

Device	Package Name	Package Type	Pins	SPQ	L (mm)	W (mm)	T (μm)	B (mm)
UA9638CD	D	SOIC	8	75	507	8	3940	4.32
UA9638CDE4	D	SOIC	8	75	507	8	3940	4.32
UA9638CP	P	PDIP	8	50	506	13.97	11230	4.32
UA9638CPE4	P	PDIP	8	50	506	13.97	11230	4.32



D0008A

PACKAGE OUTLINE

SOIC - 1.75 mm max height

SMALL OUTLINE INTEGRATED CIRCUIT



4214825/C 02/2019

NOTES:

- Linear dimensions are in inches [millimeters]. Dimensions in parenthesis are for reference only. Controlling dimensions are in inches. Dimensioning and tolerancing per ASME Y14.5M.
- This drawing is subject to change without notice.
- This dimension does not include mold flash, protrusions, or gate burrs. Mold flash, protrusions, or gate burrs shall not exceed $.006$ [0.15] per side.
- This dimension does not include interlead flash.
- Reference JEDEC registration MS-012, variation AA.

EXAMPLE BOARD LAYOUT

D0008A

SOIC - 1.75 mm max height

SMALL OUTLINE INTEGRATED CIRCUIT



LAND PATTERN EXAMPLE
 EXPOSED METAL SHOWN
 SCALE:8X



SOLDER MASK DETAILS

4214825/C 02/2019

NOTES: (continued)

6. Publication IPC-7351 may have alternate designs.

7. Solder mask tolerances between and around signal pads can vary based on board fabrication site.

EXAMPLE STENCIL DESIGN

D0008A

SOIC - 1.75 mm max height

SMALL OUTLINE INTEGRATED CIRCUIT



SOLDER PASTE EXAMPLE
BASED ON .005 INCH [0.125 MM] THICK STENCIL
SCALE:8X

4214825/C 02/2019

NOTES: (continued)

8. Laser cutting apertures with trapezoidal walls and rounded corners may offer better paste release. IPC-7525 may have alternate design recommendations.
9. Board assembly site may have different recommendations for stencil design.

P (R-PDIP-T8)

PLASTIC DUAL-IN-LINE PACKAGE



- NOTES:
- A. All linear dimensions are in inches (millimeters).
 - B. This drawing is subject to change without notice.
 - C. Falls within JEDEC MS-001 variation BA.

IMPORTANT NOTICE AND DISCLAIMER

TI PROVIDES TECHNICAL AND RELIABILITY DATA (INCLUDING DATA SHEETS), DESIGN RESOURCES (INCLUDING REFERENCE DESIGNS), APPLICATION OR OTHER DESIGN ADVICE, WEB TOOLS, SAFETY INFORMATION, AND OTHER RESOURCES "AS IS" AND WITH ALL FAULTS, AND DISCLAIMS ALL WARRANTIES, EXPRESS AND IMPLIED, INCLUDING WITHOUT LIMITATION ANY IMPLIED WARRANTIES OF MERCHANTABILITY, FITNESS FOR A PARTICULAR PURPOSE OR NON-INFRINGEMENT OF THIRD PARTY INTELLECTUAL PROPERTY RIGHTS.

These resources are intended for skilled developers designing with TI products. You are solely responsible for (1) selecting the appropriate TI products for your application, (2) designing, validating and testing your application, and (3) ensuring your application meets applicable standards, and any other safety, security, regulatory or other requirements.

These resources are subject to change without notice. TI grants you permission to use these resources only for development of an application that uses the TI products described in the resource. Other reproduction and display of these resources is prohibited. No license is granted to any other TI intellectual property right or to any third party intellectual property right. TI disclaims responsibility for, and you will fully indemnify TI and its representatives against, any claims, damages, costs, losses, and liabilities arising out of your use of these resources.

TI's products are provided subject to [TI's Terms of Sale](#) or other applicable terms available either on [ti.com](https://www.ti.com) or provided in conjunction with such TI products. TI's provision of these resources does not expand or otherwise alter TI's applicable warranties or warranty disclaimers for TI products.

TI objects to and rejects any additional or different terms you may have proposed.

Mailing Address: Texas Instruments, Post Office Box 655303, Dallas, Texas 75265
Copyright © 2024, Texas Instruments Incorporated