

SN75ALS192 Quadruple Differential Line Driver

1 Features

- Meets or Exceeds the Requirements of ANSI Standard EIA/TIA-422-B and ITU Recommendation V.11
- Designed to Operate up to 20 Mbaud
- 3-State TTL Compatible
- Single 5V Supply Operation
- High Output Impedance in Power-Off Condition
- Complementary Output-Enable Inputs
- Improved Replacement for the AM26LS31

2 Applications

- [Factory automation](#)
- ATM and cash counters
- [Smart grid](#)
- AC and [servo motor drives](#)

3 Description

The four differential line drivers are designed for data transmission over twisted-pair or parallel-wire transmission lines. They meet the requirements of ANSI Standard EIA/TIA-422-B and ITU Recommendations V.11 and are compatible with 3-state TTL circuits. Advanced low-power Schottky technology provides high speed without the usual power penalties. Standby supply current is typically only 26mA, while typical propagation delay time is less than 10ns.

High-impedance inputs maintain low input currents, less than μA for a high level and less than $100\mu\text{A}$ for a low level. Complementary output-enable inputs (G and \bar{G}) allow these devices to be enabled at either a high input level or low input level. The SN75ALS192 is capable of data rates in excess of 20 Mbit/s and is designed to operate with the SN75ALS193 quadruple line receiver.

The SN75ALS192 is characterized for operation from 0°C to 70°C .

Package Information

PART NUMBER	PACKAGE ⁽¹⁾	PACKAGE SIZE ⁽²⁾
SN75ALS192	SOIC (D, 16)	9.9mm × 6mm
	SO (NS, 16)	10.2mm × 7.8mm

(1) For more information, see [Section 10](#).

(2) The package size (length × width) is a nominal value and includes pins, where applicable.

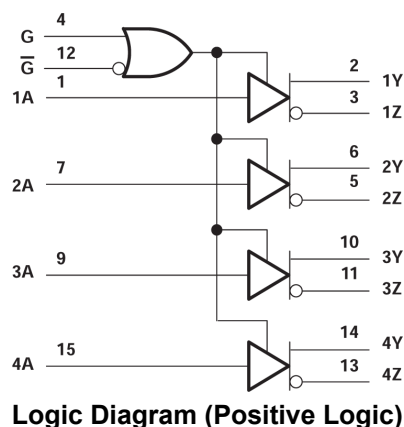
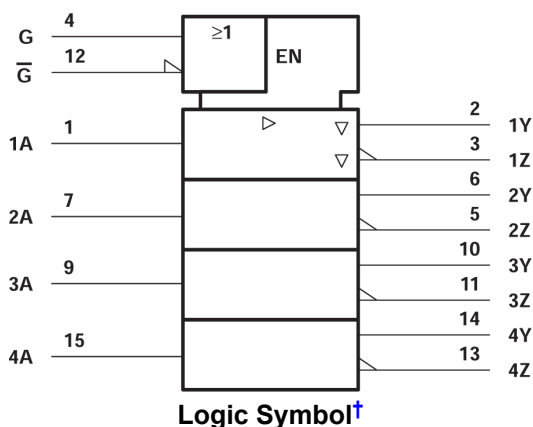

[†] This symbol is in accordance with ANSI/IEEE Std 91-1984 and IEC Publication 617-12.

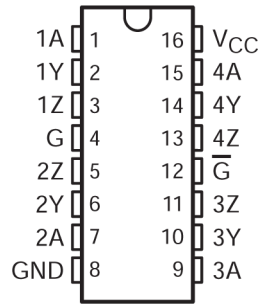

Table of Contents

1 Features	1	6 Parameter Measurement Information	9
2 Applications	1	7 Device Functional Modes	10
3 Description	1	8 Device and Documentation Support	11
4 Pin Configuration and Functions	3	8.1 Receiving Notification of Documentation Updates....	11
5 Specifications	4	8.2 Support Resources.....	11
5.1 Absolute Maximum Ratings.....	4	8.3 Trademarks.....	11
5.2 Dissipation Rating Table.....	4	8.4 Electrostatic Discharge Caution.....	11
5.3 Recommended Operating Conditions.....	4	8.5 Glossary.....	11
5.4 Thermal Information.....	4	9 Revision History	11
5.5 Electrical Characteristics.....	5	10 Mechanical, Packaging, and Orderable Information	11
5.6 Switching Characteristics.....	5		
5.7 Typical Characteristics [†]	6		

[†] Operation of the device at these or any other conditions beyond those indicated under “recommended operating conditions” is not implied.

4 Pin Configuration and Functions



**Figure 4-1. D or NS Package
(Top View)**

Table 4-1. Pin Functions

PIN		TYPE ⁽¹⁾	DESCRIPTION
NAME	NO.		
1A	1	I	Single Ended Data Input for Channel 1
1Y	2	O	Non-Inverting Output for Differential Driver on Channel 1
1Z	3	O	Inverting Output of Differential Driver on Channel 1
G	4	I	Active High Enable Input (OR'd with \bar{G})
2Z	5	O	Inverting Output of Differential Driver on Channel 2
2Y	6	O	Non-Inverting Output for Differential Driver on Channel 2
2A	7	I	Single Ended Data Input for Channel 2
GND	8	GND	Device Ground
3A	9	I	Single Ended Data Input for Channel 3
3Y	10	O	Non-Inverting Output for Differential Driver on Channel 3
3Z	11	O	Inverting Output of Differential Driver on Channel 3
\bar{G}	12	I	Active Low Enable Input (OR'd with G)
4Z	13	O	Inverting Output of Differential Driver on Channel 4
4Y	14	O	Non-Inverting Output for Differential Driver on Channel 4
4A	15	I	Single Ended Data Input for Channel 4
V _{CC}	16	P	5V Power Supply Positive Terminal Connection

(1) Signal Types: I = Input, O = Output, I/O = Input or Output, P = Power, GND = Ground.

5 Specifications

5.1 Absolute Maximum Ratings

over operating free-air temperature range (unless otherwise noted) ⁽¹⁾

		MIN	MAX	UNIT
V_{CC}	Supply voltage (see Note ⁽²⁾)		7	V
V_I	Input voltage		7	V
	Off-state output voltage		6	V
	Continuous total dissipation	See Dissipation Rating Table		
T_{stg}	Storage temperature range	–65	150	°C
	Lead temperature 1,6 mm (1/16 inch) from case for 10 seconds		260	°C

- (1) Stresses beyond those listed under “absolute maximum ratings” may cause permanent damage to the device. These are stress ratings only, and functional operation of the device at these or any other conditions beyond those indicated under “recommended operating conditions” is not implied. Exposure to absolute-maximum-rated conditions for extended periods may affect device reliability.
- (2) All voltage values except differential output voltage, V_{OD} , are with respect to network ground terminal.

5.2 Dissipation Rating Table

PACKAGE	$T_A \leq 25^\circ\text{C}$ POWER RATING	DERATING FACTOR ABOVE $T_A = 25^\circ\text{C}$	$T_A = 70^\circ\text{C}$ POWER RATING	$T_A = 125^\circ\text{C}$ POWER RATING
D	950 mW	7.6 mW/°C	608 mW	N/A
N	1150 mW	9.2 mW/°C	736 mW	N/A

5.3 Recommended Operating Conditions

	MIN	NOM	MAX	UNIT
Supply voltage, V_{CC}	4.75	5	5.25	V
High level input voltage, V_{IH}	2			V
Low-level input voltage, V_{IL}			0.8	V
High-level output current, I_{OH}			–20	mA
Low-level output current, I_{OL}			20	mA
Operating free-air temperature, T_A	0		70	°C

5.4 Thermal Information

THERMAL METRIC ⁽¹⁾		D (SOIC)	NS (SOP)	UNIT
		16-PINS		
$R_{\theta JA}$	Junction-to-ambient thermal resistance	84.6	88.5	°C/W
$R_{\theta JC(top)}$	Junction-to-case (top) thermal resistance	43.5	46.2	°C/W
$R_{\theta JB}$	Junction-to-board thermal resistance	43.	50.	°C/W
Ψ_{JT}	Junction-to-top characterization parameter	10.4	13.5	°C/W
Ψ_{JB}	Junction-to-board characterization parameter	42.8	50.3	°C/W
$R_{\theta JC(bot)}$	Junction-to-case (bottom) thermal resistance	N/A	N/A	°C/W

- (1) For more information about traditional and new thermal metrics, see the [Semiconductor and IC package thermal metrics](#) application report.

5.5 Electrical Characteristics

over recommended operating free-air temperature range (unless otherwise noted)

PARAMETER		TEST CONDITIONS ⁽¹⁾		MIN	TYP ⁽²⁾	MAX	UNIT
V _{IK}	Input clamp voltage	V _{CC} = MIN,	I _I = -18mA			-1.5	V
V _{OH}	High-level output voltage	V _{CC} = MIN,	I _{OH} = -20mA	2.5			V
V _{OL}	Low-level output voltage	V _{CC} = MIN,	I _{OL} = 20mA			0.5	V
V _O	Output voltage	V _{CC} = MAX,	I _O = 0	0	6		V
V _{OD1}	Differential output voltage	V _{CC} = MIN,	I _O = 0	1.5	6		V
V _{OD2}	Differential output voltage	R _L = 100Ω,	See Figure 6-1	1/2 V _{OD1} or 2 ⁽³⁾			V
Δ V _{OD}	Change in magnitude of differential output voltage ⁽⁴⁾	R _L = 100Ω,	See Figure 6-1			±0.2	V
V _{OC}	Common-mode output voltage ⁽⁵⁾	R _L = 100Ω,	See Figure 6-1			±3	V
Δ V _{OC}	Change in magnitude of common-mode output voltage ⁽⁴⁾	R _L = 100Ω,	See Figure 6-1			±0.2	V
I _O	Output current with power off	V _{CC} = 0	V _O = 6V			100	
			V _O = -0.25V			-100	μA
I _{OZ}	Off state (high impedance state) output current	V _{CC} = MAX	V _O = 0.5V			-20	
			V _O = 2.5V			20	μA
I _I	Input current at maximum input voltage	V _{CC} = MAX,	V _I = 7V			100	μA
I _{IH}	High-level input current	V _{CC} = MAX,	V _I = 2.7V			20	μA
I _{IL}	Low-level input current	V _{CC} = MAX,	V _I = 0.4V			-200	μA
I _{OS}	Short-circuit output current ⁽⁶⁾	V _{CC} = MAX		-30	-150		mA
I _{CC}	Supply current (all drivers)	V _{CC} = MAX,	All outputs disabled	26		45	mA

- (1) For conditions shown as MIN or MAX, use the appropriate value specified under recommended operating conditions.
- (2) All typical values are at V_{CC} = 5 V and T_A = 25°C.
- (3) The minimum V_{OD2} with a 100-Ω load is either 1/2 V_{OD1} or 2 V, whichever is greater.
- (4) |V_{OD}| and |V_{OC}| are the changes in magnitude of V_{OD} and V_{OC}, respectively, that occur when the input is changed from a high level to a low level.
- (5) In ANSI Standard EIA/TIA-422-B, V_{OC}, which is the average of the two output voltages with respect to ground, is called output offset voltage, V_{OS}.
- (6) Not more than one output should be shorted at a time, and duration of the short circuit should not exceed one second.

5.6 Switching Characteristics

V_{CC} = 5 V, T_A = 25°C (see Figure 6-2)

PARAMETER		TEST CONDITIONS		MIN	TYP	MAX	UNIT
t _{PLH}	Propagation delay time, low-to-high-level output	S1 and S2 open,	C _L = 30 pF		6	13	ns
t _{PHL}	Propagation delay time, high-to-low-level output	S1 and S2 open,	C _L = 30 pF		9	14	ns
	Output-to-output skew	S1 and S2 open,	C _L = 30 pF		3	6	ns
t _{PZH}	Output enable time to high level	S1 open and S2 closed			11	15	ns
t _{PZL}	Output enable time to low level	S1 closed and S2 open			16	20	ns
t _{PHZ}	Output disable time from high level	S1 open and S2 closed,	C _L = 10 pF		8	15	ns
t _{PLZ}	Output disable time from low level	S1 and S2 closed,	C _L = 10 pF		18	20	ns

5.7 Typical Characteristics†

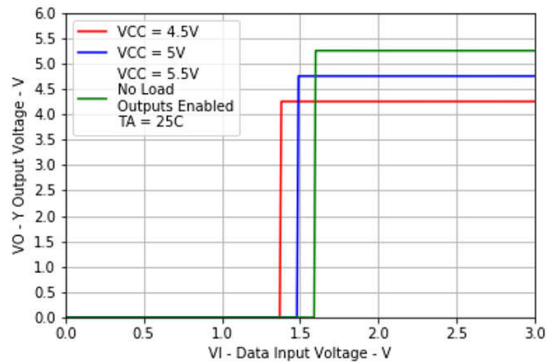

Figure 5-1. Y Output Voltage vs Data Input Voltage

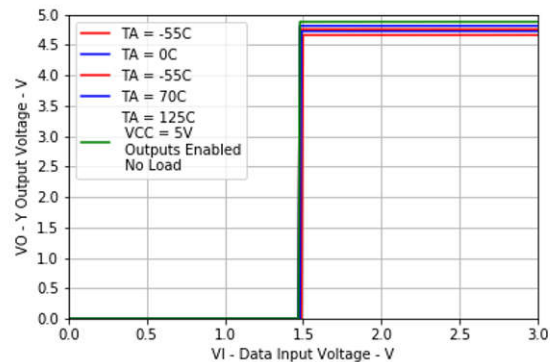
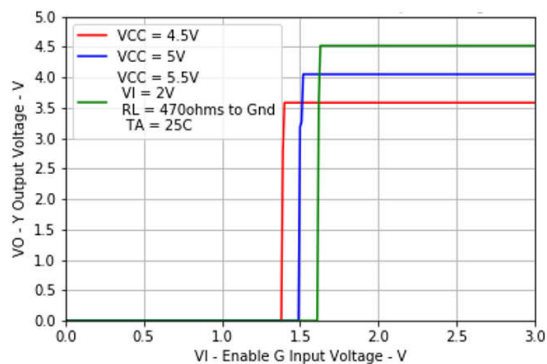
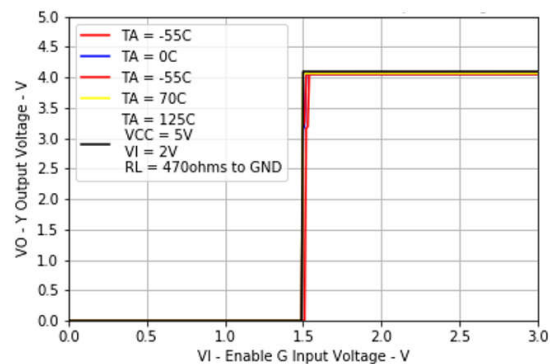

Figure 5-2. Y Output Voltage vs Data Input Voltage



The A input is connected to V_{CC} during the testing of the Y outputs and to ground during the testing of the Z outputs.

Figure 5-3. Y Output Voltage vs Enable G Input Voltage



The A input is connected to V_{CC} during the testing of the Y outputs and to ground during the testing of the Z outputs.

Figure 5-4. Y Output Voltage vs Enable G Input Voltage

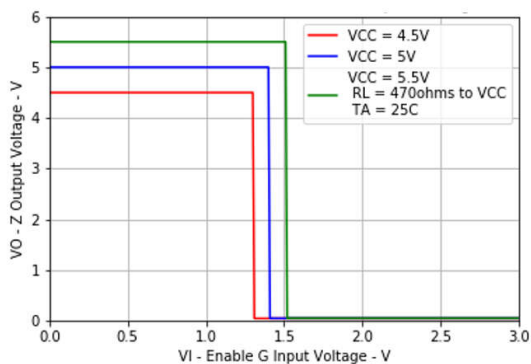

The A input is connected to V_{CC} during the testing of the Y outputs and to ground during the testing of the Z outputs.

Figure 5-5. Z Output Voltage vs Enable G Input Voltage

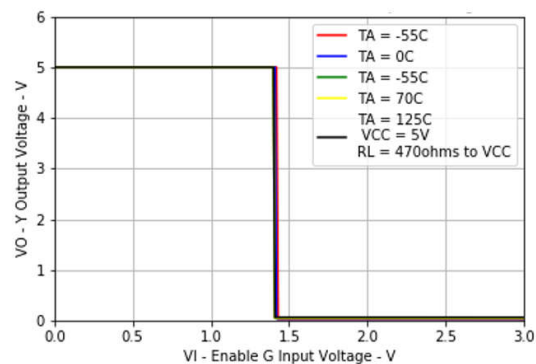

The A input is connected to GND during the testing of the Y outputs and to V_{CC} during the testing of the Z outputs.

Figure 5-6. Z Output Voltage vs Enable G Input Voltage

† Operation of the device at these or any other conditions beyond those indicated under “recommended operating conditions” is not implied.

5.7 Typical Characteristics† (continued)

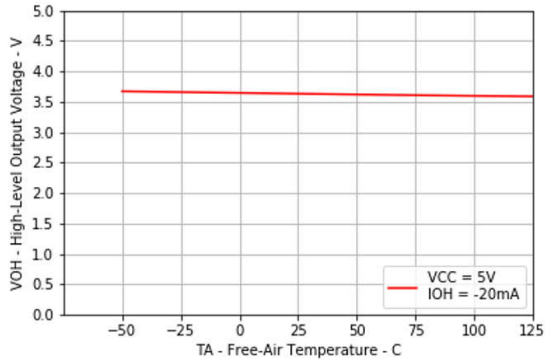

The A input is connected to V_{CC} during the testing of the Y outputs and to ground during the testing of the Z outputs.
Figure 5-7. High-level Output Voltage vs Free-air Temperature

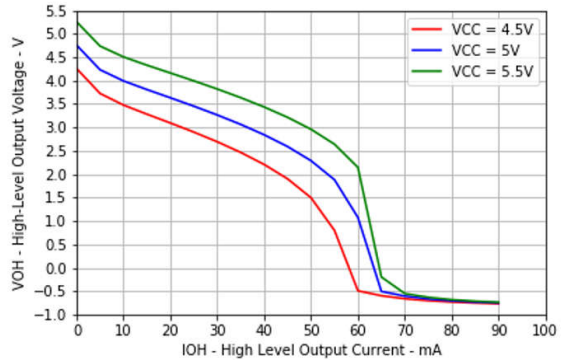

The A input is connected to V_{CC} during the testing of the Y outputs and to ground during the testing of the Z outputs.
Figure 5-8. High-level Output Voltage vs Output Current

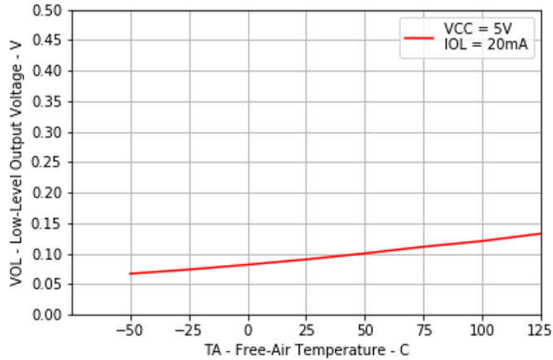

The A input is connected to GND during the testing of the Y outputs and to V_{CC} during the testing of the Z outputs.
Figure 5-9. Low-level Output Voltage vs Free-air Temperature

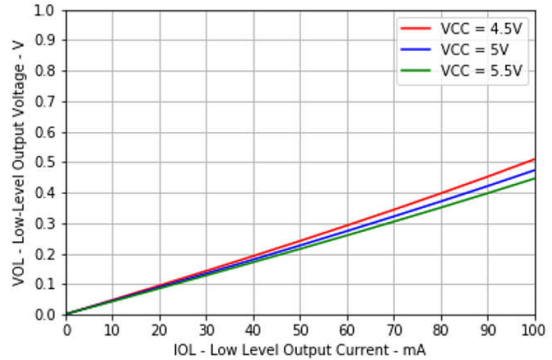

The A input is connected to GND during the testing of the Y outputs and to V_{CC} during the testing of the Z outputs.
Figure 5-10. Low-level Output Voltage vs Low-level Output Current

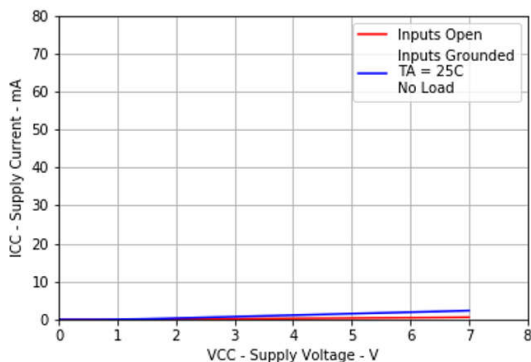

Figure 5-11. Supply Current vs Supply Voltage

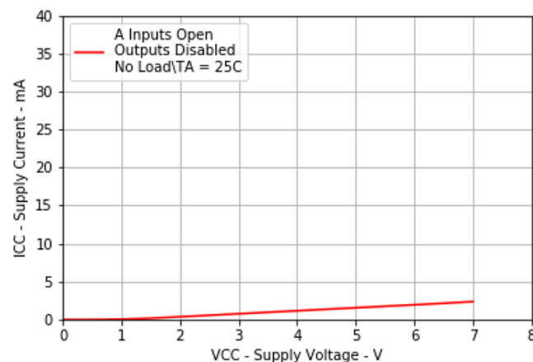

Figure 5-12. Supply Current vs Supply Voltage

† Operation of the device at these or any other conditions beyond those indicated under “recommended operating conditions” is not implied.

5.7 Typical Characteristics[†] (continued)

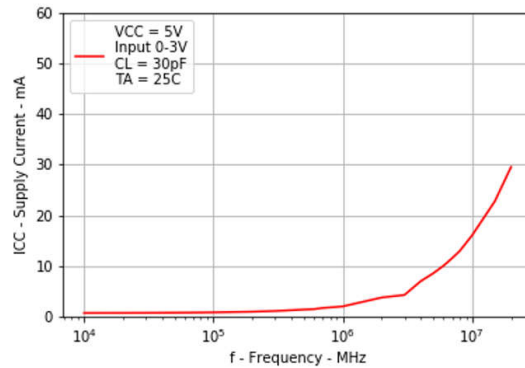

Figure 5-13. Supply Current vs Frequency

[†] Operation of the device at these or any other conditions beyond those indicated under “recommended operating conditions” is not implied.

[†] Operation of the device at these or any other conditions beyond those indicated under “recommended operating conditions” is not implied.

[†] Operation of the device at these or any other conditions beyond those indicated under “recommended operating conditions” is not implied.

6 Parameter Measurement Information

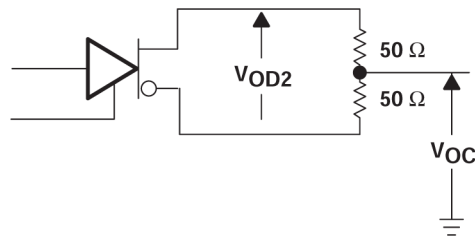
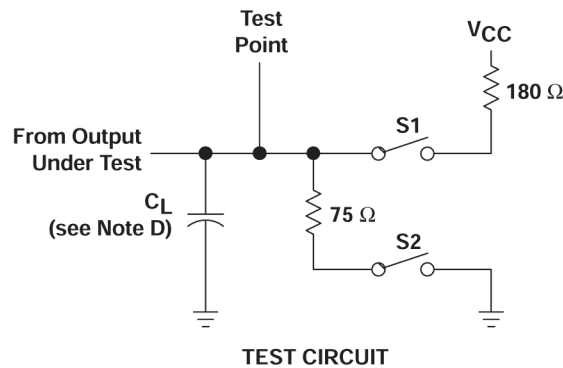
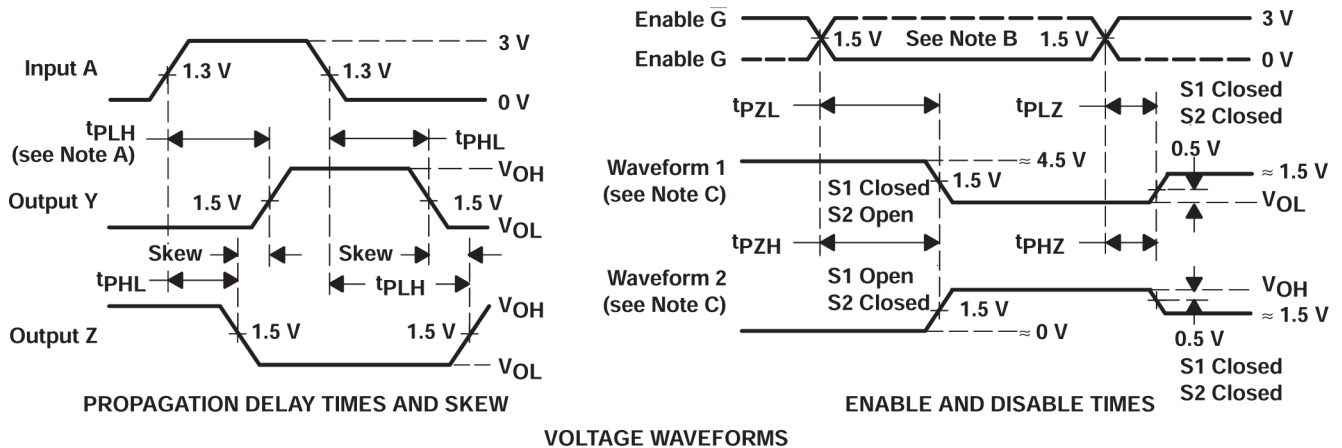

Figure 6-1. Differential and Common-Mode Output Voltages



- When measuring propagation delay times and skew, switches S1 and S2 are open.
- Each enable is tested separately.
- Waveform 1 is for an output with internal conditions such that the output is low except when disabled by the output control. Waveform 2 is for an output with internal conditions such that the output is high except when disabled by the output control.
- C_L includes probe and jig capacitance.
- All input pulses are supplied by generators having the following characteristics: $PRR \leq 1$ MHz, $Z_O \approx 50 \Omega$, $t_r \leq 15$ ns, and $t_f \leq 6$ ns.

Figure 6-2. Test Circuit and Voltage Waveforms

7 Device Functional Modes

Table 7-1. Function Table (Each Driver)

INPUT ⁽¹⁾	ENABLES		OUTPUTS	
	A	G	\bar{G}	Y
H	H	X	H	L
L	H	X	L	H
H	X	L	H	L
L	X	L	L	H
X	L	H	Z	Z

(1) H = high level, L = low level, X = irrelevant, Z = high impedance (off)

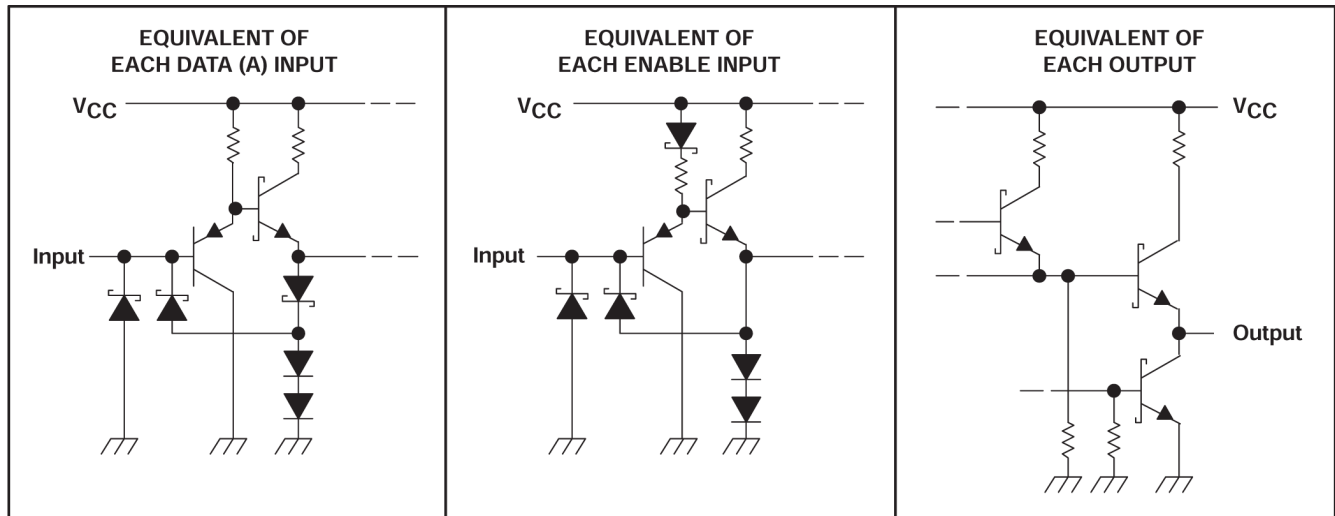

Figure 7-1. Schematics of Inputs and Outputs

8 Device and Documentation Support

TI offers an extensive line of development tools. Tools and software to evaluate the performance of the device, generate code, and develop solutions are listed below.

8.1 Receiving Notification of Documentation Updates

To receive notification of documentation updates, navigate to the device product folder on ti.com. Click on *Notifications* to register and receive a weekly digest of any product information that has changed. For change details, review the revision history included in any revised document.

8.2 Support Resources

[TI E2E™ support forums](#) are an engineer's go-to source for fast, verified answers and design help — straight from the experts. Search existing answers or ask your own question to get the quick design help you need.

Linked content is provided "AS IS" by the respective contributors. They do not constitute TI specifications and do not necessarily reflect TI's views; see TI's [Terms of Use](#).

8.3 Trademarks

TI E2E™ is a trademark of Texas Instruments.
All trademarks are the property of their respective owners.

8.4 Electrostatic Discharge Caution



This integrated circuit can be damaged by ESD. Texas Instruments recommends that all integrated circuits be handled with appropriate precautions. Failure to observe proper handling and installation procedures can cause damage.

ESD damage can range from subtle performance degradation to complete device failure. Precision integrated circuits may be more susceptible to damage because very small parametric changes could cause the device not to meet its published specifications.

8.5 Glossary

[TI Glossary](#) This glossary lists and explains terms, acronyms, and definitions.

9 Revision History

NOTE: Page numbers for previous revisions may differ from page numbers in the current version.

Changes from Revision D (April 1998) to Revision E (March 2024)	Page
• Changed the numbering format for tables, figures, and cross-references throughout the document.....	1

10 Mechanical, Packaging, and Orderable Information

The following pages include mechanical, packaging, and orderable information. This information is the most current data available for the designated devices. This data is subject to change without notice and revision of this document. For browser-based versions of this data sheet, refer to the left-hand navigation.

PACKAGING INFORMATION

Orderable Device	Status (1)	Package Type	Package Drawing	Pins	Package Qty	Eco Plan (2)	Lead finish/ Ball material (6)	MSL Peak Temp (3)	Op Temp (°C)	Device Marking (4/5)	Samples
SN75ALS192DR	ACTIVE	SOIC	D	16	2500	RoHS & Green	NIPDAU	Level-1-260C-UNLIM	0 to 70	75ALS192	Samples
SN75ALS192N	ACTIVE	PDIP	N	16	25	RoHS & Green	NIPDAU	N / A for Pkg Type	0 to 70	SN75ALS192N	Samples
SN75ALS192NE4	ACTIVE	PDIP	N	16	25	RoHS & Green	NIPDAU	N / A for Pkg Type	0 to 70	SN75ALS192N	Samples
SN75ALS192NSR	ACTIVE	SO	NS	16	2000	RoHS & Green	NIPDAU	Level-1-260C-UNLIM	0 to 70	75ALS192	Samples

(1) The marketing status values are defined as follows:

ACTIVE: Product device recommended for new designs.

LIFEBUY: TI has announced that the device will be discontinued, and a lifetime-buy period is in effect.

NRND: Not recommended for new designs. Device is in production to support existing customers, but TI does not recommend using this part in a new design.

PREVIEW: Device has been announced but is not in production. Samples may or may not be available.

OBSELETE: TI has discontinued the production of the device.

(2) **RoHS:** TI defines "RoHS" to mean semiconductor products that are compliant with the current EU RoHS requirements for all 10 RoHS substances, including the requirement that RoHS substance do not exceed 0.1% by weight in homogeneous materials. Where designed to be soldered at high temperatures, "RoHS" products are suitable for use in specified lead-free processes. TI may reference these types of products as "Pb-Free".

RoHS Exempt: TI defines "RoHS Exempt" to mean products that contain lead but are compliant with EU RoHS pursuant to a specific EU RoHS exemption.

Green: TI defines "Green" to mean the content of Chlorine (Cl) and Bromine (Br) based flame retardants meet JS709B low halogen requirements of <=1000ppm threshold. Antimony trioxide based flame retardants must also meet the <=1000ppm threshold requirement.

(3) MSL, Peak Temp. - The Moisture Sensitivity Level rating according to the JEDEC industry standard classifications, and peak solder temperature.

(4) There may be additional marking, which relates to the logo, the lot trace code information, or the environmental category on the device.

(5) Multiple Device Markings will be inside parentheses. Only one Device Marking contained in parentheses and separated by a "-" will appear on a device. If a line is indented then it is a continuation of the previous line and the two combined represent the entire Device Marking for that device.

(6) Lead finish/Ball material - Orderable Devices may have multiple material finish options. Finish options are separated by a vertical ruled line. Lead finish/Ball material values may wrap to two lines if the finish value exceeds the maximum column width.

Important Information and Disclaimer:The information provided on this page represents TI's knowledge and belief as of the date that it is provided. TI bases its knowledge and belief on information provided by third parties, and makes no representation or warranty as to the accuracy of such information. Efforts are underway to better integrate information from third parties. TI has taken and

continues to take reasonable steps to provide representative and accurate information but may not have conducted destructive testing or chemical analysis on incoming materials and chemicals. TI and TI suppliers consider certain information to be proprietary, and thus CAS numbers and other limited information may not be available for release.

In no event shall TI's liability arising out of such information exceed the total purchase price of the TI part(s) at issue in this document sold by TI to Customer on an annual basis.

TAPE AND REEL INFORMATION



QUADRANT ASSIGNMENTS FOR PIN 1 ORIENTATION IN TAPE



*All dimensions are nominal

Device	Package Type	Package Drawing	Pins	SPQ	Reel Diameter (mm)	Reel Width W1 (mm)	A0 (mm)	B0 (mm)	K0 (mm)	P1 (mm)	W (mm)	Pin1 Quadrant
SN75ALS192DR	SOIC	D	16	2500	330.0	16.4	6.5	10.3	2.1	8.0	16.0	Q1
SN75ALS192NSR	SO	NS	16	2000	330.0	16.4	8.2	10.5	2.5	12.0	16.0	Q1

TAPE AND REEL BOX DIMENSIONS



*All dimensions are nominal

Device	Package Type	Package Drawing	Pins	SPQ	Length (mm)	Width (mm)	Height (mm)
SN75ALS192DR	SOIC	D	16	2500	340.5	336.1	32.0
SN75ALS192NSR	SO	NS	16	2000	356.0	356.0	35.0

TUBE

*All dimensions are nominal

Device	Package Name	Package Type	Pins	SPQ	L (mm)	W (mm)	T (μm)	B (mm)
SN75ALS192D	D	SOIC	16	40	507	8	3940	4.32
SN75ALS192N	N	PDIP	16	25	506	13.97	11230	4.32
SN75ALS192NE4	N	PDIP	16	25	506	13.97	11230	4.32



PACKAGE OUTLINE

NS0016A

SOP - 2.00 mm max height

SOP

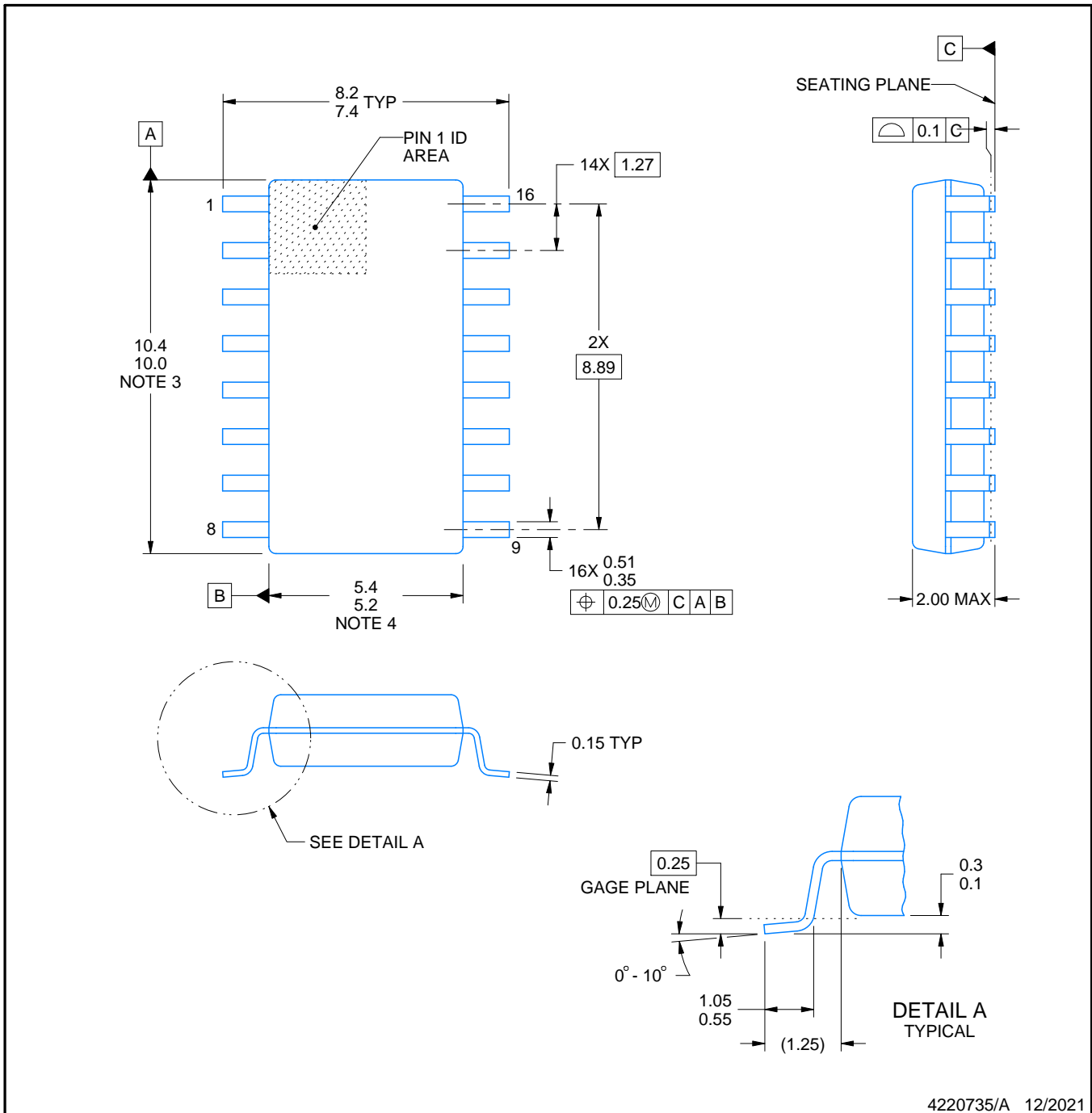

NOTES:

1. All linear dimensions are in millimeters. Dimensions in parenthesis are for reference only. Dimensioning and tolerancing per ASME Y14.5M.
2. This drawing is subject to change without notice.
3. This dimension does not include mold flash, protrusions, or gate burrs. Mold flash, protrusions, or gate burrs shall not exceed 0.15 mm, per side.
4. This dimension does not include interlead flash. Interlead flash shall not exceed 0.25 mm, per side.

EXAMPLE BOARD LAYOUT

NS0016A

SOP - 2.00 mm max height

SOP

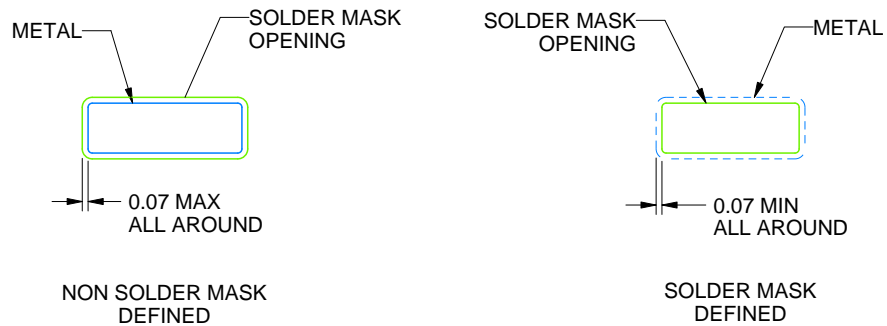

4220735/A 12/2021

NOTES: (continued)

5. Publication IPC-7351 may have alternate designs.

6. Solder mask tolerances between and around signal pads can vary based on board fabrication site.

EXAMPLE STENCIL DESIGN

NS0016A

SOP - 2.00 mm max height

SOP

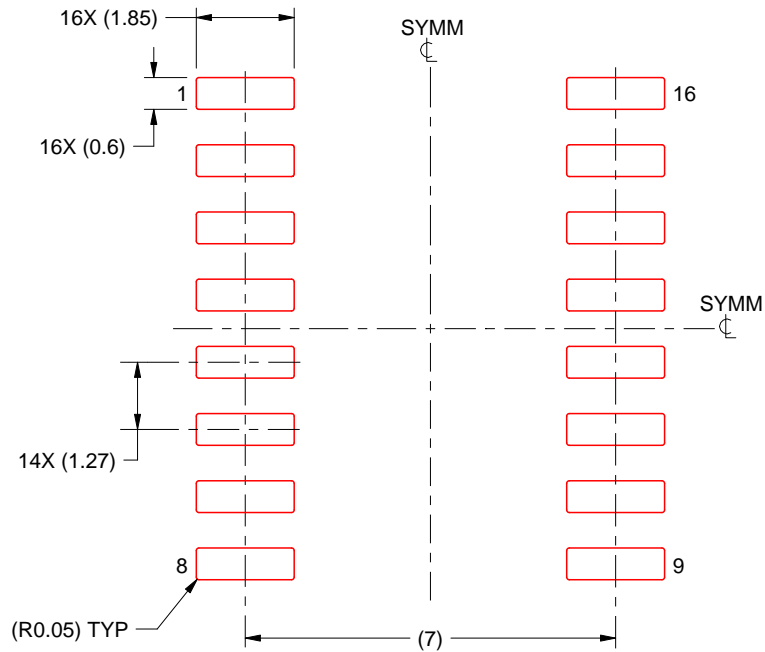

SOLDER PASTE EXAMPLE
BASED ON 0.125 mm THICK STENCIL
SCALE:7X

4220735/A 12/2021

NOTES: (continued)

7. Laser cutting apertures with trapezoidal walls and rounded corners may offer better paste release. IPC-7525 may have alternate design recommendations.
8. Board assembly site may have different recommendations for stencil design.

D (R-PDSO-G16)

PLASTIC SMALL OUTLINE



- NOTES:
- A. All linear dimensions are in inches (millimeters).
 - B. This drawing is subject to change without notice.
 - C. Body length does not include mold flash, protrusions, or gate burrs. Mold flash, protrusions, or gate burrs shall not exceed 0.006 (0,15) each side.
 - D. Body width does not include interlead flash. Interlead flash shall not exceed 0.017 (0,43) each side.
 - E. Reference JEDEC MS-012 variation AC.

MECHANICAL DATA

NS (R-PDSO-G**)

PLASTIC SMALL-OUTLINE PACKAGE

14-PINS SHOWN



- NOTES:
- A. All linear dimensions are in millimeters.
 - B. This drawing is subject to change without notice.
 - C. Body dimensions do not include mold flash or protrusion, not to exceed 0,15.

N (R-PDIP-T**)

PLASTIC DUAL-IN-LINE PACKAGE

16 PINS SHOWN



- NOTES:
- A. All linear dimensions are in inches (millimeters).
 - B. This drawing is subject to change without notice.
 - Falls within JEDEC MS-001, except 18 and 20 pin minimum body length (Dim A).
 - The 20 pin end lead shoulder width is a vendor option, either half or full width.

IMPORTANT NOTICE AND DISCLAIMER

TI PROVIDES TECHNICAL AND RELIABILITY DATA (INCLUDING DATA SHEETS), DESIGN RESOURCES (INCLUDING REFERENCE DESIGNS), APPLICATION OR OTHER DESIGN ADVICE, WEB TOOLS, SAFETY INFORMATION, AND OTHER RESOURCES "AS IS" AND WITH ALL FAULTS, AND DISCLAIMS ALL WARRANTIES, EXPRESS AND IMPLIED, INCLUDING WITHOUT LIMITATION ANY IMPLIED WARRANTIES OF MERCHANTABILITY, FITNESS FOR A PARTICULAR PURPOSE OR NON-INFRINGEMENT OF THIRD PARTY INTELLECTUAL PROPERTY RIGHTS.

These resources are intended for skilled developers designing with TI products. You are solely responsible for (1) selecting the appropriate TI products for your application, (2) designing, validating and testing your application, and (3) ensuring your application meets applicable standards, and any other safety, security, regulatory or other requirements.

These resources are subject to change without notice. TI grants you permission to use these resources only for development of an application that uses the TI products described in the resource. Other reproduction and display of these resources is prohibited. No license is granted to any other TI intellectual property right or to any third party intellectual property right. TI disclaims responsibility for, and you will fully indemnify TI and its representatives against, any claims, damages, costs, losses, and liabilities arising out of your use of these resources.

TI's products are provided subject to [TI's Terms of Sale](#) or other applicable terms available either on [ti.com](https://www.ti.com) or provided in conjunction with such TI products. TI's provision of these resources does not expand or otherwise alter TI's applicable warranties or warranty disclaimers for TI products.

TI objects to and rejects any additional or different terms you may have proposed.

Mailing Address: Texas Instruments, Post Office Box 655303, Dallas, Texas 75265
Copyright © 2024, Texas Instruments Incorporated