

TMUX7212M 44 V, Low-RON, 1:1 (SPST), 4-Channel Precision Switches with Latch-Up Immunity and 1.8-V Logic

1 Features

- [Latch-up immune](#)
- Dual supply range: $\pm 4.5\text{V}$ to $\pm 22\text{V}$
- Single supply range: 4.5V to 44 V
- -55°C to $+125^\circ\text{C}$ operating temperature
- Low on-resistance: 2Ω
- High current support: 220mA (maximum)
- [1.8V logic compatible](#)
- [Integrated pull-down resistor on logic pins](#)
- [Fail-safe logic](#)
- [Rail-to-rail operation](#)
- [Bidirectional operation](#)

2 Applications

- [Avionics flight control unit](#)
- [Aircraft cockpit display](#)
- [Standalone avionics precision flight control](#)
- [Interconnect distribution box](#)
- [Aerospace and defense](#)

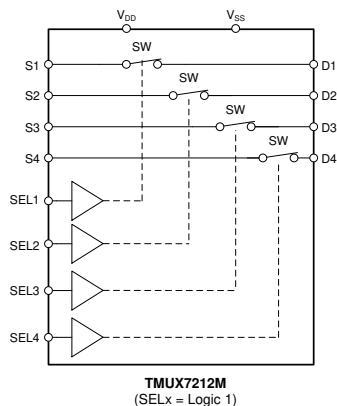

TMUX7212M Block Diagrams

3 Description

The TMUX7212M is a complementary metal-oxide semiconductor (CMOS) switch with four independently selectable 1:1, single-pole, single-throw (SPST) switch channels. The devices work with a single supply (4.5V to 44 V), dual supplies ($\pm 4.5\text{V}$ to $\pm 22\text{V}$), or asymmetric supplies (such as $V_{DD} = 12\text{V}$, $V_{SS} = -5\text{V}$). The TMUX7212M supports bidirectional analog and digital signals on the source (Sx) and drain (Dx) pins ranging from V_{SS} to V_{DD} .

Each switch of the TMUX7212M is controlled with appropriate logic control inputs on the SELx pins. The TMUX7212M is part of the precision switches and multiplexers family of devices and have very low on and off leakage currents allowing them to be used in high precision measurement applications.

The TMUX7212M provides latch-up immunity, preventing undesirable high current events between parasitic structures within the device typically caused by overvoltage events. A latch-up condition typically continues until the power supply rails are turned off and can lead to device failure. The latch-up immunity feature allows the TMUX7212M family of switches and multiplexers to be used in harsh environments. Additionally, the TMUX7212M is rated for extended temperature use down to -55°C , making it an excellent choice for harsh industrial and aerospace applications.

Package Information

PART NUMBER ⁽¹⁾	PACKAGE ⁽²⁾	PACKAGE SIZE ⁽³⁾
TMUX7212M	PW (TSSOP, 16)	5 mm × 6.4 mm

- (1) See [Section 4](#)
- (2) For more information, see [Section 12](#)
- (3) The package size (length × width) is a nominal value and includes pins, where applicable.



Table of Contents

1 Features	1	7.8 Off Isolation.....	22
2 Applications	1	7.9 Channel-to-Channel Crosstalk.....	23
3 Description	1	7.10 Bandwidth.....	23
4 Device Comparison Table	2	7.11 THD + Noise.....	24
5 Pin Configuration and Functions	3	7.12 Power Supply Rejection Ratio (PSRR).....	24
6 Specifications	4	8 Detailed Description	25
6.1 Absolute Maximum Ratings.....	4	8.1 Overview.....	25
6.2 ESD Ratings.....	4	8.2 Functional Block Diagram.....	25
6.3 Thermal Information.....	5	8.3 Feature Description.....	25
6.4 Recommended Operating Conditions.....	5	8.4 Device Functional Modes.....	27
6.5 Source or Drain Continuous Current.....	5	8.5 Truth Tables.....	27
±15 V Dual Supply: Electrical Characteristics.....	6	9 Application and Implementation	28
±15 V Dual Supply: Switching Characteristics.....	7	9.1 Application Information.....	28
±20 V Dual Supply: Electrical Characteristics.....	8	9.2 Typical Application – Switched Gain Amplifier.....	28
±20 V Dual Supply: Switching Characteristics.....	9	9.3 Design Requirements.....	28
44 V Single Supply: Electrical Characteristics.....	10	9.4 Detailed Design Procedure.....	29
44 V Single Supply: Switching Characteristics.....	11	9.5 Power Supply Recommendations.....	29
12 V Single Supply: Electrical Characteristics.....	12	9.6 Layout.....	30
12 V Single Supply: Switching Characteristics.....	13	10 Device and Documentation Support	31
6.6 Typical Characteristics.....	14	10.1 Documentation Support.....	31
7 Parameter Measurement Information	19	10.2 Receiving Notification of Documentation Updates.....	31
7.1 On-Resistance.....	19	10.3 Support Resources.....	31
7.2 Off-Leakage Current.....	19	10.4 Trademarks.....	31
7.3 On-Leakage Current.....	20	10.5 Electrostatic Discharge Caution.....	31
7.4 t_{ON} and t_{OFF} Time.....	20	10.6 Glossary.....	31
7.5 $t_{ON(VDD)}$ Time.....	21	11 Revision History	31
7.6 Propagation Delay.....	21	12 Mechanical, Packaging, and Orderable Information	31
7.7 Charge Injection.....	22		

4 Device Comparison Table

PRODUCT	DESCRIPTION
TMUX7212M	Low-Leakage-Current, Precision, 4-Channel, 1:1 (SPST) Switches (Logic High)

5 Pin Configuration and Functions

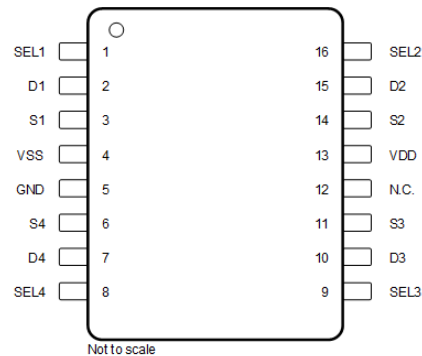

Figure 5-1. PW Package 16-Pin TSSOP (Top View)

Table 5-1. Pin Functions

PIN		TYPE ⁽¹⁾	DESCRIPTION ⁽²⁾
NAME	NO.		
D1	2	I/O	Drain pin 1. Can be an input or output.
D2	15	I/O	Drain pin 2. Can be an input or output.
D3	10	I/O	Drain pin 3. Can be an input or output.
D4	7	I/O	Drain pin 4. Can be an input or output.
GND	5	P	Ground (0V) reference
N.C.	12	—	No internal connection. Can be shorted to GND or left floating.
S1	3	I/O	Source pin 1. Can be an input or output.
S2	14	I/O	Source pin 2. Can be an input or output.
S3	11	I/O	Source pin 3. Can be an input or output.
S4	6	I/O	Source pin 4. Can be an input or output.
SEL1	1	I	Logic control input 1, has internal 4M Ω pull-down resistor. Controls channel 1 state as shown in Section 8.5 .
SEL2	16	I	Logic control input 2, has internal 4M Ω pull-down resistor. Controls channel 2 state as shown in Section 8.5 .
SEL3	9	I	Logic control input 3, has internal 4M Ω pull-down resistor. Controls channel 3 state as shown in Section 8.5 .
SEL4	8	I	Logic control input 4, has internal 4M Ω pull-down resistor. Controls channel 4 state as shown in Section 8.5 .
VDD	13	P	Positive power supply. This pin is the most positive power-supply potential. For reliable operation, connect a decoupling capacitor ranging from 0.1 μ F to 10 μ F between V _{DD} and GND.
VSS	4	P	Negative power supply. This pin is the most negative power-supply potential. In single-supply applications, this pin can be connected to ground. For reliable operation, connect a decoupling capacitor ranging from 0.1 μ F to 10 μ F between V _{SS} and GND.

(1) I = input, O = output, I/O = input and output, P = power.

(2) Refer to [Section 8.4](#) for what to do with unused pins.

6 Specifications

6.1 Absolute Maximum Ratings

over operating free-air temperature range (unless otherwise noted)^{(1) (2)}

		MIN	MAX	UNIT
$V_{DD} - V_{SS}$	Supply voltage		48	V
V_{DD}		-0.5	48	V
V_{SS}		-48	0.5	V
V_{SEL} or V_{EN}	Logic control input pin voltage (SELx)	-0.5	48	V
I_{SEL} or I_{EN}	Logic control input pin current (SELx)	-30	30	mA
V_S or V_D	Source or drain voltage (Sx, Dx)	$V_{SS}-0.5$	$V_{DD}+0.5$	V
I_{IK}	Diode clamp current ⁽³⁾	-30	30	mA
I_S or I_D (CONT)	Source or drain continuous current (Sx, Dx)		$I_{DC} + 10\%$ ⁽⁴⁾	mA
T_A	Ambient temperature	-55	150	°C
T_{stg}	Storage temperature	-65	150	°C
T_J	Junction temperature		150	°C
P_{tot}	Total power dissipation (QFN) ⁽⁵⁾		1650	mW
	Total power dissipation (TSSOP) ⁽⁵⁾		700	mW

- (1) Operation outside the *Absolute Maximum Rating* may cause permanent device damage. *Absolute Maximum Rating* do not imply functional operation of the device at these or any other conditions beyond those listed under *Recommended Operating Condition*. If used outside the *Recommended Operating Condition* but within the *Absolute Maximum Rating*, the device may not be fully functional, and this may affect device reliability, functionality, performance, and shorten the device lifetime.
- (2) All voltages are with respect to ground, unless otherwise specified.
- (3) Pins are diode-clamped to the power-supply rails. Over voltage signals must be voltage and current limited to maximum ratings.
- (4) Refer to *Source or Drain Continuous Current* table for I_{DC} specifications.
- (5) For QFN package: P_{tot} derates linearly above $T_A = 70^\circ\text{C}$ by $24.2\text{mW}/^\circ\text{C}$.
For TSSOP package: $P_{tot} = 700\text{ mW}$ (max) and derates linearly above $T_A = 70^\circ\text{C}$ by $10.7\text{mW}/^\circ\text{C}$.

6.2 ESD Ratings

		VALUE	UNIT
TMUX7212			
$V_{(ESD)}$	Electrostatic discharge	Human body model (HBM), per ANSI/ESDA/ JEDEC JS-001, all pins ⁽¹⁾	±1500
		Charged device model (CDM), per JEDEC JS-002, all pins ⁽²⁾	±500

- (1) JEDEC document JEP155 states that 500-V HBM allows safe manufacturing with a standard ESD control process.
- (2) JEDEC document JEP157 states that 250-V CDM allows safe manufacturing with a standard ESD control process.

6.3 Thermal Information

THERMAL METRIC ⁽¹⁾		TMUX7212	UNIT
		PW (TSSOP)	
		16 PINS	
$R_{\theta JA}$	Junction-to-ambient thermal resistance	94.5	°C/W
$R_{\theta JC(top)}$	Junction-to-case (top) thermal resistance	25.5	°C/W
$R_{\theta JB}$	Junction-to-board thermal resistance	41.1	°C/W
Ψ_{JT}	Junction-to-top characterization parameter	1.1	°C/W
Ψ_{JB}	Junction-to-board characterization parameter	40.4	°C/W
$R_{\theta JC(bot)}$	Junction-to-case (bottom) thermal resistance	N/A	°C/W

(1) For more information about traditional and new thermal metrics, see the [Semiconductor and IC Package Thermal Metrics](#) application report.

6.4 Recommended Operating Conditions

over operating free-air temperature range (unless otherwise noted)

		MIN	NOM	MAX	UNIT
$V_{DD} - V_{SS}$ ⁽¹⁾	Power supply voltage differential	4.5		44	V
V_{DD}	Positive power supply voltage	4.5		44	V
V_S or V_D	Signal path input/output voltage (source or drain pin) (Sx, D)	V_{SS}		V_{DD}	V
V_{SEL} or V_{EN}	Address or enable pin voltage	0		44	V
I_S or $I_D (CONT)$	Source or drain continuous current (Sx, D)			I_{DC} ⁽²⁾	mA
T_A	Ambient temperature	-55		125	°C

(1) V_{DD} and V_{SS} can be any value as long as $4.5V \leq (V_{DD} - V_{SS}) \leq 44V$, and the minimum V_{DD} is met.

(2) Refer to *Source or Drain Continuous Current* table for I_{DC} specifications.

6.5 Source or Drain Continuous Current

at supply voltage of $V_{DD} \pm 10\%$, $V_{SS} \pm 10\%$ (unless otherwise noted)

CONTINUOUS CURRENT PER CHANNEL (I_{DC}) ⁽²⁾		$T_A = 25^\circ\text{C}$	$T_A = 85^\circ\text{C}$	$T_A = 125^\circ\text{C}$	UNIT
PACKAGE	TEST CONDITIONS				
PW (TSSOP)	+44 V Dual Supply ⁽¹⁾	220	160	100	mA
	±15 V Dual Supply	220	160	100	mA
	+12 V Single Supply	190	130	90	mA
	±5V Dual Supply	170	120	80	mA
	+5V Single Supply	130	90	60	mA

(1) Specified for nominal supply voltage only.

(2) Refer to Total power dissipation (P_{tot}) limits in *Absolute Maximum Ratings* table that must be followed with maximum continuous current specification.

±15 V Dual Supply: Electrical Characteristics

$V_{DD} = +15\text{ V} \pm 10\%$, $V_{SS} = -15\text{ V} \pm 10\%$, GND = 0V (unless otherwise noted)

Typical at $V_{DD} = +15\text{ V}$, $V_{SS} = -15\text{ V}$, $T_A = 25^\circ\text{C}$ (unless otherwise noted)

PARAMETER		TEST CONDITIONS	T_A	MIN	TYP	MAX	UNIT	
ANALOG SWITCH								
R_{ON}	On-resistance	$V_S = -10\text{ V to } +10\text{ V}$ $I_D = -10\text{ mA}$ Refer to On-Resistance	25°C		2	2.7	Ω	
			-40°C to +85°C			3.4	Ω	
			-55°C to +125°C			4	Ω	
ΔR_{ON}	On-resistance mismatch between channels	$V_S = -10\text{ V to } +10\text{ V}$ $I_D = -10\text{ mA}$ Refer to On-Resistance	25°C		0.1	0.18	Ω	
			-40°C to +85°C			0.19	Ω	
			-55°C to +125°C			0.21	Ω	
$R_{ON\text{ FLAT}}$	On-resistance flatness	$V_S = -10\text{ V to } +10\text{ V}$ $I_S = -10\text{ mA}$ Refer to On-Resistance	25°C		0.2	0.46	Ω	
			-40°C to +85°C			0.65	Ω	
			-55°C to +125°C			0.7	Ω	
$R_{ON\text{ DRIFT}}$	On-resistance drift	$V_S = 0\text{ V}$, $I_S = -10\text{ mA}$ Refer to On-Resistance	-55°C to +125°C		0.008		$\Omega/^\circ\text{C}$	
$I_{S(OFF)}$	Source off leakage current ⁽¹⁾	$V_{DD} = 16.5\text{ V}$, $V_{SS} = -16.5\text{ V}$ Switch state is off $V_S = +10\text{ V} / -10\text{ V}$ $V_D = -10\text{ V} / +10\text{ V}$ Refer to Off-Leakage Current	25°C	-0.25	0.05	0.25	nA	
			-40°C to +85°C		-3		3	nA
			-55°C to +125°C		-20		20	nA
$I_{D(OFF)}$	Drain off leakage current ⁽¹⁾	$V_{DD} = 16.5\text{ V}$, $V_{SS} = -16.5\text{ V}$ Switch state is off $V_S = +10\text{ V} / -10\text{ V}$ $V_D = -10\text{ V} / +10\text{ V}$ Refer to Off-Leakage Current	25°C	-0.25	0.05	0.25	nA	
			-40°C to +85°C		-3		3	nA
			-55°C to +125°C		-20		20	nA
$I_{S(ON)}$ $I_{D(ON)}$	Channel on leakage current ⁽²⁾	$V_{DD} = 16.5\text{ V}$, $V_{SS} = -16.5\text{ V}$ Switch state is on $V_S = V_D = \pm 10\text{ V}$ Refer to On-Leakage Current	25°C	-0.4	0.1	0.4	nA	
			-40°C to +85°C		-1		1	nA
			-55°C to +125°C		-3		3	nA
LOGIC INPUTS (SEL / EN pins)								
V_{IH}	Logic voltage high		-55°C to +125°C	1.3		44	V	
V_{IL}	Logic voltage low		-55°C to +125°C	0		0.8	V	
I_{IH}	Input leakage current		-55°C to +125°C		0.4	1.2	μA	
I_{IL}	Input leakage current		-55°C to +125°C	-0.1	-0.005		μA	
C_{IN}	Logic input capacitance		-55°C to +125°C		3.5		pF	
POWER SUPPLY								
I_{DD}	V_{DD} supply current	$V_{DD} = 16.5\text{ V}$, $V_{SS} = -16.5\text{ V}$ Logic inputs = 0V, 5V, or V_{DD}	25°C		35	56	μA	
			-40°C to +85°C			65	μA	
			-55°C to +125°C			80	μA	
I_{SS}	V_{SS} supply current	$V_{DD} = 16.5\text{ V}$, $V_{SS} = -16.5\text{ V}$ Logic inputs = 0V, 5V, or V_{DD}	25°C		5	20	μA	
			-40°C to +85°C			24	μA	
			-55°C to +125°C			35	μA	

(1) When V_S is positive, V_D is negative, or when V_S is negative, V_D is positive.

(2) When V_S is at a voltage potential, V_D is floating, or when V_D is at a voltage potential, V_S is floating.

±15 V Dual Supply: Switching Characteristics

 $V_{DD} = +15\text{ V} \pm 10\%$, $V_{SS} = -15\text{ V} \pm 10\%$, GND = 0V (unless otherwise noted)

 Typical at $V_{DD} = +15\text{ V}$, $V_{SS} = -15\text{ V}$, $T_A = 25^\circ\text{C}$ (unless otherwise noted)

PARAMETER		TEST CONDITIONS	T_A	MIN	TYP	MAX	UNIT
t_{ON}	Turn-on time from control input	$V_S = 10\text{ V}$ $R_L = 300\ \Omega$, $C_L = 35\text{ pF}$ Refer to Turn-on and Turn-off Time	25°C		100	175	ns
			-40°C to +85°C			205	ns
			-55°C to +125°C			225	ns
t_{OFF}	Turn-off time from control input	$V_S = 10\text{ V}$ $R_L = 300\ \Omega$, $C_L = 35\text{ pF}$ Refer to Turn-on and Turn-off Time	25°C		80	205	ns
			-40°C to +85°C			225	ns
			-55°C to +125°C			240	ns
$t_{ON(VDD)}$	Device turn on time (V_{DD} to output)	V_{DD} rise time = 1 μs $R_L = 300\ \Omega$, $C_L = 35\text{ pF}$ Refer to Turn-on (VDD) Time	25°C		0.17		ms
			-40°C to +85°C			0.18	ms
			-55°C to +125°C			0.18	ms
t_{PD}	Propagation delay	$R_L = 50\ \Omega$, $C_L = 5\text{ pF}$ Refer to Propagation Delay	25°C		260		ps
Q_{INJ}	Charge injection	$V_S = 0\text{ V}$, $C_L = 100\text{ pF}$ Refer to Charge Injection	25°C		60		pC
O_{ISO}	Off-isolation	$R_L = 50\ \Omega$, $C_L = 5\text{ pF}$ $V_S = 0\text{ V}$, $f = 100\text{ kHz}$ Refer to Off Isolation	25°C		-70		dB
O_{ISO}	Off-isolation	$R_L = 50\ \Omega$, $C_L = 5\text{ pF}$ $V_S = 0\text{ V}$, $f = 1\text{ MHz}$ Refer to Off Isolation	25°C		-50		dB
X_{TALK}	Crosstalk	$R_L = 50\ \Omega$, $C_L = 5\text{ pF}$ $V_S = 0\text{ V}$, $f = 100\text{ kHz}$ Refer to Crosstalk	25°C		-114		dB
X_{TALK}	Crosstalk	$R_L = 50\ \Omega$, $C_L = 5\text{ pF}$ $V_S = 0\text{ V}$, $f = 1\text{ MHz}$ Refer to Crosstalk	25°C		-93		dB
BW	-3dB Bandwidth	$R_L = 50\ \Omega$, $C_L = 5\text{ pF}$ $V_S = 0\text{ V}$ Refer to Bandwidth	25°C		56		MHz
I_L	Insertion loss	$R_L = 50\ \Omega$, $C_L = 5\text{ pF}$ $V_S = 0\text{ V}$, $f = 1\text{ MHz}$	25°C		-0.15		dB
ACPSRR	AC Power Supply Rejection Ratio	$V_{PP} = 0.62\text{ V}$ on V_{DD} and V_{SS} $R_L = 50\ \Omega$, $C_L = 5\text{ pF}$, $f = 1\text{ MHz}$ Refer to ACPSRR	25°C		-68		dB
THD+N	Total Harmonic Distortion + Noise	$V_{PP} = 15\text{ V}$, $V_{BIAS} = 0\text{ V}$ $R_L = 10\text{ k}\Omega$, $C_L = 5\text{ pF}$, $f = 20\text{ Hz}$ to 20 kHz Refer to THD + Noise	25°C		0.0004		%
$C_{S(OFF)}$	Source off capacitance	$V_S = 0\text{ V}$, $f = 1\text{ MHz}$	25°C		28		pF
$C_{D(OFF)}$	Drain off capacitance	$V_S = 0\text{ V}$, $f = 1\text{ MHz}$	25°C		45		pF
$C_{S(ON)}$, $C_{D(ON)}$	On capacitance	$V_S = 0\text{ V}$, $f = 1\text{ MHz}$	25°C		145		pF

±20 V Dual Supply: Electrical Characteristics

$V_{DD} = +20\text{ V} \pm 10\%$, $V_{SS} = -20\text{ V} \pm 10\%$, GND = 0V (unless otherwise noted)

Typical at $V_{DD} = +20\text{ V}$, $V_{SS} = -20\text{ V}$, $T_A = 25^\circ\text{C}$ (unless otherwise noted)

PARAMETER		TEST CONDITIONS	T_A	MIN	TYP	MAX	UNIT
ANALOG SWITCH							
R_{ON}	On-resistance	$V_S = -15\text{ V to } +15\text{ V}$ $I_D = -10\text{ mA}$ Refer to On-Resistance	25°C	1.7	2.5		Ω
			-40°C to +85°C			3	Ω
			-55°C to +125°C			3.6	Ω
ΔR_{ON}	On-resistance mismatch between channels	$V_S = -15\text{ V to } +15\text{ V}$ $I_D = -10\text{ mA}$ Refer to On-Resistance	25°C	0.1	0.18		Ω
			-40°C to +85°C			0.19	Ω
			-55°C to +125°C			0.21	Ω
$R_{ON\ FLAT}$	On-resistance flatness	$V_S = -15\text{ V to } +15\text{ V}$ $I_S = -10\text{ mA}$ Refer to On-Resistance	25°C	0.3	0.6		Ω
			-40°C to +85°C			0.8	Ω
			-55°C to +125°C			0.95	Ω
$R_{ON\ DRIFT}$	On-resistance drift	$V_S = 0\text{ V}$, $I_S = -10\text{ mA}$ Refer to On-Resistance	-55°C to +125°C	0.008			$\Omega/^\circ\text{C}$
$I_{S(OFF)}$	Source off leakage current ⁽¹⁾	$V_{DD} = 22\text{ V}$, $V_{SS} = -22\text{ V}$ Switch state is off $V_S = +15\text{ V} / -15\text{ V}$ $V_D = -15\text{ V} / +15\text{ V}$ Refer to Off-Leakage Current	25°C	-1	0.05	1	nA
			-40°C to +85°C	-4.5		4.5	nA
			-55°C to +125°C	-33		33	nA
$I_{D(OFF)}$	Drain off leakage current ⁽¹⁾	$V_{DD} = 22\text{ V}$, $V_{SS} = -22\text{ V}$ Switch state is off $V_S = +15\text{ V} / -15\text{ V}$ $V_D = -15\text{ V} / +15\text{ V}$ Refer to Off-Leakage Current	25°C	-1	0.1	1	nA
			-40°C to +85°C	-4.5		4.5	nA
			-55°C to +125°C	-33		33	nA
$I_{S(ON)}$ $I_{D(ON)}$	Channel on leakage current ⁽²⁾	$V_{DD} = 22\text{ V}$, $V_{SS} = -22\text{ V}$ Switch state is on $V_S = V_D = \pm 15\text{ V}$ Refer to On-Leakage Current	25°C	-1	0.1	1	nA
			-40°C to +85°C	-1.5		1.5	nA
			-55°C to +125°C	-8		8	nA
LOGIC INPUTS (SEL / EN pins)							
V_{IH}	Logic voltage high		-55°C to +125°C	1.3		44	V
V_{IL}	Logic voltage low		-55°C to +125°C	0		0.8	V
I_{IH}	Input leakage current		-55°C to +125°C		0.4	1.2	μA
I_{IL}	Input leakage current		-55°C to +125°C	-0.1	-0.005		μA
C_{IN}	Logic input capacitance		-55°C to +125°C		3.5		pF
POWER SUPPLY							
I_{DD}	V_{DD} supply current	$V_{DD} = 22\text{ V}$, $V_{SS} = -22\text{ V}$ Logic inputs = 0V, 5V, or V_{DD}	25°C	33	65		μA
			-40°C to +85°C			74	μA
			-55°C to +125°C			90	μA
I_{SS}	V_{SS} supply current	$V_{DD} = 22\text{ V}$, $V_{SS} = -22\text{ V}$ Logic inputs = 0V, 5V, or V_{DD}	25°C	7	26		μA
			-40°C to +85°C			30	μA
			-55°C to +125°C			45	μA

(1) When V_S is positive, V_D is negative, or when V_S is negative, V_D is positive.

(2) When V_S is at a voltage potential, V_D is floating, or when V_D is at a voltage potential, V_S is floating.

±20 V Dual Supply: Switching Characteristics

$V_{DD} = +20\text{ V} \pm 10\%$, $V_{SS} = -20\text{ V} \pm 10\%$, $GND = 0\text{ V}$ (unless otherwise noted)

Typical at $V_{DD} = +20\text{ V}$, $V_{SS} = -20\text{ V}$, $T_A = 25^\circ\text{C}$ (unless otherwise noted)

PARAMETER		TEST CONDITIONS	T_A	MIN	TYP	MAX	UNIT
t_{ON}	Turn-on time from control input	$V_S = 10\text{ V}$ $R_L = 300\ \Omega$, $C_L = 35\text{ pF}$ Refer to Turn-on and Turn-off Time	25°C		100	185	ns
			-40°C to +85°C			210	ns
			-55°C to +125°C			230	ns
t_{OFF}	Turn-off time from control input	$V_S = 10\text{ V}$ $R_L = 300\ \Omega$, $C_L = 35\text{ pF}$ Refer to Turn-on and Turn-off Time	25°C		90	210	ns
			-40°C to +85°C			225	ns
			-55°C to +125°C			235	ns
$t_{ON(VDD)}$	Device turn on time (V_{DD} to output)	V_{DD} rise time = 1 μs $R_L = 300\ \Omega$, $C_L = 35\text{ pF}$ Refer to Turn-on (VDD) Time	25°C		0.17		ms
			-40°C to +85°C			0.18	ms
			-55°C to +125°C			0.18	ms
t_{PD}	Propagation delay	$R_L = 50\ \Omega$, $C_L = 5\text{ pF}$ Refer to Propagation Delay	25°C		260		ps
Q_{INJ}	Charge injection	$V_S = 0\text{ V}$, $C_L = 100\text{ pF}$ Refer to Charge Injection	25°C		92		pC
O_{ISO}	Off-isolation	$R_L = 50\ \Omega$, $C_L = 5\text{ pF}$ $V_S = 0\text{ V}$, $f = 100\text{ kHz}$ Refer to Off Isolation	25°C		-70		dB
O_{ISO}	Off-isolation	$R_L = 50\ \Omega$, $C_L = 5\text{ pF}$ $V_S = 0\text{ V}$, $f = 1\text{ MHz}$ Refer to Off Isolation	25°C		-50		dB
X_{TALK}	Crosstalk	$R_L = 50\ \Omega$, $C_L = 5\text{ pF}$ $V_S = 0\text{ V}$, $f = 100\text{ kHz}$ Refer to Crosstalk	25°C		-112		dB
X_{TALK}	Crosstalk	$R_L = 50\ \Omega$, $C_L = 5\text{ pF}$ $V_S = 0\text{ V}$, $f = 1\text{ MHz}$ Refer to Crosstalk	25°C		-93		dB
BW	-3dB Bandwidth	$R_L = 50\ \Omega$, $C_L = 5\text{ pF}$ $V_S = 0\text{ V}$ Refer to Bandwidth	25°C		48		MHz
I_L	Insertion loss	$R_L = 50\ \Omega$, $C_L = 5\text{ pF}$ $V_S = 0\text{ V}$, $f = 1\text{ MHz}$	25°C		-0.14		dB
ACPSRR	AC Power Supply Rejection Ratio	$V_{PP} = 0.62\text{ V}$ on V_{DD} and V_{SS} $R_L = 50\ \Omega$, $C_L = 5\text{ pF}$, $f = 1\text{ MHz}$ Refer to ACPSRR	25°C		-68		dB
THD+N	Total Harmonic Distortion + Noise	$V_{PP} = 20\text{ V}$, $V_{BIAS} = 0\text{ V}$ $R_L = 10\text{ k}\Omega$, $C_L = 5\text{ pF}$, $f = 20\text{ Hz}$ to 20 kHz Refer to THD + Noise	25°C		0.0003		%
$C_{S(OFF)}$	Source off capacitance	$V_S = 0\text{ V}$, $f = 1\text{ MHz}$	25°C		28		pF
$C_{D(OFF)}$	Drain off capacitance	$V_S = 0\text{ V}$, $f = 1\text{ MHz}$	25°C		45		pF
$C_{S(ON)}$, $C_{D(ON)}$	On capacitance	$V_S = 0\text{ V}$, $f = 1\text{ MHz}$	25°C		145		pF

44 V Single Supply: Electrical Characteristics

$V_{DD} = +44\text{ V}$, $V_{SS} = 0\text{ V}$, $GND = 0\text{ V}$ (unless otherwise noted)

Typical at $V_{DD} = +44\text{ V}$, $V_{SS} = 0\text{ V}$, $T_A = 25^\circ\text{C}$ (unless otherwise noted)

PARAMETER		TEST CONDITIONS	T_A	MIN	TYP	MAX	UNIT	
ANALOG SWITCH								
R_{ON}	On-resistance	$V_S = 0\text{ V to } 40\text{ V}$ $I_D = -10\text{ mA}$ Refer to On-Resistance	25°C		2	2.4	Ω	
			-40°C to +85°C			3.2	Ω	
			-55°C to +125°C			3.8	Ω	
ΔR_{ON}	On-resistance mismatch between channels	$V_S = 0\text{ V to } 40\text{ V}$ $I_D = -10\text{ mA}$ Refer to On-Resistance	25°C		0.1	0.18	Ω	
			-40°C to +85°C			0.19	Ω	
			-55°C to +125°C			0.21	Ω	
$R_{ON\ FLAT}$	On-resistance flatness	$V_S = 0\text{ V to } 40\text{ V}$ $I_D = -10\text{ mA}$ Refer to On-Resistance	25°C		0.65	0.8	Ω	
			-40°C to +85°C			1.1	Ω	
			-55°C to +125°C			1.2	Ω	
$R_{ON\ DRIFT}$	On-resistance drift	$V_S = 22\text{ V}$, $I_S = -10\text{ mA}$ Refer to On-Resistance	-55°C to +125°C		0.007		$\Omega/^\circ\text{C}$	
$I_{S(OFF)}$	Source off leakage current ⁽¹⁾	$V_{DD} = 44\text{ V}$, $V_{SS} = 0\text{ V}$ Switch state is off $V_S = 40\text{ V} / 1\text{ V}$ $V_D = 1\text{ V} / 40\text{ V}$ Refer to Off-Leakage Current	25°C	-1	0.05	1	nA	
			-40°C to +85°C		-7		7	nA
			-55°C to +125°C		-50		50	nA
$I_{D(OFF)}$	Drain off leakage current ⁽¹⁾	$V_{DD} = 44\text{ V}$, $V_{SS} = 0\text{ V}$ Switch state is off $V_S = 40\text{ V} / 1\text{ V}$ $V_D = 1\text{ V} / 40\text{ V}$ Refer to Off-Leakage Current	25°C	-1	0.05	1	nA	
			-40°C to +85°C		-7		7	nA
			-55°C to +125°C		-50		50	nA
$I_{S(ON)}$ $I_{D(ON)}$	Channel on leakage current ⁽²⁾	$V_{DD} = 44\text{ V}$, $V_{SS} = 0\text{ V}$ Switch state is on $V_S = V_D = 40\text{ V}$ or 1 V Refer to On-Leakage Current	25°C	-1	0.05	1	nA	
			-40°C to +85°C		-3.5		3.5	nA
			-55°C to +125°C		-5		5	nA
LOGIC INPUTS (SEL / EN pins)								
V_{IH}	Logic voltage high		-55°C to +125°C		1.3	44	V	
V_{IL}	Logic voltage low		-55°C to +125°C		0	0.8	V	
I_{IH}	Input leakage current		-55°C to +125°C		0.6	1.2	μA	
I_{IL}	Input leakage current		-55°C to +125°C	-0.1	-0.005		μA	
C_{IN}	Logic input capacitance		-55°C to +125°C		3.5		pF	
POWER SUPPLY								
I_{DD}	V_{DD} supply current	$V_{DD} = 44\text{ V}$, $V_{SS} = 0\text{ V}$ Logic inputs = 0V, 5V, or V_{DD}	25°C		44	79	μA	
			-40°C to +85°C			88	μA	
			-55°C to +125°C			105	μA	

(1) When V_S is positive, V_D is negative, or when V_S is negative, V_D is positive.

(2) When V_S is at a voltage potential, V_D is floating, or when V_D is at a voltage potential, V_S is floating.

44 V Single Supply: Switching Characteristics

$V_{DD} = +44\text{ V}$, $V_{SS} = 0\text{ V}$, $GND = 0\text{ V}$ (unless otherwise noted)

Typical at $V_{DD} = +44\text{ V}$, $V_{SS} = 0\text{ V}$, $T_A = 25^\circ\text{C}$ (unless otherwise noted)

PARAMETER		TEST CONDITIONS	T_A	MIN	TYP	MAX	UNIT
t_{ON}	Turn-on time from control input	$V_S = 18\text{ V}$ $R_L = 300\ \Omega$, $C_L = 35\text{ pF}$ Refer to Turn-on and Turn-off Time	25°C		80	185	ns
			-40°C to +85°C			205	ns
			-55°C to +125°C			225	ns
t_{OFF}	Turn-off time from control input	$V_S = 18\text{ V}$ $R_L = 300\ \Omega$, $C_L = 35\text{ pF}$ Refer to Turn-on and Turn-off Time	25°C		90	205	ns
			-40°C to +85°C			220	ns
			-55°C to +125°C			228	ns
$t_{ON(VDD)}$	Device turn on time (V_{DD} to output)	V_{DD} rise time = 1 μs $R_L = 300\ \Omega$, $C_L = 35\text{ pF}$ Refer to Turn-on (VDD) Time	25°C		0.14		ms
			-40°C to +85°C			0.15	ms
			-55°C to +125°C			0.15	ms
t_{PD}	Propagation delay	$R_L = 50\ \Omega$, $C_L = 5\text{ pF}$ Refer to Propagation Delay	25°C		270		ps
Q_{INJ}	Charge injection	$V_S = 22\text{ V}$, $C_L = 100\text{ pF}$ Refer to Charge Injection	25°C		104		pC
O_{ISO}	Off-isolation	$R_L = 50\ \Omega$, $C_L = 5\text{ pF}$ $V_S = 6\text{ V}$, $f = 100\text{ kHz}$ Refer to Off Isolation	25°C		-70		dB
O_{ISO}	Off-isolation	$R_L = 50\ \Omega$, $C_L = 5\text{ pF}$ $V_S = 6\text{ V}$, $f = 1\text{ MHz}$ Refer to Off Isolation	25°C		-50		dB
X_{TALK}	Crosstalk	$R_L = 50\ \Omega$, $C_L = 5\text{ pF}$ $V_S = 6\text{ V}$, $f = 100\text{ kHz}$ Refer to Crosstalk	25°C		-112		dB
X_{TALK}	Crosstalk	$R_L = 50\ \Omega$, $C_L = 5\text{ pF}$ $V_S = 6\text{ V}$, $f = 1\text{ MHz}$ Refer to Crosstalk	25°C		-93		dB
BW	-3dB Bandwidth	$R_L = 50\ \Omega$, $C_L = 5\text{ pF}$ $V_S = 6\text{ V}$ Refer to Bandwidth	25°C		46		MHz
I_L	Insertion loss	$R_L = 50\ \Omega$, $C_L = 5\text{ pF}$ $V_S = 6\text{ V}$, $f = 1\text{ MHz}$	25°C		-0.15		dB
ACPSRR	AC Power Supply Rejection Ratio	$V_{PP} = 0.62\text{ V}$ on V_{DD} and V_{SS} $R_L = 50\ \Omega$, $C_L = 5\text{ pF}$, $f = 1\text{ MHz}$ Refer to ACPSRR	25°C		-66		dB
THD+N	Total Harmonic Distortion + Noise	$V_{PP} = 22\text{ V}$, $V_{BIAS} = 22\text{ V}$ $R_L = 10\text{ k}\Omega$, $C_L = 5\text{ pF}$, $f = 20\text{ Hz}$ to 20 kHz Refer to THD + Noise	25°C		0.0003		%
$C_{S(OFF)}$	Source off capacitance	$V_S = 22\text{ V}$, $f = 1\text{ MHz}$	25°C		28		pF
$C_{D(OFF)}$	Drain off capacitance	$V_S = 22\text{ V}$, $f = 1\text{ MHz}$	25°C		45		pF
$C_{S(ON)}$, $C_{D(ON)}$	On capacitance	$V_S = 22\text{ V}$, $f = 1\text{ MHz}$	25°C		145		pF

12 V Single Supply: Electrical Characteristics

$V_{DD} = +12\text{ V} \pm 10\%$, $V_{SS} = 0\text{ V}$, $GND = 0\text{ V}$ (unless otherwise noted)

Typical at $V_{DD} = +12\text{ V}$, $V_{SS} = 0\text{ V}$, $T_A = 25^\circ\text{C}$ (unless otherwise noted)

PARAMETER		TEST CONDITIONS	T_A	MIN	TYP	MAX	UNIT	
ANALOG SWITCH								
R_{ON}	On-resistance	$V_S = 0\text{ V to }10\text{ V}$ $I_D = -10\text{ mA}$ Refer to On-Resistance	25°C		2.8	5.4	Ω	
			-40°C to +85°C			6.8	Ω	
			-55°C to +125°C			7.4	Ω	
ΔR_{ON}	On-resistance mismatch between channels	$V_S = 0\text{ V to }10\text{ V}$ $I_D = -10\text{ mA}$ Refer to On-Resistance	25°C		0.13	0.21	Ω	
			-40°C to +85°C			0.23	Ω	
			-55°C to +125°C			0.25	Ω	
$R_{ON\ FLAT}$	On-resistance flatness	$V_S = 0\text{ V to }10\text{ V}$ $I_S = -10\text{ mA}$ Refer to On-Resistance	25°C		1	1.7	Ω	
			-40°C to +85°C			1.9	Ω	
			-55°C to +125°C			2	Ω	
$R_{ON\ DRIFT}$	On-resistance drift	$V_S = 6\text{ V}$, $I_S = -10\text{ mA}$ Refer to On-Resistance	-55°C to +125°C		0.015		$\Omega/^\circ\text{C}$	
$I_{S(OFF)}$	Source off leakage current ⁽¹⁾	$V_{DD} = 13.2\text{ V}$, $V_{SS} = 0\text{ V}$ Switch state is off $V_S = 10\text{ V} / 1\text{ V}$ $V_D = 1\text{ V} / 10\text{ V}$ Refer to Off-Leakage Current	25°C	-0.25	0.01	0.25	nA	
			-40°C to +85°C		-2		2	nA
			-55°C to +125°C		-16		16	nA
$I_{D(OFF)}$	Drain off leakage current ⁽¹⁾	$V_{DD} = 13.2\text{ V}$, $V_{SS} = 0\text{ V}$ Switch state is off $V_S = 10\text{ V} / 1\text{ V}$ $V_D = 1\text{ V} / 10\text{ V}$ Refer to Off-Leakage Current	25°C	-0.25	0.05	0.25	nA	
			-40°C to +85°C		-2		2	nA
			-55°C to +125°C		-16		16	nA
$I_{S(ON)}$ $I_{D(ON)}$	Channel on leakage current ⁽²⁾	$V_{DD} = 13.2\text{ V}$, $V_{SS} = 0\text{ V}$ Switch state is on $V_S = V_D = 10\text{ V or }1\text{ V}$ Refer to On-Leakage Current	25°C	-0.5	0.05	0.5	nA	
			-40°C to +85°C		-1		1	nA
			-55°C to +125°C		-3		3	nA
LOGIC INPUTS (SEL / EN pins)								
V_{IH}	Logic voltage high		-55°C to +125°C		1.3	44	V	
V_{IL}	Logic voltage low		-55°C to +125°C		0	0.8	V	
I_{IH}	Input leakage current		-55°C to +125°C		0.4	1.2	μA	
I_{IL}	Input leakage current		-55°C to +125°C	-0.1	-0.005		μA	
C_{IN}	Logic input capacitance		-55°C to +125°C		3.5		pF	
POWER SUPPLY								
I_{DD}	V_{DD} supply current	$V_{DD} = 13.2\text{ V}$, $V_{SS} = 0\text{ V}$ Logic inputs = 0V, 5V, or V_{DD}	25°C		30	44	μA	
			-40°C to +85°C			52	μA	
			-55°C to +125°C			62	μA	

(1) When V_S is positive, V_D is negative, or when V_S is negative, V_D is positive.

(2) When V_S is at a voltage potential, V_D is floating, or when V_D is at a voltage potential, V_S is floating.

12 V Single Supply: Switching Characteristics

 $V_{DD} = +12\text{ V} \pm 10\%$, $V_{SS} = 0\text{ V}$, $GND = 0\text{ V}$ (unless otherwise noted)

 Typical at $V_{DD} = +12\text{ V}$, $V_{SS} = 0\text{ V}$, $T_A = 25^\circ\text{C}$ (unless otherwise noted)

PARAMETER		TEST CONDITIONS	T_A	MIN	TYP	MAX	UNIT
t_{ON}	Turn-on time from control input	$V_S = 8\text{ V}$ $R_L = 300\ \Omega$, $C_L = 35\text{ pF}$ Refer to Turn-on and Turn-off Time	25°C		170	225	ns
			-40°C to +85°C			276	ns
			-55°C to +125°C			315	ns
t_{OFF}	Turn-off time from control input	$V_S = 8\text{ V}$ $R_L = 300\ \Omega$, $C_L = 35\text{ pF}$ Refer to Turn-on and Turn-off Time	25°C		75	248	ns
			-40°C to +85°C			285	ns
			-55°C to +125°C			310	ns
$t_{ON(VDD)}$	Device turn on time (V_{DD} to output)	V_{DD} rise time = 1 μs $R_L = 300\ \Omega$, $C_L = 35\text{ pF}$ Refer to Turn-on (VDD) Time	25°C		0.17		ms
			-40°C to +85°C			0.18	ms
			-55°C to +125°C			0.18	ms
t_{PD}	Propagation delay	$R_L = 50\ \Omega$, $C_L = 5\text{ pF}$ Refer to Propagation Delay	25°C		270		ps
Q_{INJ}	Charge injection	$V_S = 6\text{ V}$, $C_L = 100\text{ pF}$ Refer to Charge Injection	25°C		12		pC
O_{ISO}	Off-isolation	$R_L = 50\ \Omega$, $C_L = 5\text{ pF}$ $V_S = 6\text{ V}$, $f = 100\text{ kHz}$ Refer to Off Isolation	25°C		-70		dB
O_{ISO}	Off-isolation	$R_L = 50\ \Omega$, $C_L = 5\text{ pF}$ $V_S = 6\text{ V}$, $f = 1\text{ MHz}$ Refer to Off Isolation	25°C		-50		dB
X_{TALK}	Crosstalk	$R_L = 50\ \Omega$, $C_L = 5\text{ pF}$ $V_S = 6\text{ V}$, $f = 100\text{ kHz}$ Refer to Crosstalk	25°C		-112		dB
X_{TALK}	Crosstalk	$R_L = 50\ \Omega$, $C_L = 5\text{ pF}$ $V_S = 6\text{ V}$, $f = 1\text{ MHz}$ Refer to Crosstalk	25°C		-93		dB
BW	-3dB Bandwidth	$R_L = 50\ \Omega$, $C_L = 5\text{ pF}$ $V_S = 6\text{ V}$ Refer to Bandwidth	25°C		125		MHz
I_L	Insertion loss	$R_L = 50\ \Omega$, $C_L = 5\text{ pF}$ $V_S = 6\text{ V}$, $f = 1\text{ MHz}$	25°C		-0.25		dB
ACPSRR	AC Power Supply Rejection Ratio	$V_{PP} = 0.62\text{ V}$ on V_{DD} and V_{SS} $R_L = 50\ \Omega$, $C_L = 5\text{ pF}$, $f = 1\text{ MHz}$ Refer to ACPSRR	25°C		-70		dB
THD+N	Total Harmonic Distortion + Noise	$V_{PP} = 6\text{ V}$, $V_{BIAS} = 6\text{ V}$ $R_L = 10\text{ k}\Omega$, $C_L = 5\text{ pF}$, $f = 20\text{ Hz}$ to 20 kHz Refer to THD + Noise	25°C		0.001		%
$C_{S(OFF)}$	Source off capacitance	$V_S = 6\text{ V}$, $f = 1\text{ MHz}$	25°C		35		pF
$C_{D(OFF)}$	Drain off capacitance	$V_S = 6\text{ V}$, $f = 1\text{ MHz}$	25°C		50		pF
$C_{S(ON)}$, $C_{D(ON)}$	On capacitance	$V_S = 6\text{ V}$, $f = 1\text{ MHz}$	25°C		145		pF

6.6 Typical Characteristics

at $T_A = 25^\circ\text{C}$ (unless otherwise noted)

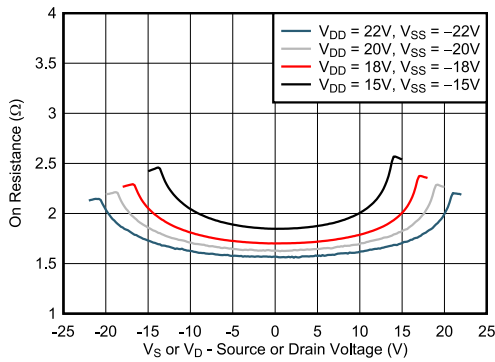

Figure 6-1. On-Resistance vs. Source or Drain Voltage – Dual Supply

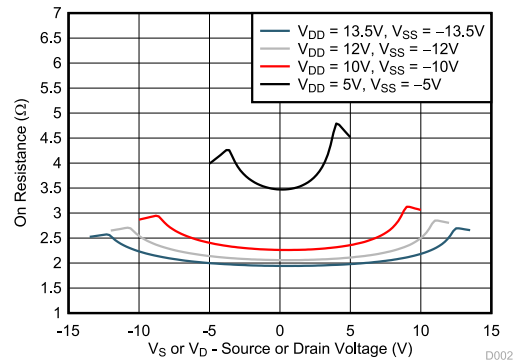

Figure 6-2. On-Resistance vs. Source or Drain Voltage – Dual Supply

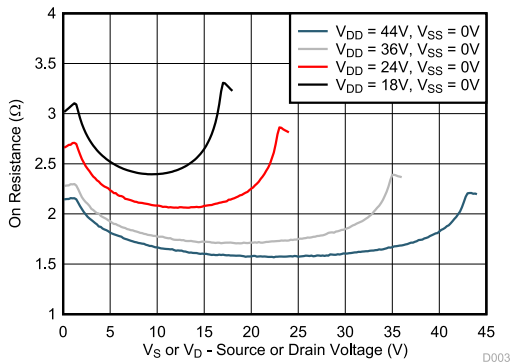

Figure 6-3. On-Resistance vs. Source or Drain Voltage – Single Supply

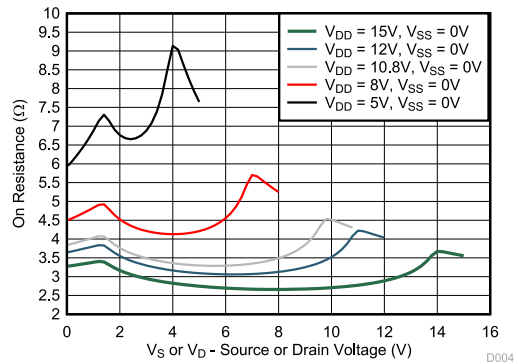

Figure 6-4. On-Resistance vs. Source or Drain Voltage – Single Supply

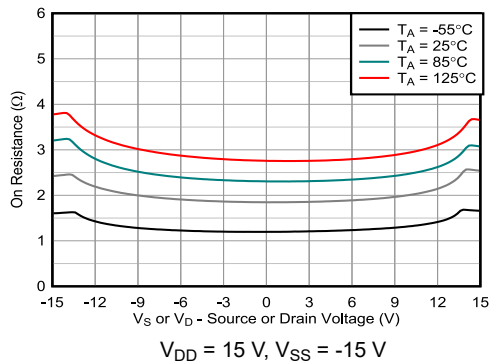

Figure 6-5. On-Resistance vs Temperature

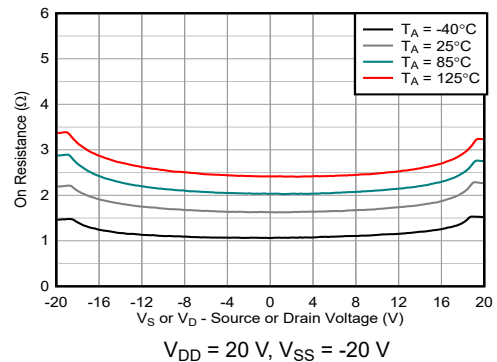

Figure 6-6. On-Resistance vs Temperature

6.6 Typical Characteristics (continued)

at $T_A = 25^\circ\text{C}$ (unless otherwise noted)

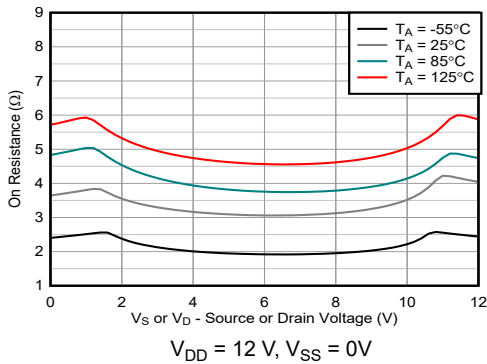

Figure 6-7. On-Resistance vs Temperature

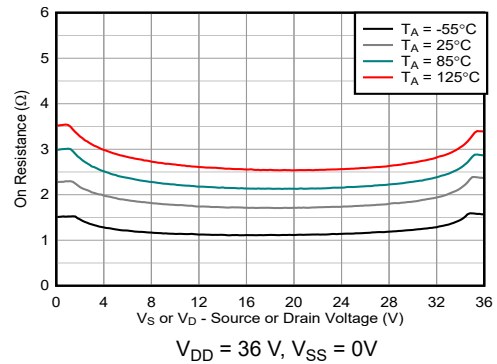

Figure 6-8. On-Resistance vs Temperature

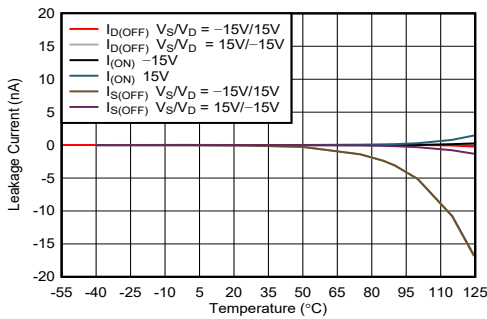

Figure 6-9. Leakage Current vs Temperature

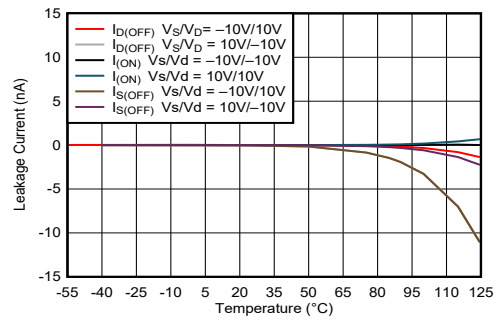

Figure 6-10. Leakage Current vs Temperature

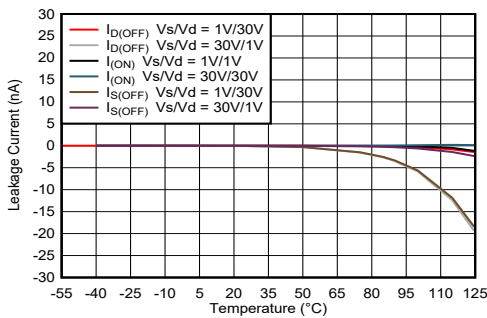

Figure 6-11. Leakage Current vs Temperature

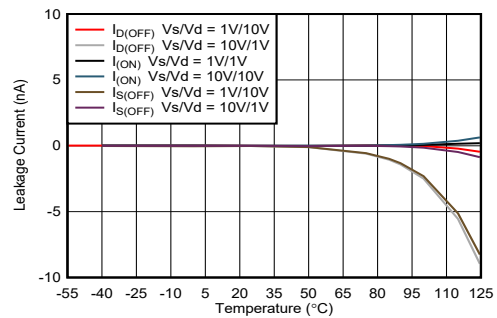

Figure 6-12. Leakage Current vs Temperature

6.6 Typical Characteristics (continued)

at $T_A = 25^\circ\text{C}$ (unless otherwise noted)

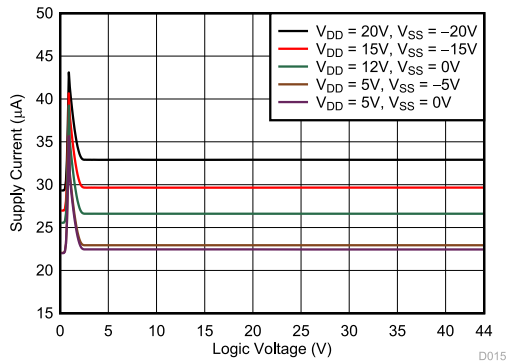

Figure 6-13. Supply Current vs. Logic Voltage

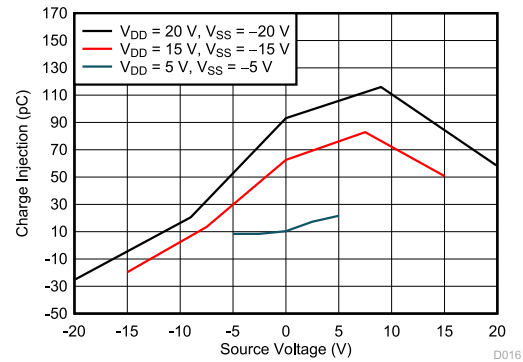

Figure 6-14. Charge Injection vs. Source Voltage – Dual Supply

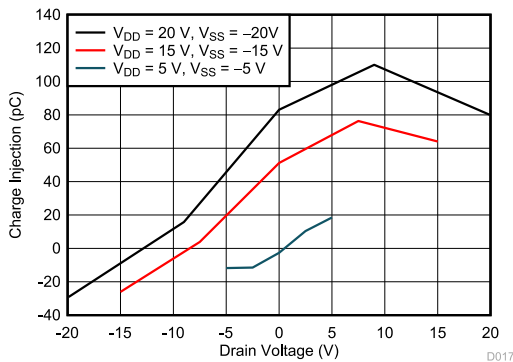

Figure 6-15. Charge Injection vs. Drain Voltage – Dual Supply

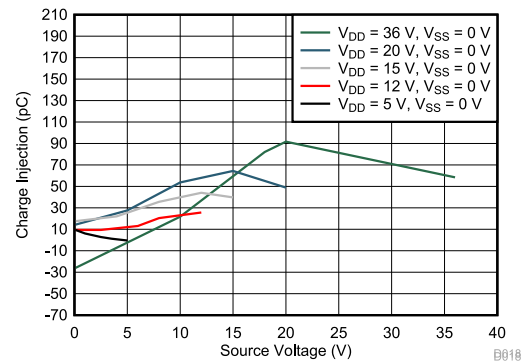

Figure 6-16. Charge Injection vs. Source Voltage – Single Supply

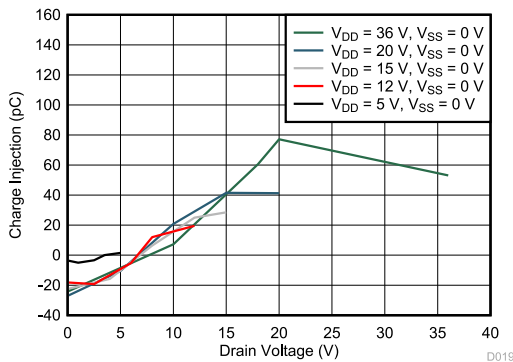

Figure 6-17. Charge Injection vs. Drain Voltage – Single Supply

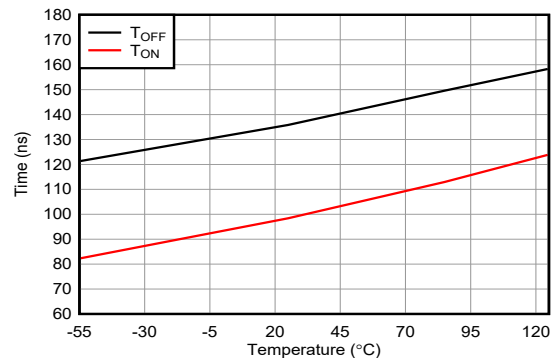

Figure 6-18. T_{ON} and T_{OFF} vs. Temperature

6.6 Typical Characteristics (continued)

at $T_A = 25^\circ\text{C}$ (unless otherwise noted)

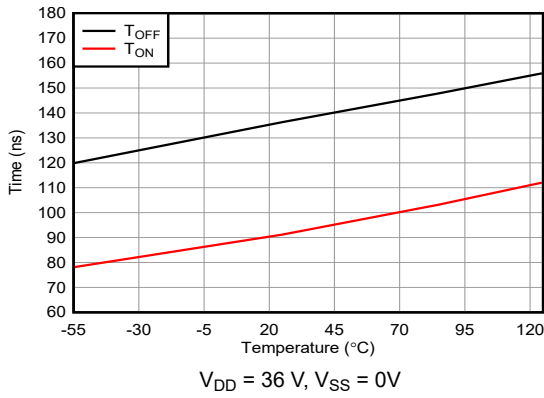

Figure 6-19. T_{ON} and T_{OFF} vs. Temperature

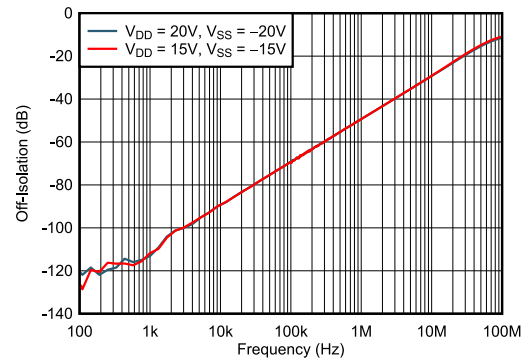

Figure 6-20. Off-Isolation vs Frequency

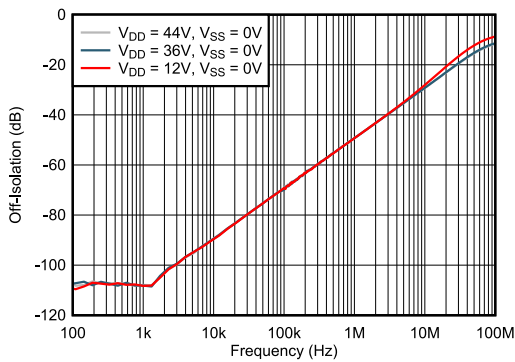

Figure 6-21. Off-Isolation vs Frequency

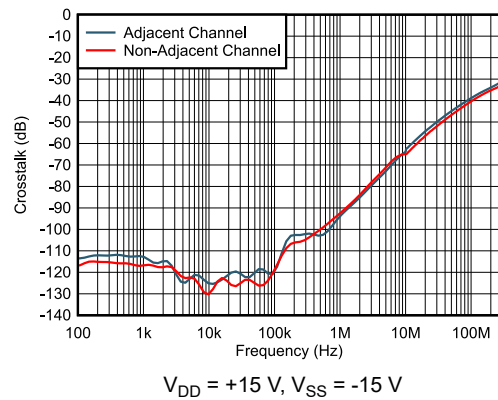

Figure 6-22. Crosstalk vs Frequency

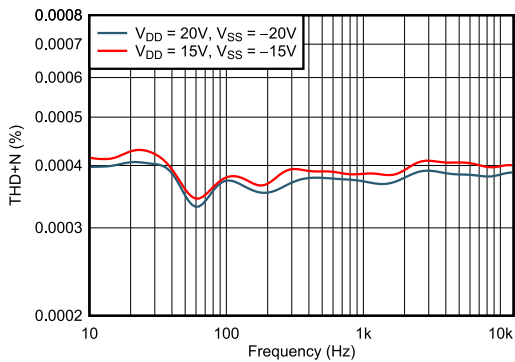

Figure 6-23. THD+N vs. Frequency (Dual Supplies)

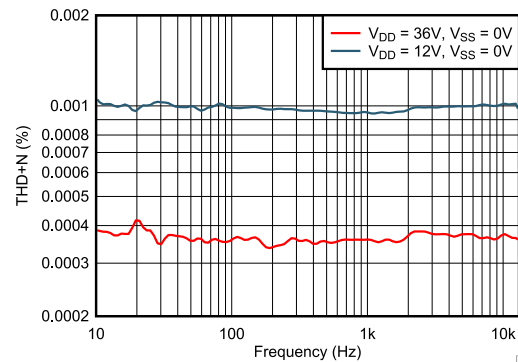

Figure 6-24. THD+N vs. Frequency (Single Supplies)

D029

6.6 Typical Characteristics (continued)

at $T_A = 25^\circ\text{C}$ (unless otherwise noted)

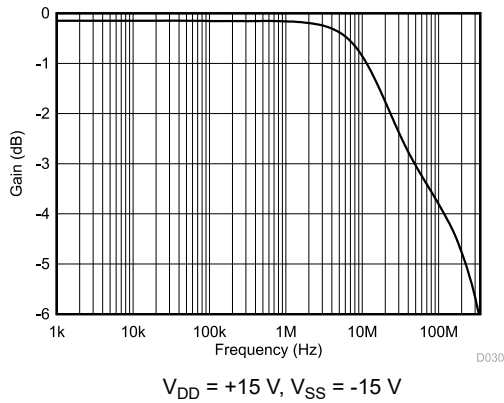

Figure 6-25. On Response vs Frequency

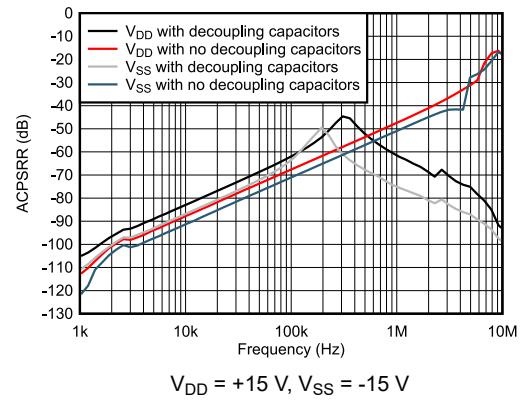

Figure 6-26. ACPSRR vs. Frequency

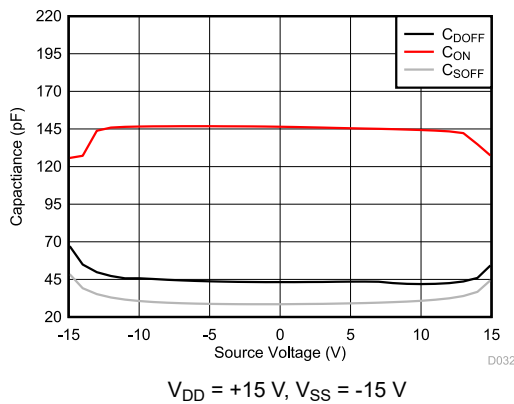

Figure 6-27. Capacitance vs. Source Voltage or Drain Voltage

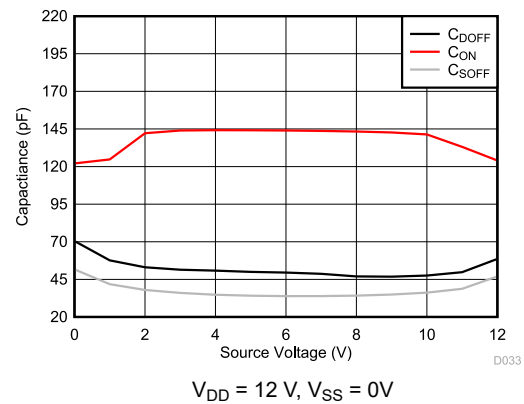

Figure 6-28. Capacitance vs. Source Voltage or Drain Voltage

7 Parameter Measurement Information

7.1 On-Resistance

The on-resistance of a device is the ohmic resistance between the source (Sx) and drain (Dx) pins of the device. The on-resistance varies with input voltage and supply voltage. The symbol R_{ON} is used to denote on-resistance. Figure 7-1 shows the measurement setup used to measure R_{ON} . Voltage (V) and current (I_{SD}) are measured using this setup, and R_{ON} is computed with $R_{ON} = V / I_{SD}$:

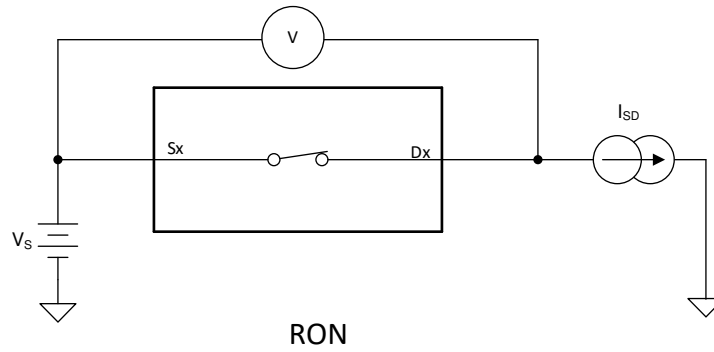

Figure 7-1. On-Resistance Measurement Setup

7.2 Off-Leakage Current

There are two types of leakage currents associated with a switch during the off state:

1. Source off-leakage current.
2. Drain off-leakage current.

Source leakage current is defined as the leakage current flowing into or out of the source pin when the switch is off. This current is denoted by the symbol $I_{S(OFF)}$.

Drain leakage current is defined as the leakage current flowing into or out of the drain pin when the switch is off. This current is denoted by the symbol $I_{D(OFF)}$.

Figure 7-2 shows the setup used to measure both off-leakage currents.

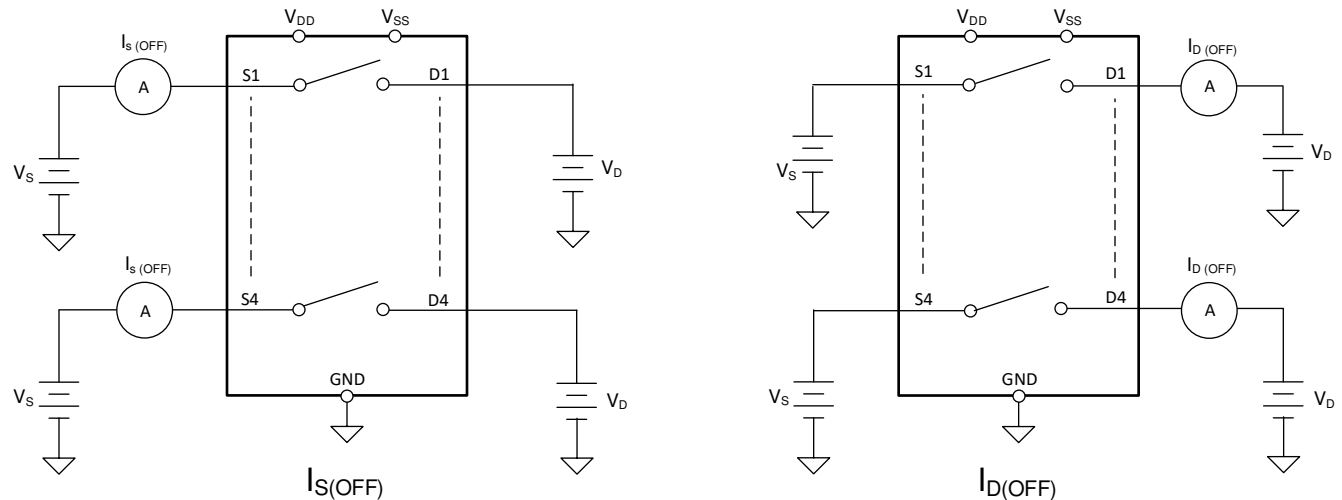

Figure 7-2. Off-Leakage Measurement Setup

7.3 On-Leakage Current

Source on-leakage current is defined as the leakage current flowing into or out of the source pin when the switch is on. This current is denoted by the symbol $I_{S(ON)}$.

Drain on-leakage current is defined as the leakage current flowing into or out of the drain pin when the switch is on. This current is denoted by the symbol $I_{D(ON)}$.

Either the source pin or drain pin is left floating during the measurement. Figure 7-3 shows the circuit used for measuring the on-leakage current, denoted by $I_{S(ON)}$ or $I_{D(ON)}$.

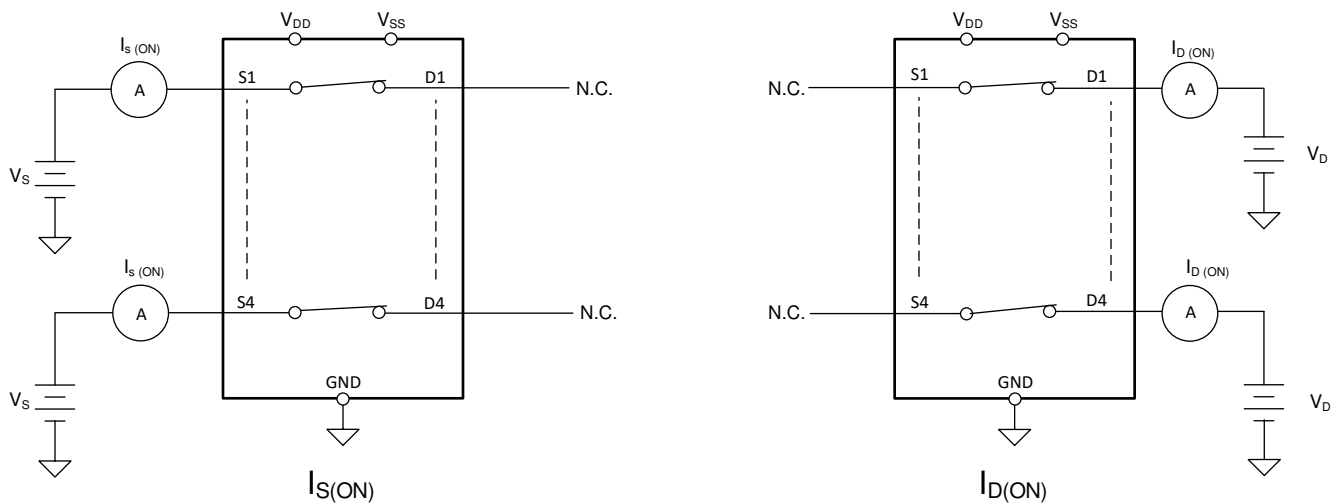

Figure 7-3. On-Leakage Measurement Setup

7.4 t_{ON} and t_{OFF} Time

Turn-on time is defined as the time taken by the output of the device to rise to 90% after the enable has risen past the logic threshold. The 90% measurement is utilized to provide the timing of the device. System level timing can then account for the time constant added from the load resistance and load capacitance. Figure 7-4 shows the setup used to measure turn-on time, denoted by the symbol t_{ON} .

Turn-off time is defined as the time taken by the output of the device to fall to 10% after the enable has fallen past the logic threshold. The 10% measurement is utilized to provide the timing of the device. System level timing can then account for the time constant added from the load resistance and load capacitance. Figure 7-4 shows the setup used to measure turn-off time, denoted by the symbol t_{OFF} .

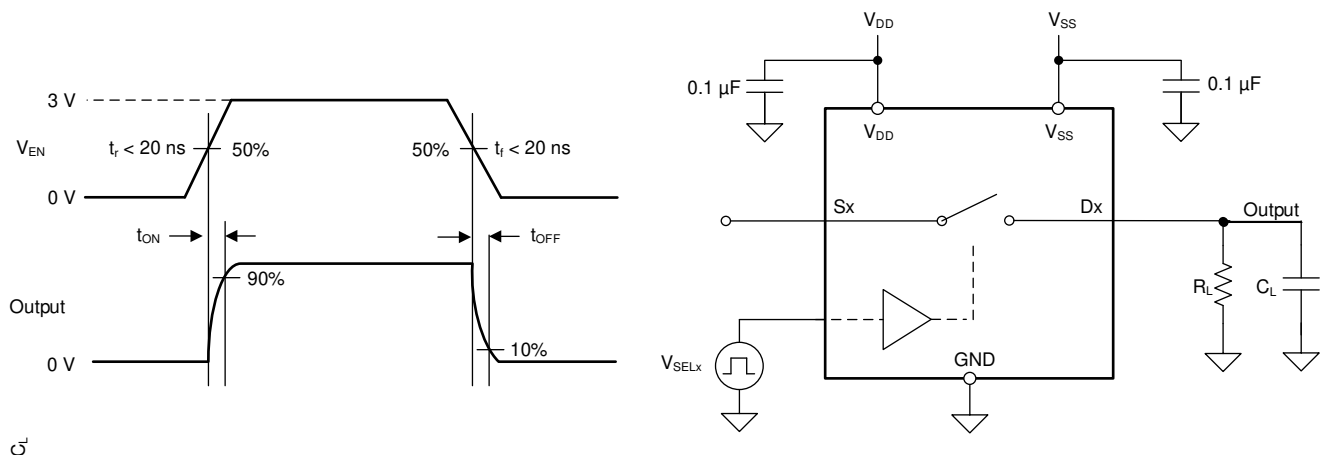

Figure 7-4. Turn-On and Turn-Off Time Measurement Setup

7.5 $t_{ON(VDD)}$ Time

The $t_{ON(VDD)}$ time is defined as the time taken by the output of the device to rise to 90% after the supply has risen past the supply threshold. The 90% measurement is used to provide the timing of the device turning on in the system. Figure 7-5 shows the setup used to measure turn on time, denoted by the symbol $t_{ON(VDD)}$.

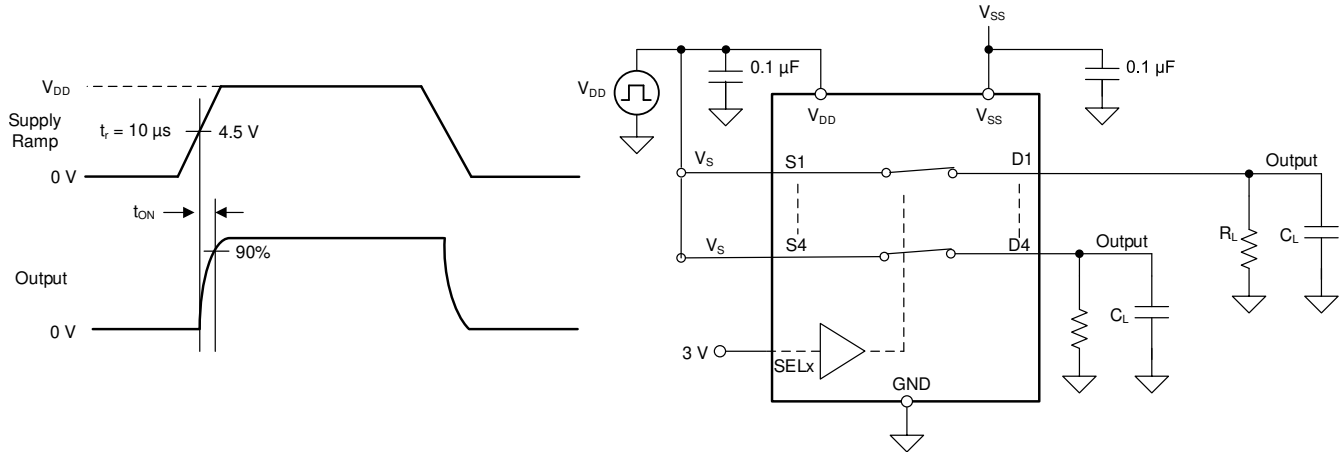

Figure 7-5. $t_{ON(VDD)}$ Time Measurement Setup

7.6 Propagation Delay

Propagation delay is defined as the time taken by the output of the device to rise or fall 50% after the input signal has risen or fallen past the 50% threshold. Figure 7-6 shows the setup used to measure propagation delay, denoted by the symbol t_{PD} .

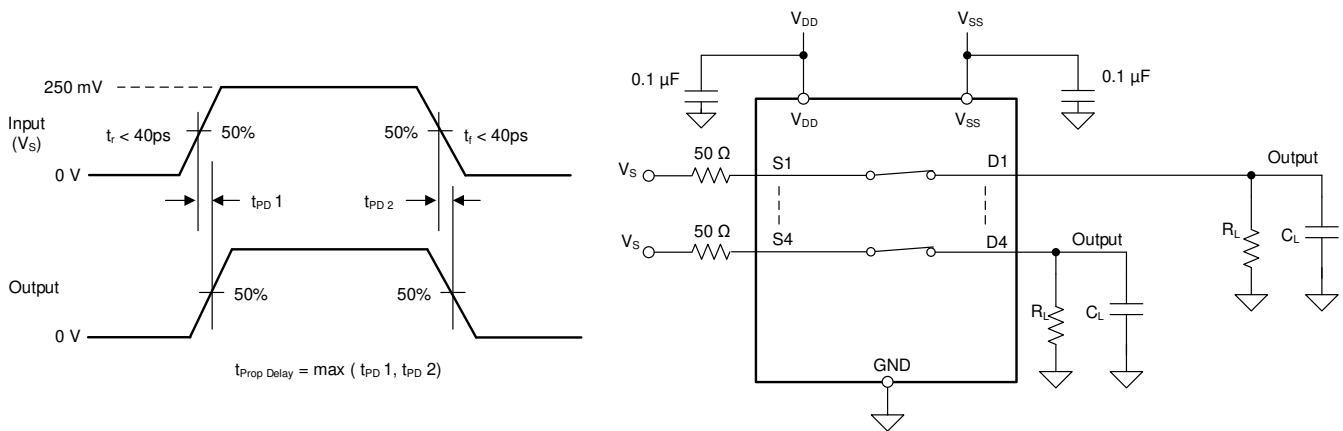

Figure 7-6. Propagation Delay Measurement Setup

7.7 Charge Injection

The TMUX7212M devices have a transmission-gate topology. Any mismatch in capacitance between the NMOS and PMOS transistors results in a charge injected into the drain or source during the falling or rising edge of the gate signal. The amount of charge injected into the source or drain of the device is known as charge injection, and is denoted by the symbol Q_C . Figure 7-7 shows the setup used to measure charge injection from source (Sx) to drain (Dx).

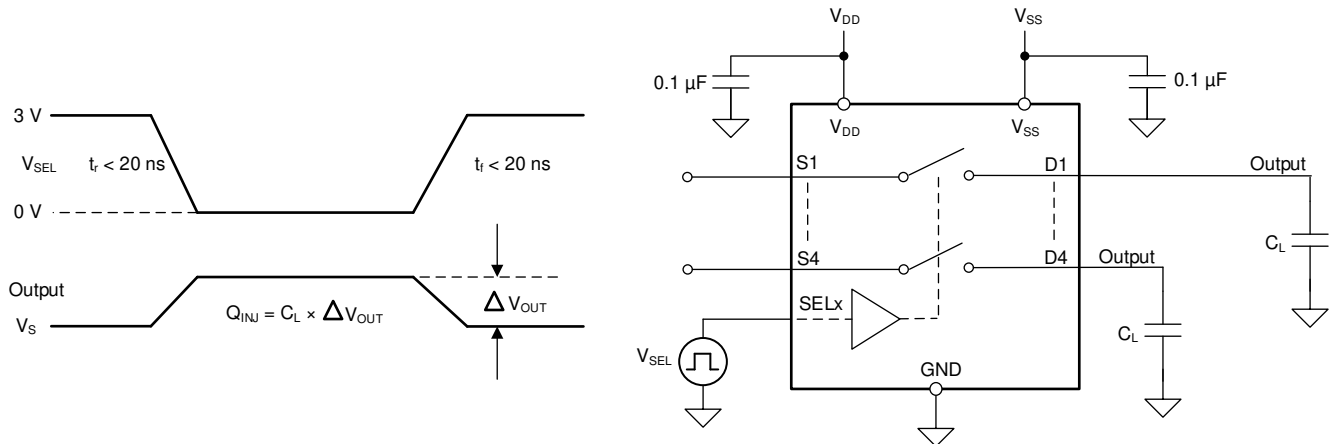

Figure 7-7. Charge-Injection Measurement Setup

7.8 Off Isolation

Off isolation is defined as the ratio of the signal at the drain pin (Dx) of the device when a signal is applied to the source pin (Sx) of an off-channel. The characteristic impedance, Z_0 , for the measurement is 50 Ω. Figure 7-8 shows the setup used to measure off isolation. Use off isolation equation to compute off isolation.

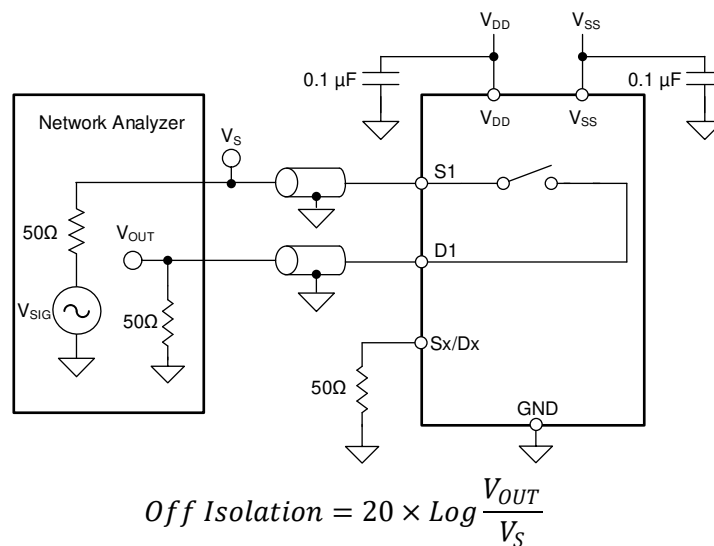

Figure 7-8. Off Isolation Measurement Setup

7.9 Channel-to-Channel Crosstalk

Crosstalk is defined as the ratio of the signal at the drain pin (Dx) of a different channel, when a signal is applied at the source pin (Sx) of an on-channel. The characteristic impedance, Z_0 , for the measurement is 50 Ω . Figure 7-9 shows the setup used to measure, and the equation used to compute crosstalk.

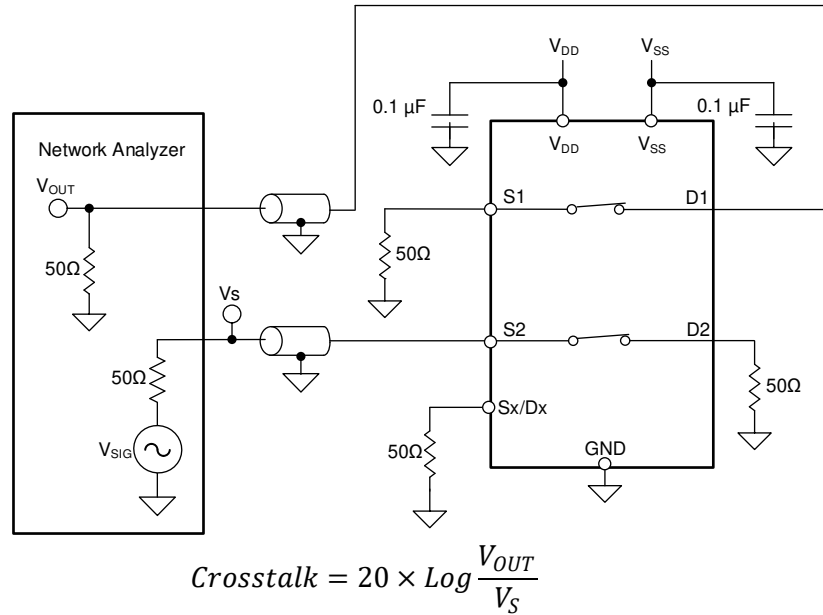

Figure 7-9. Channel-to-Channel Crosstalk Measurement Setup

7.10 Bandwidth

Bandwidth is defined as the range of frequencies that are attenuated by less than 3 dB when the input is applied to the source pin (Sx) of an on-channel, and the output is measured at the drain pin (Dx) of the device. The characteristic impedance, Z_0 , for the measurement is 50 Ω . Figure 7-10 shows the setup used to measure bandwidth.

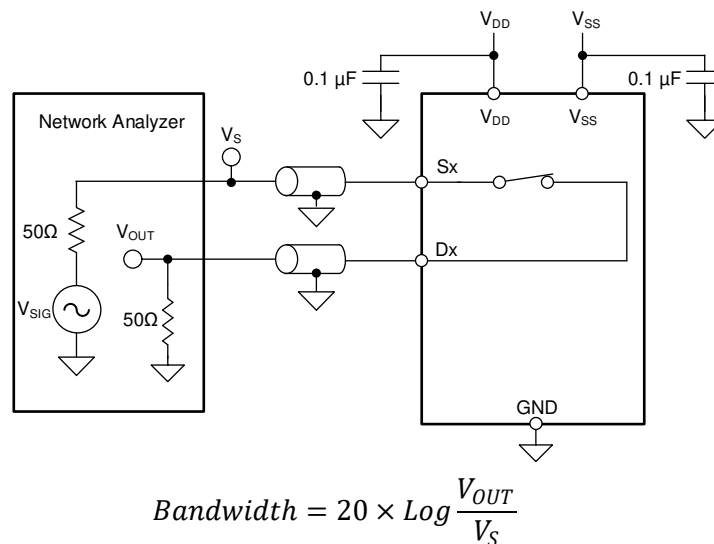

Figure 7-10. Bandwidth Measurement Setup

7.11 THD + Noise

The total harmonic distortion (THD) of a signal is a measurement of the harmonic distortion, and is defined as the ratio of the sum of the powers of all harmonic components to the power of the fundamental frequency at the mux output. The on-resistance of the device varies with the amplitude of the input signal and results in distortion when the drain pin is connected to a low-impedance load. Total harmonic distortion plus noise is denoted as THD + N.

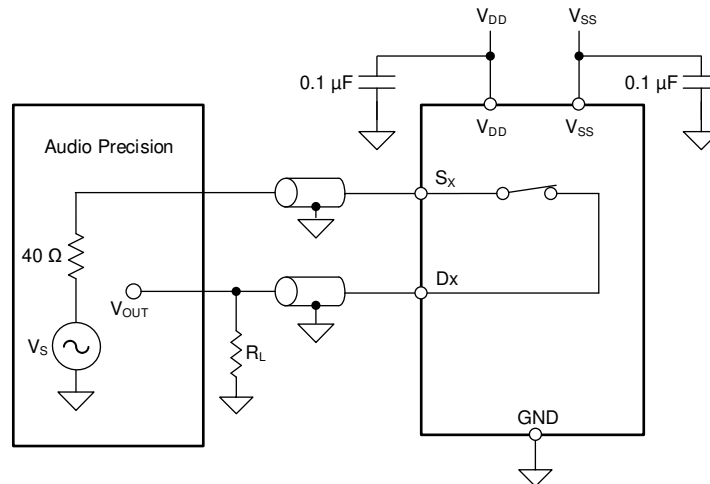

Figure 7-11. THD + N Measurement Setup

7.12 Power Supply Rejection Ratio (PSRR)

PSRR measures the ability of a device to prevent noise and spurious signals that appear on the supply voltage pin from coupling to the output of the switch. The DC voltage on the device supply is modulated by a sine wave of 100 mV_{PP}. The ratio of the amplitude of signal on the output to the amplitude of the modulated signal is the AC PSRR.

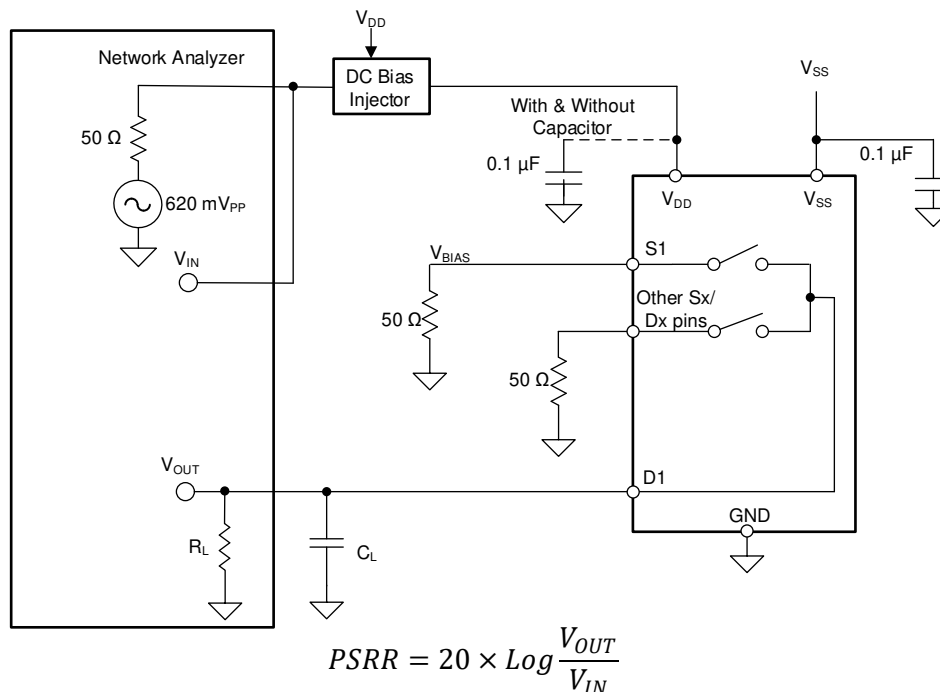

Figure 7-12. AC PSRR Measurement Setup

8 Detailed Description

8.1 Overview

The TMUX7212M is a 1:1 (SPST), 4-channel switch. The device has four independently selectable single-pole, single-throw switches that are turned-on or turned-off based on the state of the corresponding select pin.

8.2 Functional Block Diagram

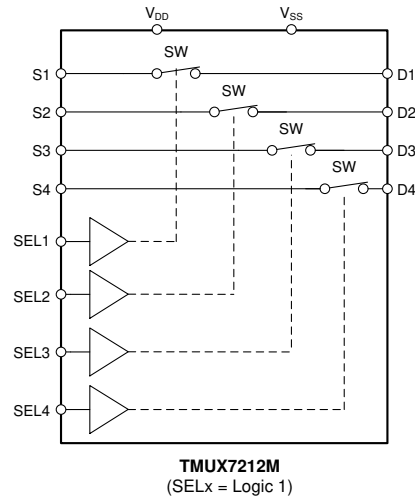

8.3 Feature Description

8.3.1 Bidirectional Operation

The TMUX7212M conducts equally well from source (Sx) to drain (Dx) or from drain (Dx) to source (Sx). Each channel has similar characteristics in both directions and supports both analog and digital signals.

8.3.2 Rail-to-Rail Operation

The valid signal path input and output voltage for TMUX7212M ranges from V_{SS} to V_{DD} .

8.3.3 1.8V Logic Compatible Inputs

The TMUX7212M device has 1.8V logic compatible control for all logic control inputs. 1.8V logic level inputs allows the TMUX7212M to interface with processors that have lower logic I/O rails and eliminates the need for an external translator, which saves both space and bill of material cost. For more information on 1.8V logic implementations refer to [Simplifying Design with 1.8V logic Muxes and Switches](#).

8.3.4 Integrated Pull-Down Resistor on Logic Pins

The TMUX7212M has internal weak pull-down resistors to GND to ensure the logic pins are not left floating. The value of this pull-down resistor is approximately $4M\Omega$, but is clamped to about $1\ \mu A$ at higher voltages. This feature integrates up to four external components and reduces system size and cost.

8.3.5 Fail-Safe Logic

The TMUX7212M supports Fail-Safe Logic on the control input pins (SEL1, SEL2, SEL3, and SEL4) allowing for operation up to 44 V, regardless of the state of the supply pin. This feature allows voltages on the control pins to be applied before the supply pin, protecting the device from potential damage. Fail-Safe Logic minimizes system complexity by removing the need for power supply sequencing on the logic control pins. For example, the Fail-Safe Logic feature allows the select pins of the TMUX7212M to be ramped to 44 V while V_{DD} and $V_{SS} = 0V$. The logic control inputs are protected against positive faults of up to 44 V in powered-off condition, but do not offer protection against negative overvoltage conditions.

8.3.6 Latch-Up Immune

Latch-up is a condition where a low impedance path is created between a supply pin and ground. This condition is caused by a trigger (current injection or overvoltage), but once activated, the low impedance path remains even after the trigger is no longer present. This low impedance path may cause system upset or catastrophic damage due to excessive current levels. The latch-up condition typically requires a power cycle to eliminate the low impedance path.

The TMUX7212M family of devices are constructed on silicon on insulator (SOI) based process where an oxide layer is added between the PMOS and NMOS transistor of each CMOS switch to prevent parasitic structures from forming. The oxide layer is also known as an insulating trench and prevents triggering of latch up events due to overvoltage or current injections. The latch-up immunity feature allows the TMUX7212M family of switches and multiplexers to be used in harsh environments. For more information on latch-up immunity refer to [Using Latch Up Immune Multiplexers to Help Improve System Reliability](#).

8.3.7 Ultra-Low Charge Injection

Figure 8-1 shows how the TMUX7212M devices have a transmission gate topology. Any mismatch in the stray capacitance associated with the NMOS and PMOS causes an output level change whenever the switch is opened or closed.

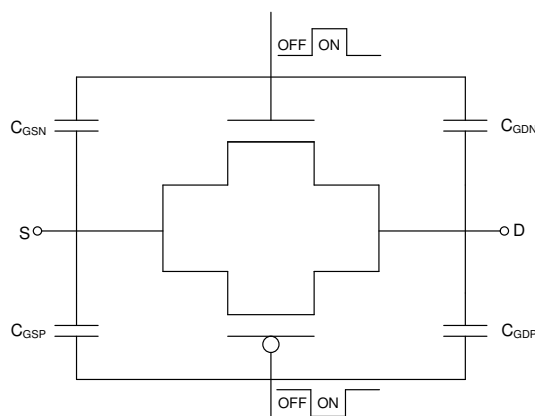

Figure 8-1. Transmission Gate Topology

The TMUX7212M contains specialized architecture to reduce charge injection on the Drain (Dx). To further reduce charge injection in a sensitive application, a compensation capacitor (C_p) can be added on the Source (Sx). This will ensure that excess charge from the switch transition will be pushed into the compensation capacitor on the Source (Sx) instead of the Drain (Dx). As a general rule, C_p should be 20x larger than the equivalent load capacitance on the Drain (Dx). Figure 8-2 shows charge injection variation with different compensation capacitors on the Source side. This plot was captured on the TMUX7219M as part of the TMUX72xx family with a 100 pF load capacitance.

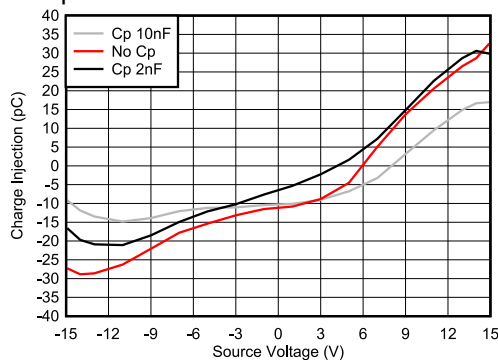

Figure 8-2. Charge Injection Compensation

8.4 Device Functional Modes

The TMUX7212M device has four independently selectable single-pole, single-throw switches that are turned-on or turned-off based on the state of the corresponding select pin. The control pins can be as high as 44 V.

The TMUX7212M devices can operate without any external components except for the supply decoupling capacitors. The SELx pins have internal pull-down resistors of 4MΩ. If unused, then the SELx pin must be tied to GND for the device to not consume additional current as highlighted in [Implications of Slow or Floating CMOS Inputs](#). Unused signal path inputs (Sx or Dx) should be connected to GND.

8.5 Truth Tables

[Table 8-1](#) shows the truth tables for the TMUX7212M.

Table 8-1. TMUX7212M Truth Table

SEL x ⁽¹⁾	CHANNEL x
0	Channel x OFF
1	Channel x ON

(1) x denotes 1, 2, 3, or 4 for the corresponding channel.

9 Application and Implementation

Note

Information in the following applications sections is not part of the TI component specification, and TI does not warrant its accuracy or completeness. TI's customers are responsible for determining suitability of components for their purposes, as well as validating and testing their design implementation to confirm system functionality.

9.1 Application Information

The TMUX7212M is part of the precision switches and multiplexers family of devices. These devices operate with dual supplies ($\pm 4.5\text{V}$ to $\pm 22\text{V}$), a single supply (4.5V to 44 V), or asymmetric supplies (such as $V_{DD} = 12\text{V}$, $V_{SS} = -30\text{V}$), and offer true rail-to-rail input and output. The TMUX7212M offers low R_{ON} , low on and off leakage currents and ultra-low charge injection performance. These features makes the TMUX7212M a family of precision, robust, high-performance analog multiplexer for high-voltage, automotive applications.

9.2 Typical Application – Switched Gain Amplifier

Switches and multiplexers are commonly used in the feedback path of amplifier circuits to provide configurable gain control. By using various resistor values on each switch path the TMUX7212M allows the system to have multiple gain settings. An external resistor, or utilizing 1 channel always being closed, ensures the amplifier is not operating in an open loop configuration. The leakage current, On-Resistance, and charge injection performance of the TMUX7212M are key specifications to evaluate when selecting a device for gain control.

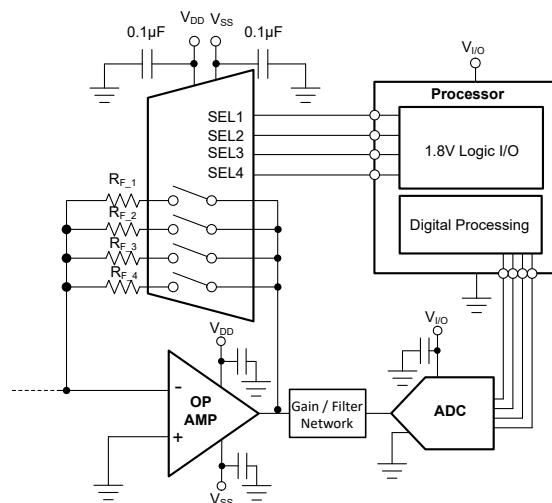

Figure 9-1. Switching Gain Settings

9.3 Design Requirements

For this design example, use the parameters listed in [Table 9-1](#).

Table 9-1. Design Parameters

PARAMETERS	VALUES
Supply (V_{DD})	15 V
Supply (V_{SS})	- 15 V
Input / Output signal range	-15 V to 15 V (Rail-to-Rail)
Control logic thresholds	1.8V compatible

9.4 Detailed Design Procedure

The TMUX7212M device can be operated without any external components except for the supply decoupling capacitors. All inputs signals passing through the switch must fall within the recommended operating conditions of the TMUX7212M including signal range and continuous current. For this design example, with a supply of +15 V and -15V, the signals can range from +15 V to -15V when the device is powered. The maximum continuous current can be 220mA.

The application shown in [Switching Gain Settings](#) demonstrates how to use the TMUX7212M to control the feedback gain of a precision op-amp. This feedback design can very sensitive to induced voltage and current offsets. The TMUX7212M has a typical On-leakage current of 100 pA which would lead to an accuracy well within 1% of a full scale 1 μ A signal, thus minimizing errors from current offsets. The low On-Resistance of the TMUX7212M leads to a low error in the feedback resistance and resulting gain. This additionally minimizes any voltage offsets.

9.5 Power Supply Recommendations

The TMUX7212M device operates across a wide supply range of ± 4.5 V to ± 22 V (4.5V to 44 V in single-supply mode). The device also perform well with asymmetrical supplies such as $V_{DD} = 12$ V and $V_{SS} = -5$ V.

Power-supply bypassing improves noise margin and prevents switching noise propagation from the supply rails to other components. Good power-supply decoupling is important to achieve optimum performance. For improved supply noise immunity, use a supply decoupling capacitor ranging from 0.1 μ F to 10 μ F at both the V_{DD} and V_{SS} pins to ground. Place the bypass capacitors as close to the power supply pins of the device as possible using low-impedance connections. TI recommends using multi-layer ceramic chip capacitors (MLCCs) that offer low equivalent series resistance (ESR) and inductance (ESL) characteristics for power-supply decoupling purposes. For very sensitive systems, or for systems in harsh noise environments, avoiding the use of vias for connecting the capacitors to the device pins may offer superior noise immunity. The use of multiple vias in parallel lowers the overall inductance and is beneficial for connections to ground and power planes. Always ensure the ground (GND) connection is established before supplies are ramped.

9.6 Layout

9.6.1 Layout Guidelines

When a PCB trace turns a corner at a 90° angle, a reflection can occur. A reflection occurs primarily because of the change of width of the trace. At the apex of the turn, the trace width increases to 1.414 times the width. This increase upsets the transmission-line characteristics, especially the distributed capacitance and self-inductance of the trace which results in the reflection. Not all PCB traces can be straight and therefore some traces must turn corners. [Figure 9-2](#) shows progressively better techniques of rounding corners. Only the last example (BEST) maintains constant trace width and minimizes reflections.

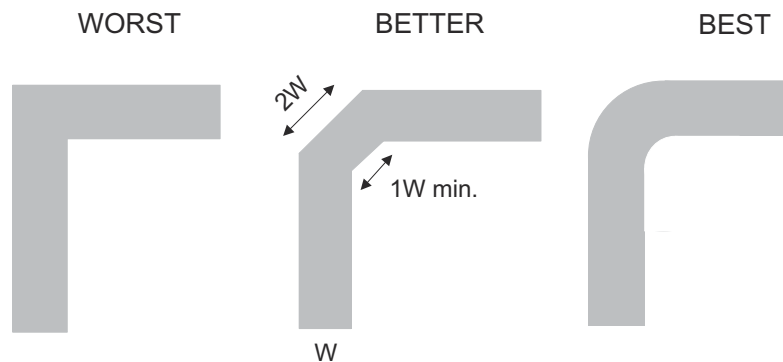

Figure 9-2. Trace Example

Route high-speed signals using a minimum of vias and corners which reduces signal reflections and impedance changes. When a via must be used, increase the clearance size around it to minimize its capacitance. Each via introduces discontinuities in the signal's transmission line and increases the chance of picking up interference from the other layers of the board. Be careful when designing test points, through-hole pins are not recommended at high frequencies.

Some key considerations are:

- For reliable operation, connect a decoupling capacitor ranging from 0.1µF to 10µF between VDD/VSS and GND. We recommend a 0.1µF and 1µF capacitor, placing the lowest value capacitor as close to the pin as possible. Make sure that the capacitor voltage rating is sufficient for the supply voltage.
- Keep the input lines as short as possible.
- Use a solid ground plane to help reduce electromagnetic interference (EMI) noise pickup.
- Do not run sensitive analog traces in parallel with digital traces. Avoid crossing digital and analog traces if possible, and only make perpendicular crossings when necessary.
- Using multiple vias in parallel will lower the overall inductance and is beneficial for connection to ground planes.

9.6.2 Layout Example

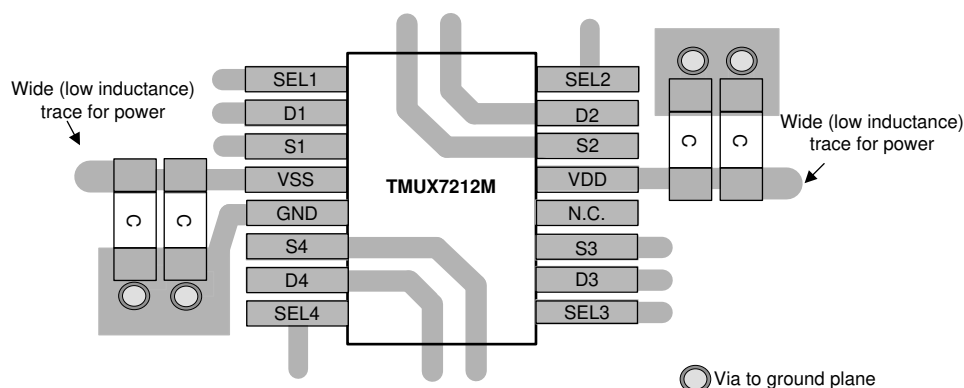

Figure 9-3. TMUX7212M Layout Example

10 Device and Documentation Support

10.1 Documentation Support

10.1.1 Related Documentation

- Texas Instruments, [Using Latch Up Immune Multiplexers to Help Improve System Reliability](#) application note
- Texas Instruments, [Improve Stability Issues with Low CON Multiplexers](#) application brief
- Texas Instruments, [Improving Signal Measurement Accuracy in Automated Test Equipment](#) application brief
- Texas Instruments, [Sample & Hold Glitch Reduction for Precision Outputs Reference Design](#) reference guide
- Texas Instruments, [Simplifying Design with 1.8V logic Muxes and Switches](#) application brief
- Texas Instruments, [System-Level Protection for High-Voltage Analog Multiplexers](#) application note
- Texas Instruments, [True Differential, 4 x 2 MUX, Analog Front End, Simultaneous-Sampling ADC Circuit](#) application note
- Texas Instruments, [Quad Flatpack No-Lead Logic Packages](#) application note

10.2 Receiving Notification of Documentation Updates

To receive notification of documentation updates, navigate to the device product folder on [ti.com](#). Click on *Notifications* to register and receive a weekly digest of any product information that has changed. For change details, review the revision history included in any revised document.

10.3 Support Resources

[TI E2E™ support forums](#) are an engineer's go-to source for fast, verified answers and design help — straight from the experts. Search existing answers or ask your own question to get the quick design help you need.

Linked content is provided "AS IS" by the respective contributors. They do not constitute TI specifications and do not necessarily reflect TI's views; see TI's [Terms of Use](#).

10.4 Trademarks

TI E2E™ is a trademark of Texas Instruments.
All trademarks are the property of their respective owners.

10.5 Electrostatic Discharge Caution



This integrated circuit can be damaged by ESD. Texas Instruments recommends that all integrated circuits be handled with appropriate precautions. Failure to observe proper handling and installation procedures can cause damage.

ESD damage can range from subtle performance degradation to complete device failure. Precision integrated circuits may be more susceptible to damage because very small parametric changes could cause the device not to meet its published specifications.

10.6 Glossary

[TI Glossary](#) This glossary lists and explains terms, acronyms, and definitions.

11 Revision History

DATE	REVISION	NOTES
January 2024	*	Initial Release

12 Mechanical, Packaging, and Orderable Information

The following pages include mechanical, packaging, and orderable information. This information is the most current data available for the designated devices. This data is subject to change without notice and revision of this document. For browser-based versions of this data sheet, refer to the left-hand navigation.

PACKAGING INFORMATION

Orderable Device	Status (1)	Package Type	Package Drawing	Pins	Package Qty	Eco Plan (2)	Lead finish/ Ball material (6)	MSL Peak Temp (3)	Op Temp (°C)	Device Marking (4/5)	Samples
TMUX7212MPWR	ACTIVE	TSSOP	PW	16	2500	RoHS & Green	NIPDAU	Level-1-260C-UNLIM	-55 to 125	X212	Samples

(1) The marketing status values are defined as follows:

ACTIVE: Product device recommended for new designs.

LIFEBUY: TI has announced that the device will be discontinued, and a lifetime-buy period is in effect.

NRND: Not recommended for new designs. Device is in production to support existing customers, but TI does not recommend using this part in a new design.

PREVIEW: Device has been announced but is not in production. Samples may or may not be available.

OBSOLETE: TI has discontinued the production of the device.

(2) **RoHS:** TI defines "RoHS" to mean semiconductor products that are compliant with the current EU RoHS requirements for all 10 RoHS substances, including the requirement that RoHS substance do not exceed 0.1% by weight in homogeneous materials. Where designed to be soldered at high temperatures, "RoHS" products are suitable for use in specified lead-free processes. TI may reference these types of products as "Pb-Free".

RoHS Exempt: TI defines "RoHS Exempt" to mean products that contain lead but are compliant with EU RoHS pursuant to a specific EU RoHS exemption.

Green: TI defines "Green" to mean the content of Chlorine (Cl) and Bromine (Br) based flame retardants meet JS709B low halogen requirements of <=1000ppm threshold. Antimony trioxide based flame retardants must also meet the <=1000ppm threshold requirement.

(3) MSL, Peak Temp. - The Moisture Sensitivity Level rating according to the JEDEC industry standard classifications, and peak solder temperature.

(4) There may be additional marking, which relates to the logo, the lot trace code information, or the environmental category on the device.

(5) Multiple Device Markings will be inside parentheses. Only one Device Marking contained in parentheses and separated by a "~" will appear on a device. If a line is indented then it is a continuation of the previous line and the two combined represent the entire Device Marking for that device.

(6) Lead finish/Ball material - Orderable Devices may have multiple material finish options. Finish options are separated by a vertical ruled line. Lead finish/Ball material values may wrap to two lines if the finish value exceeds the maximum column width.

Important Information and Disclaimer: The information provided on this page represents TI's knowledge and belief as of the date that it is provided. TI bases its knowledge and belief on information provided by third parties, and makes no representation or warranty as to the accuracy of such information. Efforts are underway to better integrate information from third parties. TI has taken and continues to take reasonable steps to provide representative and accurate information but may not have conducted destructive testing or chemical analysis on incoming materials and chemicals. TI and TI suppliers consider certain information to be proprietary, and thus CAS numbers and other limited information may not be available for release.

In no event shall TI's liability arising out of such information exceed the total purchase price of the TI part(s) at issue in this document sold by TI to Customer on an annual basis.

IMPORTANT NOTICE AND DISCLAIMER

TI PROVIDES TECHNICAL AND RELIABILITY DATA (INCLUDING DATA SHEETS), DESIGN RESOURCES (INCLUDING REFERENCE DESIGNS), APPLICATION OR OTHER DESIGN ADVICE, WEB TOOLS, SAFETY INFORMATION, AND OTHER RESOURCES "AS IS" AND WITH ALL FAULTS, AND DISCLAIMS ALL WARRANTIES, EXPRESS AND IMPLIED, INCLUDING WITHOUT LIMITATION ANY IMPLIED WARRANTIES OF MERCHANTABILITY, FITNESS FOR A PARTICULAR PURPOSE OR NON-INFRINGEMENT OF THIRD PARTY INTELLECTUAL PROPERTY RIGHTS.

These resources are intended for skilled developers designing with TI products. You are solely responsible for (1) selecting the appropriate TI products for your application, (2) designing, validating and testing your application, and (3) ensuring your application meets applicable standards, and any other safety, security, regulatory or other requirements.

These resources are subject to change without notice. TI grants you permission to use these resources only for development of an application that uses the TI products described in the resource. Other reproduction and display of these resources is prohibited. No license is granted to any other TI intellectual property right or to any third party intellectual property right. TI disclaims responsibility for, and you will fully indemnify TI and its representatives against, any claims, damages, costs, losses, and liabilities arising out of your use of these resources.

TI's products are provided subject to [TI's Terms of Sale](#) or other applicable terms available either on [ti.com](https://www.ti.com) or provided in conjunction with such TI products. TI's provision of these resources does not expand or otherwise alter TI's applicable warranties or warranty disclaimers for TI products.

TI objects to and rejects any additional or different terms you may have proposed.

Mailing Address: Texas Instruments, Post Office Box 655303, Dallas, Texas 75265
Copyright © 2024, Texas Instruments Incorporated