

SN54SLC8T245-SEP 8-Bit Dual-Supply Bus Transceiver With Configurable Voltage Translation and Tri-State Outputs

1 Features

- VID V62/22604
- Radiation tolerant:
 - Single event latch-up (SEL) immune up to 43 MeV-cm² /mg at 125°C
 - Total ionizing dose (TID) Radiation Lot Acceptance Testing (RLAT) for every wafer lot up to 20 krad(Si)
- Qualified, fully configurable dual-rail design allows each port to operate with a power supply range from 0.65 V to 3.6 V
- Operating temperature from –55°C to +125°C
- Multiple direction-control pins allows simultaneous up and down translation
- Up to 380 Mbps support when translating from 1.8 V to 3.3 V
- V_{CC} isolation feature that effectively isolates both buses in a power-down scenario
- Partial power-down mode to limit backflow current in a power-down scenario
- Latch-up performance exceeds 100 mA per JESD 78, class II
- ESD protection exceeds JESD 22
 - 8000-V human-body model
 - 1000-V charged-device model

2 Applications

- [Supports low earth orbit \(LEO\) space applications](#)
- [Space radar and communications](#)
- [Space satellite payloads](#)

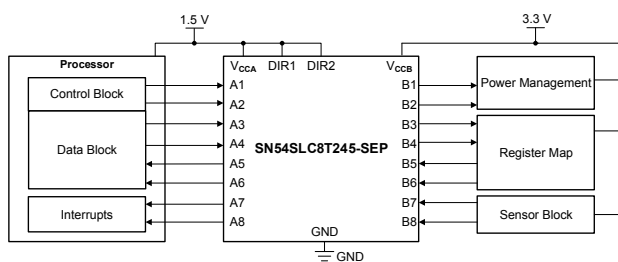

Typical Application Schematic

3 Description

The SN54SLC8T245-SEP device is an 8-bit non-inverting bus transceiver that resolves voltage level mismatch between devices operating at the latest voltage nodes (0.7 V, 0.8 V, and 0.9 V) and devices operating at industry standard voltage nodes (1.8 V, 2.5 V, and 3.3 V).

The device operates by using two independent power-supply rails (V_{CCA} and V_{CCB}) that operate as low as 0.65 V. Data pins A1 through A8 are designed to track V_{CCA}, which accepts any supply voltage from 0.65 V to 3.6 V. Data pins B1 through B8 are designed to track V_{CCB}, which accepts any supply voltage from 0.65 V to 3.6 V.

The SN54SLC8T245-SEP device is designed for asynchronous communication between data buses. The device transmits data from the A bus to the B bus or from the B bus to the A bus, depending on the logic level of the direction-control inputs (DIR1 and DIR2). The output-enable (\overline{OE}) input is used to disable the outputs so the buses are effectively isolated.

The SN54SLC8T245-SEP device is designed so the control pins (DIR and \overline{OE}) are referenced to V_{CCA}.

This device is fully specified for partial-power-down applications using I_{off}. The I_{off} circuitry disables the outputs when the device is powered down. This inhibits current backflow into the device which prevents damage to the device.

The V_{CC} isolation feature is designed so that if either V_{CC} input supply is below 100 mV, all level shifter outputs are disabled and placed into a high-impedance state.

To put the level shifter I/Os in the high-impedance state during power up or power down, tie \overline{OE} to V_{CCA} through a pullup resistor; the current-sinking capability of the driver determines the minimum value of the resistor.

Package Information

PART NUMBER	PACKAGE ⁽¹⁾	PACKAGE SIZE ⁽²⁾
SN54SLC8T245-SEP	PW (TSSOP, 24)	7.8 mm × 6.4 mm

(1) For more information, see [Section 11](#).

(2) The package size (length × width) is a nominal value and includes pins, where applicable.



Table of Contents

1 Features	1	7 Detailed Description	11
2 Applications	1	7.1 Overview.....	11
3 Description	1	7.2 Functional Block Diagram.....	11
4 Pin Configuration and Functions	3	7.3 Feature Description.....	12
5 Specifications	4	7.4 Device Functional Modes.....	12
5.1 Absolute Maximum Ratings.....	4	8 Application and Implementation	13
5.2 ESD Ratings.....	4	8.1 Application Information.....	13
5.3 Recommended Operating Conditions.....	5	8.2 Typical Application.....	13
5.4 Thermal Information.....	5	8.3 Power Supply Recommendations.....	14
5.5 Electrical Characteristics.....	6	8.4 Layout.....	15
5.6 Switching Characteristics, $V_{CCA} = 0.7\text{ V}$	7	9 Device and Documentation Support	16
5.7 Switching Characteristics, $V_{CCA} = 0.8\text{ V}$	7	9.1 Documentation Support.....	16
5.8 Switching Characteristics, $V_{CCA} = 0.9\text{ V}$	7	9.2 Receiving Notification of Documentation Updates... 16	
5.9 Switching Characteristics, $V_{CCA} = 1.2\text{ V}$	8	9.3 Support Resources.....	16
5.10 Switching Characteristics, $V_{CCA} = 1.5\text{ V}$	8	9.4 Trademarks.....	16
5.11 Switching Characteristics, $V_{CCA} = 1.8\text{ V}$	8	9.5 Electrostatic Discharge Caution.....	16
5.12 Switching Characteristics, $V_{CCA} = 2.5\text{ V}$	9	10 Revision History	16
5.13 Switching Characteristics, $V_{CCA} = 3.3\text{ V}$	9	11 Mechanical, Packaging, and Orderable Information	16
5.14 Operating Characteristics.....	9		
6 Parameter Measurement Information	10		

4 Pin Configuration and Functions

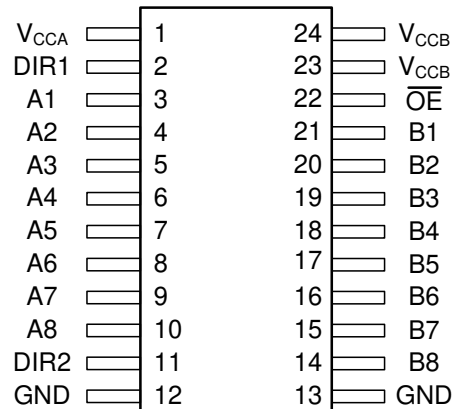

Figure 4-1. PW Package, 24-Pin TSSOP (Top View)

Table 4-1. Pin Functions

PIN		TYPE ⁽¹⁾	DESCRIPTION
NAME	NO.		
A1	3	I/O	Input/output A1. Referenced to V _{CCA} .
A2	4	I/O	Input/output A2. Referenced to V _{CCA} .
A3	5	I/O	Input/output A3. Referenced to V _{CCA} .
A4	6	I/O	Input/output A4. Referenced to V _{CCA} .
A5	7	I/O	Input/output A5. Referenced to V _{CCA} .
A6	8	I/O	Input/output A6. Referenced to V _{CCA} .
A7	9	I/O	Input/output A7. Referenced to V _{CCA} .
A8	10	I/O	Input/output A8. Referenced to V _{CCA} .
B1	21	I/O	Input/output B1. Referenced to V _{CCB} .
B2	20	I/O	Input/output B2. Referenced to V _{CCB} .
B3	19	I/O	Input/output B3. Referenced to V _{CCB} .
B4	18	I/O	Input/output B4. Referenced to V _{CCB} .
B5	17	I/O	Input/output B5. Referenced to V _{CCB} .
B6	16	I/O	Input/output B6. Referenced to V _{CCB} .
B7	15	I/O	Input/output B7. Referenced to V _{CCB} .
B8	14	I/O	Input/output B8. Referenced to V _{CCB} .
DIR1	2	I	Direction-control signal 1. Referenced to V _{CCA} .
DIR2	11	I	Direction-control signal 2. Referenced to V _{CCA} . Tie to GND to maintain backward compatibility with SN74AVC8T245 device.
GND	12	—	Ground
	13	—	Ground
OE	22	I	Output Enable. Pull to GND to enable all outputs. Pull to V _{CCA} to place all outputs in high-impedance mode. Referenced to V _{CCA} .
V _{CCA}	1	—	A-port supply voltage. 0.65 V ≤ V _{CCA} ≤ 3.6 V
V _{CCB}	23	—	B-port supply voltage. 0.65 V ≤ V _{CCB} ≤ 3.6 V
	24	—	B-port supply voltage. 0.65 V ≤ V _{CCB} ≤ 3.6 V

(1) I = input, O = output

5 Specifications

5.1 Absolute Maximum Ratings

over operating free-air temperature range (unless otherwise noted)⁽¹⁾

		MIN	MAX	UNIT
Supply voltage, V_{CCA}		-0.5	4.2	V
Supply voltage, V_{CCB}		-0.5	4.2	V
Input voltage, V_I ⁽²⁾	I/O ports (A port)	-0.5	4.2	V
	I/O ports (B port)	-0.5	4.2	
	Control inputs	-0.5	4.2	
Voltage applied to any output in the high-impedance or power-off state, V_O ⁽²⁾	A port	-0.5	4.2	V
	B port	-0.5	4.2	
Voltage applied to any output in the high or low state, V_O ^{(2) (3)}	A port	-0.5	$V_{CCA} + 0.2$	V
	B port	-0.5	$V_{CCB} + 0.2$	
Input clamp current, I_{IK}	$V_I < 0$	-50		mA
Output clamp current, I_{OK}	$V_O < 0$	-50		mA
Continuous output current, I_O		-50	50	mA
Continuous current through V_{CCA} , V_{CCB} , or GND		-100	100	mA
Junction Temperature, T_J			150	°C
Storage temperature, T_{stg}		-65	150	°C

- (1) Operation outside the *Absolute Maximum Ratings* may cause permanent device damage. *Absolute Maximum Ratings* do not imply functional operation of the device at these or any other conditions beyond those listed under *Recommended Operating Conditions*. If briefly operating outside the *Recommended Operating Conditions* but within the *Absolute Maximum Ratings*, the device may not sustain damage, but it may not be fully functional. Operating the device in this manner may affect device reliability, functionality, performance, and shorten the device lifetime.
- (2) The input voltage and output negative-voltage ratings may be exceeded if the input and output current ratings are observed.
- (3) The output positive-voltage rating may be exceeded up to 4.2 V maximum if the output current rating is observed.

5.2 ESD Ratings

		VALUE	UNIT
$V_{(ESD)}$ Electrostatic discharge	Human-body model (HBM), per ANSI/ESDA/JEDEC JS-001 ⁽¹⁾	±8000	V
	Charged-device model (CDM), per ANSI/ESDA/JEDEC JS-002 ⁽²⁾	±1000	

- (1) JEDEC document JEP155 states that 500-V HBM allows safe manufacturing with a standard ESD control process.
- (2) JEDEC document JEP157 states that 250-V CDM allows safe manufacturing with a standard ESD control process.

5.3 Recommended Operating Conditions

over operating free-air temperature range (unless otherwise noted) ⁽¹⁾ ⁽²⁾ ⁽³⁾

		MIN	MAX	UNIT	
V _{CCA}	Supply voltage	0.65	3.6	V	
V _{CCB}	Supply voltage	0.65	3.6	V	
V _{IH}	High-level input voltage	Data inputs	V _{CCI} = 0.65 V – 0.75 V	V _{CCI} × 0.70	V
		V _{CCI} = 0.76 V – 1 V	V _{CCI} × 0.70		
		V _{CCI} = 1.1 V – 1.95 V	V _{CCI} × 0.65		
		V _{CCI} = 2.3 V – 2.7 V	1.6		
		V _{CCI} = 3 V – 3.6 V	2		
	Control inputs (DIR, OE) Referenced to V _{CCA}	V _{CCA} = 0.65 V – 0.75 V	V _{CCA} × 0.70		
		V _{CCA} = 0.76 V – 1 V	V _{CCA} × 0.70		
		V _{CCA} = 1.1 V – 1.95 V	V _{CCA} × 0.65		
		V _{CCA} = 2.3 V – 2.7 V	1.6		
		V _{CCA} = 3 V – 3.6 V	2		
V _{IL}	Low-level input voltage	Data inputs	V _{CCI} = 0.65 V – 0.75 V	V _{CCI} × 0.30	V
		V _{CCI} = 0.76 V – 1 V	V _{CCI} × 0.30		
		V _{CCI} = 1.1 V – 1.95 V	V _{CCI} × 0.35		
		V _{CCI} = 2.3 V – 2.7 V	0.7		
		V _{CCI} = 3 V – 3.6 V	0.8		
	Control inputs (DIR, OE) Referenced to V _{CCA}	V _{CCA} = 0.65 V – 0.75 V	V _{CCA} × 0.30		
		V _{CCA} = 0.76 V – 1 V	V _{CCA} × 0.30		
		V _{CCA} = 1.1 V – 1.95 V	V _{CCA} × 0.35		
		V _{CCA} = 2.3 V – 2.7 V	0.7		
		V _{CCA} = 3 V – 3.6 V	0.8		
V _I	Input voltage ⁽³⁾	0	3.6	V	
V _O	Output voltage	Active state	0	V _{CCO} ⁽²⁾	V
		Tri-state	0	3.6	
Δt/Δv	Input transition rise or fall rate		10	ns/V	
T _A	Operating free-air temperature	–55	125	°C	

(1) V_{CCI} is the V_{CC} associated with the input port.

(2) V_{CCO} is the V_{CC} associated with the output port.

(3) All unused data inputs of the device must be held at V_{CCI} or GND for proper device operation. See the [Implications of Slow or Floating CMOS Inputs](#) application report.

5.4 Thermal Information

THERMAL METRIC		SN54SLC8T245-SEP	UNIT
		PW (TSSOP)	
		24 PINS	
R _{θJA}	Junction-to-ambient thermal resistance	102.9	°C/W
R _{θJC(top)}	Junction-to-case (top) thermal resistance	45.9	°C/W
R _{θJB}	Junction-to-board thermal resistance	58.2	°C/W
ψ _{JT}	Junction-to-top characterization parameter	6.9	°C/W
ψ _{JB}	Junction-to-board characterization parameter	57.8	°C/W
R _{θJC(bot)}	Junction-to-case (bottom) thermal resistance	N/A	°C/W

5.5 Electrical Characteristics

Over recommended operating free-air temperature range (unless otherwise noted)⁽¹⁾

PARAMETER	TEST CONDITIONS	V _{CCA}	V _{CCB}	MIN	TYP ⁽²⁾	MAX	UNIT
V _{OH}	High-level output voltage V _I = V _{IH}	I _{OH} = -100 μA	0.7 V – 3.6 V	0.7 V – 3.6 V	V _{CCO} – 0.1		V
		I _{OH} = -50 μA	0.65 V	0.65 V	0.55		
		I _{OH} = -200 μA	0.76 V	0.76 V	0.58		
		I _{OH} = -500 μA	0.85 V	0.85 V	0.65		
		I _{OH} = -3 mA	1.1 V	1.1 V	0.85		
		I _{OH} = -6 mA	1.4 V	1.4 V	1.05		
		I _{OH} = -8 mA	1.65 V	1.65 V	1.2		
		I _{OH} = -9 mA	2.3 V	2.3 V	1.75		
		I _{OH} = -12 mA	3 V	3 V	2.3		
V _{OL}	Low-level output voltage V _I = V _{IL}	I _{OL} = 100 μA	0.7 V – 3.6 V	0.7 V – 3.6 V	0.1		V
		I _{OL} = 50 μA	0.65 V	0.65 V	0.1		
		I _{OL} = 200 μA	0.76 V	0.76 V	0.18		
		I _{OL} = 500 μA	0.85 V	0.85 V	0.2		
		I _{OL} = 3 mA	1.1 V	1.1 V	0.25		
		I _{OL} = 6 mA	1.4 V	1.4 V	0.35		
		I _{OL} = 8 mA	1.65 V	1.65 V	0.45		
		I _{OL} = 9 mA	2.3 V	2.3 V	0.55		
		I _{OL} = 12 mA	3 V	3 V	0.7		
I _I	Input leakage current	Control Inputs (DIR, \overline{OE}): V _I = V _{CCA} or GND	0.65 V – 3.6 V	0.65 V – 3.6 V	-1	1	μA
I _{off}	Partial power down current	A Port: V _I or V _O = 0 V – 3.6 V	0 V	0 V – 3.6 V	-35	55	μA
		B Port: V _I or V _O = 0 V – 3.6 V	0 V – 3.6 V	0 V	-35	55	
I _{OZ}	High-impedance state output current	A Port: V _O = V _{CCO} or GND, V _I = V _{CCI} or GND, \overline{OE} = V _{IH}	3.6 V	3.6 V	-8	8	μA
		B Port: V _O = V _{CCO} or GND, V _I = V _{CCI} or GND, \overline{OE} = V _{IH}	3.6 V	3.6 V	-8	8	
I _{CCA}	V _{CCA} supply current	V _I = V _{CCI} or GND, I _O = 0 mA	0.65 V – 3.6 V	0.65 V – 3.6 V	40		μA
			0 V	3.6 V	-12		
			3.6 V	0 V	35		
I _{CCB}	V _{CCB} supply current	V _I = V _{CCI} or GND, I _O = 0 mA	0.65 V – 3.6 V	0.65 V – 3.6 V	38		μA
			0 V	3.6 V	35		
			3.6 V	0 V	-12		
I _{CCA} + I _{CCB}	Combined supply current	V _I = V _{CCI} or GND, I _O = 0 mA	0.65 V – 3.6 V	0.65 V – 3.6 V	70		μA
C _i	Input capacitance	Control Inputs (DIR, \overline{OE}): V _I = 3.3 V or GND	3.3 V	3.3 V	4.5		pF
C _{io}	Data I/O capacitance	Ports A and B: \overline{OE} = V _{CCA} , V _O = 1.65 V DC + 1 MHz -16 dBm sine wave	3.3 V	3.3 V	5.7		pF

(1) V_{CCO} is the V_{CC} associated with the output port.

(2) All typical values are for T_A = 25°C

5.6 Switching Characteristics, $V_{CCA} = 0.7\text{ V}$

See [Figure 6-1](#) and [Figure 6-2](#) for test circuit and loading conditions. See [Figure 6-3](#) and [Figure 6-4](#) for measurement waveforms.

PARAMETER	TEST CONDITIONS	B-PORT SUPPLY VOLTAGE (V_{CCB})									UNIT
		$0.7\text{ V} \pm 0.05\text{ V}$	$0.8\text{ V} \pm 0.04\text{ V}$	$0.9\text{ V} \pm 0.045\text{ V}$	$1.2\text{ V} \pm 0.1\text{ V}$	$1.5\text{ V} \pm 0.1\text{ V}$	$1.8\text{ V} \pm 0.15\text{ V}$	$2.5\text{ V} \pm 0.2\text{ V}$	$3.3\text{ V} \pm 0.3\text{ V}$		
		TYP	TYP	TYP	TYP	TYP	TYP	TYP	TYP		
t_{pd}	Propagation delay	From input A to output B	68	47	34	23	21	21	23	27	ns
		From input B to output A	67	55	46	32	28	26	25	25	
t_{dis}	Disable time	From input \overline{OE} to output A	100	100	100	100	100	100	100	100	ns
		From input \overline{OE} to output B	111	86	73	38	34	34	33	36	
t_{en}	Enable time	From input \overline{OE} to output A	105	105	105	105	105	105	105	105	ns
		From input \overline{OE} to output B	127	78	56	39	36	36	39	47	

5.7 Switching Characteristics, $V_{CCA} = 0.8\text{ V}$

See [Figure 6-1](#) and [Figure 6-2](#) for test circuit and loading conditions. See [Figure 6-3](#) and [Figure 6-4](#) for measurement waveforms.

PARAMETER	TEST CONDITIONS	B-PORT SUPPLY VOLTAGE (V_{CCB})									UNIT
		$0.7\text{ V} \pm 0.05\text{ V}$	$0.8\text{ V} \pm 0.04\text{ V}$	$0.9\text{ V} \pm 0.045\text{ V}$	$1.2\text{ V} \pm 0.1\text{ V}$	$1.5\text{ V} \pm 0.1\text{ V}$	$1.8\text{ V} \pm 0.15\text{ V}$	$2.5\text{ V} \pm 0.2\text{ V}$	$3.3\text{ V} \pm 0.3\text{ V}$		
		TYP	TYP	TYP	TYP	TYP	TYP	TYP	TYP		
t_{pd}	Propagation delay	From input A to output B	55	38	26	16	14	13	13	14	ns
		From input B to output A	47	38	32	21	17	15	14	14	
t_{dis}	Disable time	From input \overline{OE} to output A	71	71	71	71	71	71	71	71	ns
		From input \overline{OE} to output B	105	79	66	32	28	27	25	26	
t_{en}	Enable time	From input \overline{OE} to output A	64	64	64	64	64	64	64	64	ns
		From input \overline{OE} to output B	118	69	47	30	27	26	26	28	

5.8 Switching Characteristics, $V_{CCA} = 0.9\text{ V}$

See [Figure 6-1](#) and [Figure 6-2](#) for test circuit and loading conditions. See [Figure 6-3](#) and [Figure 6-4](#) for measurement waveforms.

PARAMETER	TEST CONDITIONS	B-PORT SUPPLY VOLTAGE (V_{CCB})									UNIT
		$0.7\text{ V} \pm 0.05\text{ V}$	$0.8\text{ V} \pm 0.04\text{ V}$	$0.9\text{ V} \pm 0.045\text{ V}$	$1.2\text{ V} \pm 0.1\text{ V}$	$1.5\text{ V} \pm 0.1\text{ V}$	$1.8\text{ V} \pm 0.15\text{ V}$	$2.5\text{ V} \pm 0.2\text{ V}$	$3.3\text{ V} \pm 0.3\text{ V}$		
		TYP	TYP	TYP	TYP	TYP	TYP	TYP	TYP		
t_{pd}	Propagation delay	From input A to output B	45	31	21	13	10	9	9	9	ns
		From input B to output A	35	27	23	15	11	10	9	8	
t_{dis}	Disable time	From input \overline{OE} to output A	55	55	55	55	55	55	55	55	ns
		From input \overline{OE} to output B	99	74	61	26	23	22	20	20	
t_{en}	Enable time	From input \overline{OE} to output A	41	41	41	41	41	41	41	41	ns
		From input \overline{OE} to output B	108	63	41	24	20	19	18	19	

5.9 Switching Characteristics, $V_{CCA} = 1.2\text{ V}$

See Figure 6-1 and Figure 6-2 for test circuit and loading conditions. See Figure 6-3 and Figure 6-4 for measurement waveforms.

PARAMETER	TEST CONDITIONS	B-PORT SUPPLY VOLTAGE (V_{CCB})								UNIT	
		0.7 V ± 0.05 V	0.8 V ± 0.04 V	0.9 V ± 0.045 V	1.2 V ± 0.1 V	1.5 V ± 0.1 V	1.8 V ± 0.15 V	2.5 V ± 0.2 V	3.3 V ± 0.3 V		
		TYP	TYP	TYP	TYP	TYP	TYP	TYP	TYP		
t_{pd}	Propagation delay	From input A to output B	33	21	14	8	6	5	5	5	ns
		From input B to output A	24	16	13	8	6	5	4	4	
t_{dis}	Disable time	From input \overline{OE} to output A	19	19	19	19	19	19	19	19	ns
		From input \overline{OE} to output B	92	66	53	20	17	16	14	14	
t_{en}	Enable time	From input \overline{OE} to output A	19	19	19	19	19	19	19	19	ns
		From input \overline{OE} to output B	96	53	33	17	12	11	10	10	

5.10 Switching Characteristics, $V_{CCA} = 1.5\text{ V}$

See Figure 6-1 and Figure 6-2 for test circuit and loading conditions. See Figure 6-3 and Figure 6-4 for measurement waveforms.

PARAMETER	TEST CONDITIONS	B-PORT SUPPLY VOLTAGE (V_{CCB})								UNIT	
		0.7 V ± 0.05 V	0.8 V ± 0.04 V	0.9 V ± 0.045 V	1.2 V ± 0.1 V	1.5 V ± 0.1 V	1.8 V ± 0.15 V	2.5 V ± 0.2 V	3.3 V ± 0.3 V		
		TYP	TYP	TYP	TYP	TYP	TYP	TYP	TYP		
t_{pd}	Propagation delay	From input A to output B	29	17	11	6	5	4	4	3	ns
		From input B to output A	23	14	10	6	5	4	3	3	
t_{dis}	Disable time	From input \overline{OE} to output A	15	15	15	15	15	15	15	15	ns
		From input \overline{OE} to output B	89	64	50	18	15	15	12	13	
t_{en}	Enable time	From input \overline{OE} to output A	12	12	12	12	12	12	12	12	ns
		From input \overline{OE} to output B	92	49	29	14	10	8	7	7	

5.11 Switching Characteristics, $V_{CCA} = 1.8\text{ V}$

See Figure 6-1 and Figure 6-2 for test circuit and loading conditions. See Figure 6-3 and Figure 6-4 for measurement waveforms.

PARAMETER	TEST CONDITIONS	B-PORT SUPPLY VOLTAGE (V_{CCB})								UNIT	
		0.7 V ± 0.05 V	0.8 V ± 0.04 V	0.9 V ± 0.045 V	1.2 V ± 0.1 V	1.5 V ± 0.1 V	1.8 V ± 0.15 V	2.5 V ± 0.2 V	3.3 V ± 0.3 V		
		TYP	TYP	TYP	TYP	TYP	TYP	TYP	TYP		
t_{pd}	Propagation delay	From input A to output B	28	15	9	5	4	4	3	3	ns
		From input B to output A	23	13	9	5	4	4	3	2	
t_{dis}	Disable time	From input \overline{OE} to output A	14	14	14	14	14	14	14	14	ns
		From input \overline{OE} to output B	89	63	49	17	15	14	12	12	
t_{en}	Enable time	From input \overline{OE} to output A	9	9	9	9	9	9	9	9	ns
		From input \overline{OE} to output B	91	47	28	13	9	7	6	6	

5.12 Switching Characteristics, $V_{CCA} = 2.5\text{ V}$

See [Figure 6-1](#) and [Figure 6-2](#) for test circuit and loading conditions. See [Figure 6-3](#) and [Figure 6-4](#) for measurement waveforms.

PARAMETER	TEST CONDITIONS	B-PORT SUPPLY VOLTAGE (V_{CCB})								UNIT	
		0.7 V ± 0.05 V	0.8 V ± 0.04 V	0.9 V ± 0.045 V	1.2 V ± 0.1 V	1.5 V ± 0.1 V	1.8 V ± 0.15 V	2.5 V ± 0.2 V	3.3 V ± 0.3 V		
		TYP	TYP	TYP	TYP	TYP	TYP	TYP	TYP		
t_{pd}	Propagation delay	From input A to output B	27	14	8	4	3	3	2	2	ns
		From input B to output A	26	13	8	5	4	3	2	2	
t_{dis}	Disable time	From input \overline{OE} to output A	11	11	11	11	11	11	11	11	ns
		From input \overline{OE} to output B	88	62	48	16	13	13	11	11	
t_{en}	Enable time	From input \overline{OE} to output A	6	6	6	6	6	6	6	6	ns
		From input \overline{OE} to output B	89	46	26	12	8	7	5	5	

5.13 Switching Characteristics, $V_{CCA} = 3.3\text{ V}$

See [Figure 6-1](#) and [Figure 6-2](#) for test circuit and loading conditions. See [Figure 6-3](#) and [Figure 6-4](#) for measurement waveforms.

PARAMETER	TEST CONDITIONS	B-PORT SUPPLY VOLTAGE (V_{CCB})								UNIT	
		0.7 V ± 0.05 V	0.8 V ± 0.04 V	0.9 V ± 0.045 V	1.2 V ± 0.1 V	1.5 V ± 0.1 V	1.8 V ± 0.15 V	2.5 V ± 0.2 V	3.3 V ± 0.3 V		
		TYP	TYP	TYP	TYP	TYP	TYP	TYP	TYP		
t_{pd}	Propagation delay	From input A to output B	27	13	8	4	3	2	2	2	ns
		From input B to output A	31	14	9	5	3	3	2	2	
t_{dis}	Disable time	From input \overline{OE} to output A	11	11	11	11	11	11	11	11	ns
		From input \overline{OE} to output B	87	61	48	16	13	12	11	11	
t_{en}	Enable time	From input \overline{OE} to output A	5	5	5	5	5	5	5	5	ns
		From input \overline{OE} to output B	89	45	26	11	8	6	5	4	

5.14 Operating Characteristics

$T_A = 25^\circ\text{C}$, $C_L = 0$, $R_L = \text{Open}$, $f = 1\text{ MHz}$, $t_r = t_f = 1\text{ ns}$

PARAMETER	TEST CONDITIONS	SUPPLY VOLTAGE ($V_{CCA} = V_{CCB}$)								UNIT
		0.7 V	0.8 V	0.9 V	1.2 V	1.5 V	1.8 V	2.5 V	3.3 V	
		TYP	TYP	TYP	TYP	TYP	TYP	TYP	TYP	
C_{pdA}	V_{CCA} Power dissipation capacitance per transceiver									
	A to B: Outputs Enabled	1.2	1.8	1.8	1.7	1.7	1.7	2	2.5	pF
	A to B: Outputs Disabled	1.1	1.8	1.8	1.7	1.7	1.7	2	2.1	pF
	B to A: Outputs Enabled	9.3	11.8	11.8	12	12.2	13	16.4	18.1	pF
C_{pdB}	V_{CCB} Power dissipation capacitance per transceiver									
	A to B: Outputs Enabled	9.3	11.7	11.8	11.9	12.2	12.9	16.3	18	pF
	A to B: Outputs Disabled	2.6	11.7	11.8	11.9	12.2	12.9	16.3	3.9	pF
	B to A: Outputs Enabled	1.2	1.8	1.8	1.7	1.7	1.7	2	2.5	pF
	B to A: Outputs Disabled	1.1	1.8	1.8	1.7	1.7	1.7	2	2.1	pF

6 Parameter Measurement Information

Unless otherwise noted, all input pulses are supplied by generators having the following characteristics:

- $f = 1 \text{ MHz}$
- $Z_0 = 50 \Omega$
- $dv / dt \leq 1 \text{ ns/V}$

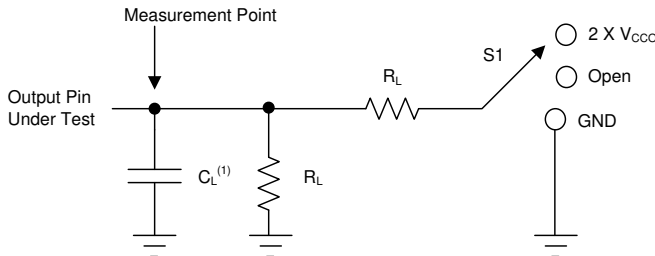

A. C_L includes probe and jig capacitance.

Figure 6-1. Load Circuit

Parameter	V_{CCO}	R_L	C_L	S1	V_{TP}
t_{pd}	1.1 V - 3.6 V	2 k Ω	15 pF	Open	N/A
	0.65 V - 0.95 V	20 k Ω	15 pF	Open	N/A
$t_{en}^{(1)}, t_{dis}^{(1)}$	3 V - 3.6 V	2 k Ω	15 pF	2 X V_{CCO}	0.3 V
	1.65 V - 2.7 V	2 k Ω	15 pF	2 X V_{CCO}	0.15 V
	1.1 V - 1.6 V	2 k Ω	15 pF	2 X V_{CCO}	0.1 V
	0.65 V - 0.95 V	20 k Ω	15 pF	2 X V_{CCO}	0.1 V
$t_{en}^{(2)}, t_{dis}^{(2)}$	3 V - 3.6 V	2 k Ω	15 pF	GND	0.3 V
	1.65 V - 2.7 V	2 k Ω	15 pF	GND	0.15 V
	1.1 V - 1.6 V	2 k Ω	15 pF	GND	0.1 V
	0.65 V - 0.95 V	20 k Ω	15 pF	GND	0.1 V

- A. Output waveform on the conditions that input is driven to a valid Logic Low.
 B. Output waveform on the condition that input is driven to a valid Logic High.

Figure 6-2. Load Circuit Conditions

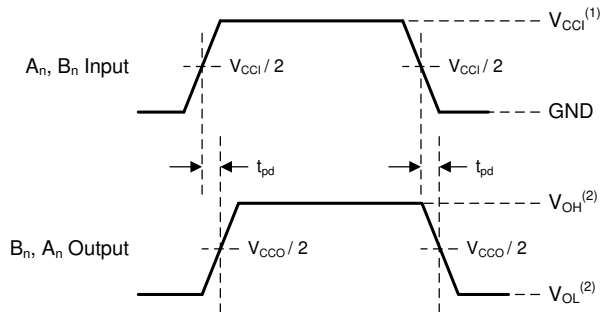

- A. V_{CCI} is the supply pin associated with the input port.
 B. V_{OH} and V_{OL} are typical output voltage levels with specified R_L , C_L , and S_1 .

Figure 6-3. Propagation Delay

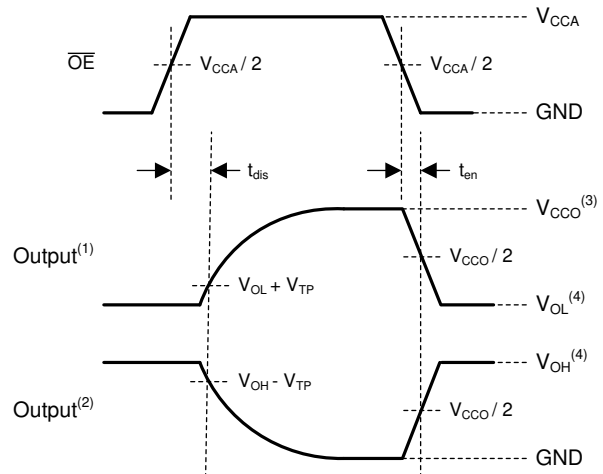

- A. Output waveform on the condition that input is driven to a valid Logic Low.
 B. Output waveform on the condition that input is driven to a valid Logic High.
 C. V_{CCO} is the supply pin associated with the output port.
 D. V_{OH} and V_{OL} are typical output voltage levels with specified R_L , C_L , and S_1 .

Figure 6-4. Enable Time And Disable Time

7 Detailed Description

7.1 Overview

The SN54SLC8T245-SEP device is an 8-bit, dual-supply non-inverting transceiver with bidirectional voltage level translation. The I/O pins labeled with A and the control pins (DIR1, DIR2, and \overline{OE}) are supported by V_{CCA} , and the I/O pins labeled with B are supported by V_{CCB} . The A port and the B port are able to accept I/O voltages ranging from 0.65 V to 3.6 V.

7.2 Functional Block Diagram

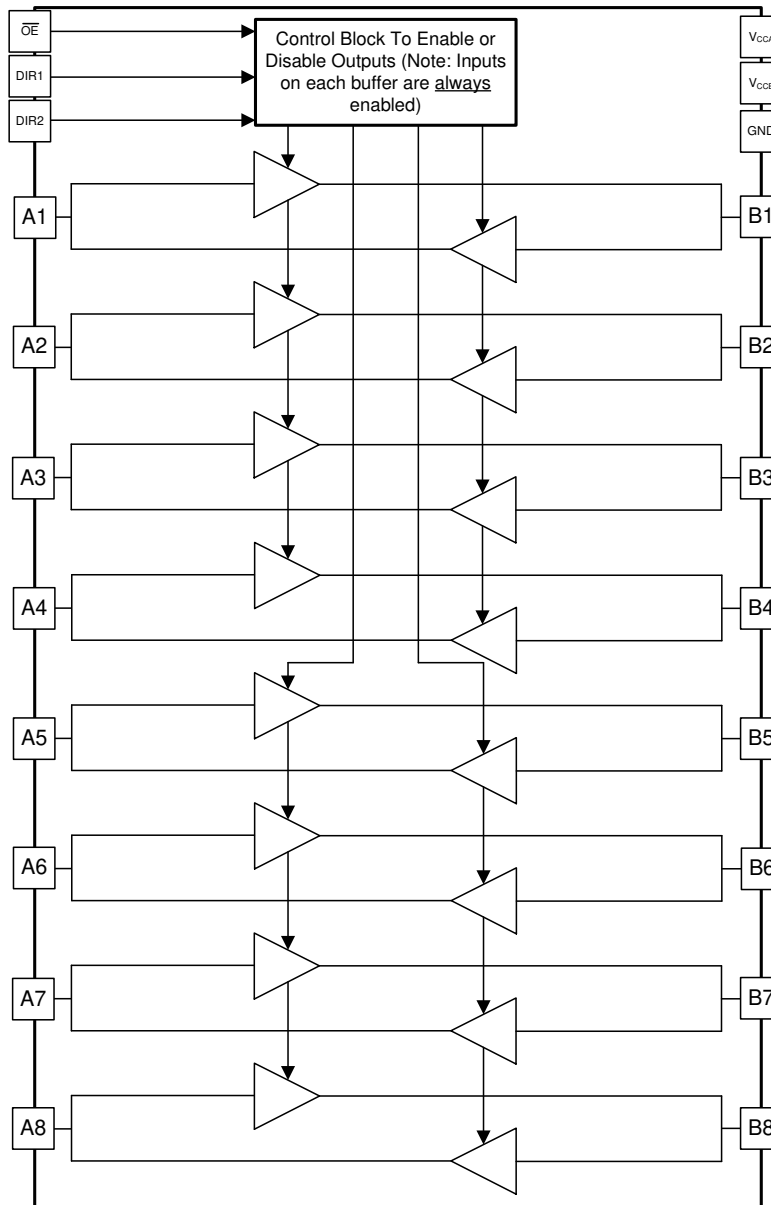

7.3 Feature Description

7.3.1 Up-Translation and Down-Translation From 0.65 V to 3.6 V

Both supply pins are configured from 0.65 V to 3.6 V, which makes the device suitable for translating between any of the low voltage nodes (0.7 V, 0.8 V, 0.9 V, 1.2 V, 1.8 V, 2.5 V, and 3.3 V).

7.3.2 Multiple Direction Control Pins

Two control pins are used to configure the 8 data I/Os. I/O channels 1 through 4 are grouped together and I/O channels 5 through 8 are banked together. The benefit of this is to permit simultaneous up-translation and down-translation within one device. This eliminates the need for multiple devices, where each device can only provide up-translation or down-translation sequentially. Simultaneous up and down translation is supported when both V_{CCA} and V_{CCB} are at least 1.40 V.

7.3.3 I_{off} Supports Partial-Power-Down Mode Operation

This feature is to limit the leakage current of an I/O pin being driven to a voltage as large as 3.6 V while having its corresponding power supply rail powered down. This is represented by the I_{off} parameter in the [Electrical Characteristics](#) table.

7.4 Device Functional Modes

All control inputs are referenced to V_{CCA} and must be driven to a valid Logic High or Logic Low (that is, not floating) for proper device operation and to prevent excessive power consumption. [Table 7-1](#) summarizes the possible modes of device operation based on the configuration of the control inputs.

Table 7-1. Function Table

CONTROL INPUTS ⁽¹⁾			SIGNAL DIRECTION	
\overline{OE}	DIR1	DIR2	Bits 1:4	Bits 5:8
H	X	X	Disabled (Hi-Z)	
L	L	L	B to A	
L	L	H	B to A	A to B
L	H	L	A to B	
L	H	H	A to B	B to A

(1) Input circuits of the data I/Os are always active and must be driven to a valid logic level.

8 Application and Implementation

Note

Information in the following applications sections is not part of the TI component specification, and TI does not warrant its accuracy or completeness. TI's customers are responsible for determining suitability of components for their purposes, as well as validating and testing their design implementation to confirm system functionality.

8.1 Application Information

The SN54SLC8T245-SEP device can be used in level-translation applications for interfacing devices or systems operating at different voltage nodes. Figure 8-1 depicts an application in which the SN54SLC8T245-SEP device is up-translating a 0.7 V input to a 3.3 V output to interface between a system controller and a peripheral device.

8.2 Typical Application

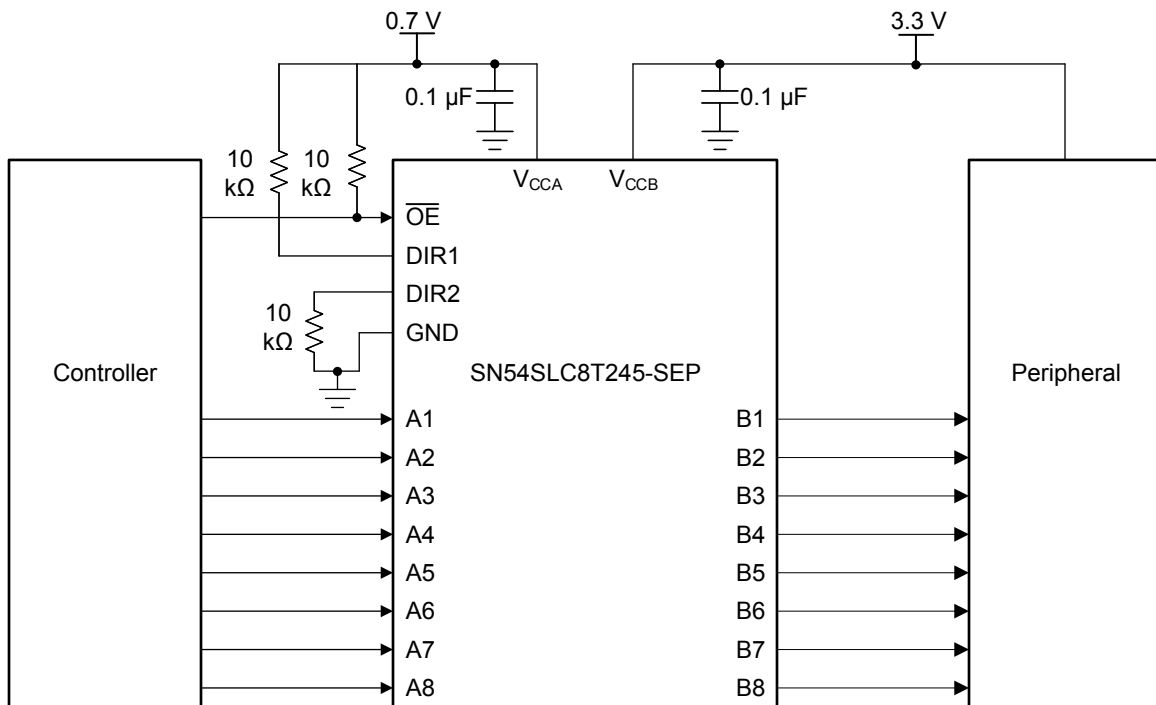

Figure 8-1. Typical Application Schematic

8.2.1 Design Requirements

For this design example, use the parameters listed in [Table 8-1](#).

Table 8-1. Design Parameters

DESIGN PARAMETERS	EXAMPLE VALUE
Input voltage range	0.65 V to 3.6 V
Output voltage range	0.65 V to 3.6 V

8.2.2 Detailed Design Procedure

To begin the design process, determine the following:

- Input voltage range
 - Use the supply voltage of the device that is driving the SN54SLC8T245-SEP device to determine the input voltage range. For a valid logic high, the value must exceed the V_{IH} of the input port. For a valid logic low, the value must be less than the V_{IL} of the input port.
- Output voltage range
 - Use the supply voltage of the device that the SN54SLC8T245-SEP device is driving to determine the output voltage range.

8.2.3 Application Curve

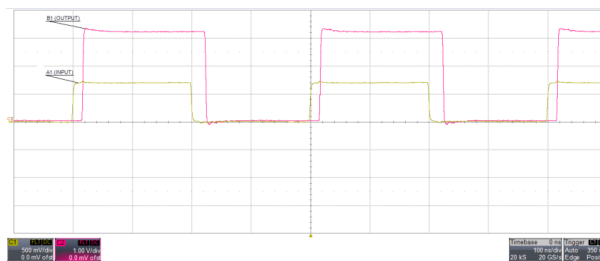

Figure 8-2. Translation Up (0.7 V to 3.3 V) at 2.5 MHz

8.3 Power Supply Recommendations

Always apply a ground reference to the GND pins first. There are no additional requirements for power supply sequencing.

This device was designed with various power supply sequencing methods in mind to help prevent unintended triggering of downstream devices. For more information regarding the power up glitch performance of level translators, see the [Power Sequencing for AXC Family of Devices](#) application report.

8.4 Layout

8.4.1 Layout Guidelines

To device reliability, follow common printed-circuit board layout guidelines:

- Use bypass capacitors on power supplies.
- Use short trace lengths to avoid excessive loading.
- Place pads on the signal paths for loading capacitors or pullup resistors to help adjust rise and fall times of signals depending on the system requirements.

8.4.2 Layout Example

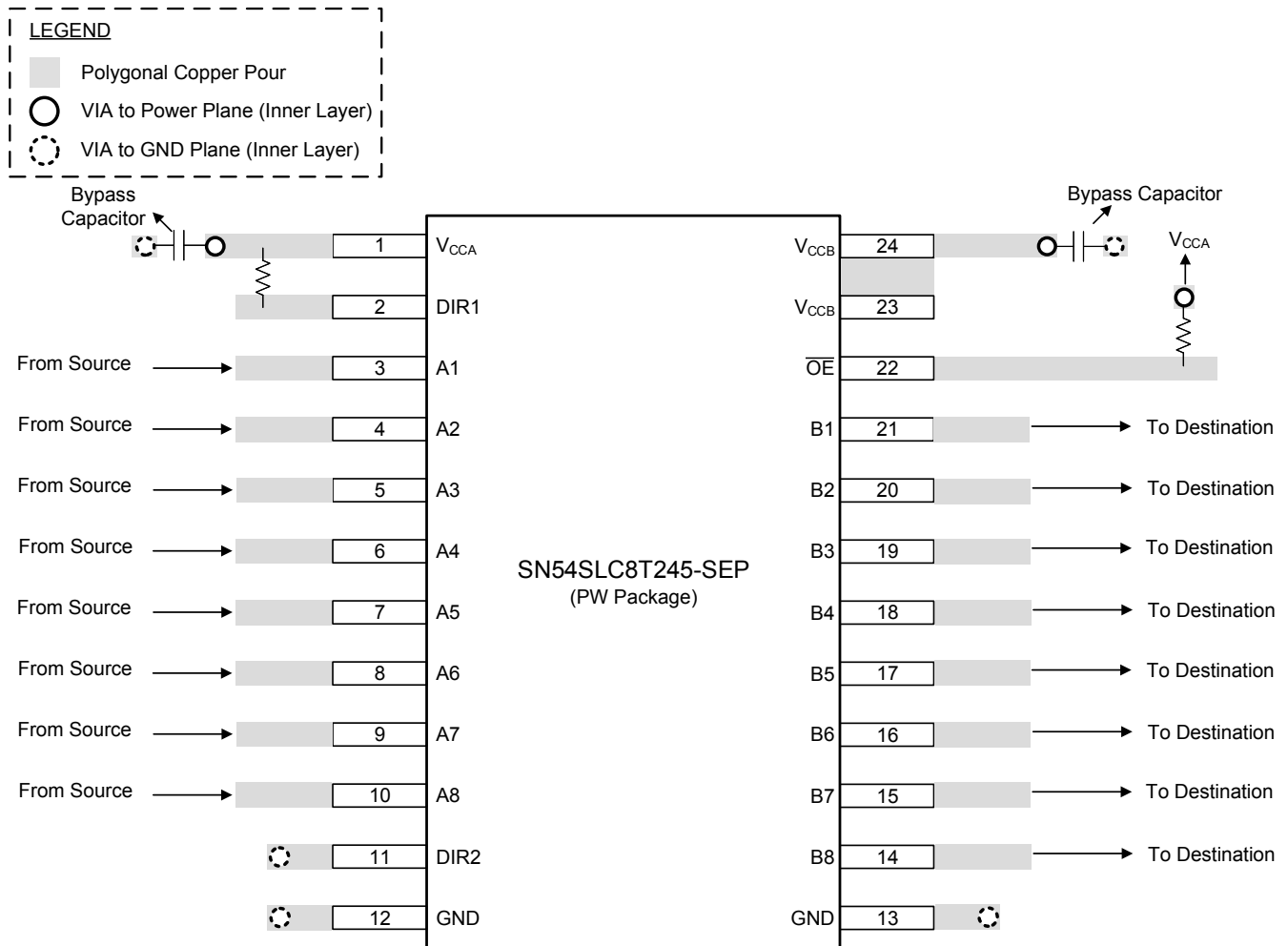

Figure 8-3. SN54SLC8T245-SEP Device Layout Example

9 Device and Documentation Support

9.1 Documentation Support

9.1.1 Related Documentation

For related documentation, see the following:

- Texas Instruments, [Implications of Slow or Floating CMOS Inputs application report](#)

9.2 Receiving Notification of Documentation Updates

To receive notification of documentation updates, navigate to the device product folder on [ti.com](#). Click on *Subscribe to updates* to register and receive a weekly digest of any product information that has changed. For change details, review the revision history included in any revised document.

9.3 Support Resources

TI E2E™ [support forums](#) are an engineer's go-to source for fast, verified answers and design help — straight from the experts. Search existing answers or ask your own question to get the quick design help you need.

Linked content is provided "AS IS" by the respective contributors. They do not constitute TI specifications and do not necessarily reflect TI's views; see TI's [Terms of Use](#).

9.4 Trademarks

TI E2E™ is a trademark of Texas Instruments.

All trademarks are the property of their respective owners.

9.5 Electrostatic Discharge Caution



This integrated circuit can be damaged by ESD. Texas Instruments recommends that all integrated circuits be handled with appropriate precautions. Failure to observe proper handling and installation procedures can cause damage.

ESD damage can range from subtle performance degradation to complete device failure. Precision integrated circuits may be more susceptible to damage because very small parametric changes could cause the device not to meet its published specifications.

10 Revision History

NOTE: Page numbers for previous revisions may differ from page numbers in the current version.

Changes from Revision A (September 2022) to Revision B (December 2023)	Page
• Updated the <i>Package Information</i> table to include package lead size.....	1
• Updated the <i>Translation Up (0.7 V to 3.3 V) at 2.5 MHz</i> figure.....	14

Changes from Revision * (February 2022) to Revision A (September 2022)	Page
• Changed the status of the data sheet from: <i>Advanced Information</i> to: <i>Production Data</i>	1

11 Mechanical, Packaging, and Orderable Information

The following pages include mechanical, packaging, and orderable information. This information is the most current data available for the designated devices. This data is subject to change without notice and revision of this document. For browser-based versions of this data sheet, refer to the left-hand navigation.

PACKAGING INFORMATION

Orderable Device	Status (1)	Package Type	Package Drawing	Pins	Package Qty	Eco Plan (2)	Lead finish/ Ball material (6)	MSL Peak Temp (3)	Op Temp (°C)	Device Marking (4/5)	Samples
SN54SLC8T245PWTSEP	ACTIVE	TSSOP	PW	24	250	RoHS & Green	NIPDAU	Level-1-260C-UNLIM	-55 to 125	SLC8T245E	Samples
V62/22604-01XE	ACTIVE	TSSOP	PW	24	250	RoHS & Green	NIPDAU	Level-1-260C-UNLIM		SLC8T245E	Samples

(1) The marketing status values are defined as follows:

ACTIVE: Product device recommended for new designs.

LIFEBUY: TI has announced that the device will be discontinued, and a lifetime-buy period is in effect.

NRND: Not recommended for new designs. Device is in production to support existing customers, but TI does not recommend using this part in a new design.

PREVIEW: Device has been announced but is not in production. Samples may or may not be available.

OBSOLETE: TI has discontinued the production of the device.

(2) **RoHS:** TI defines "RoHS" to mean semiconductor products that are compliant with the current EU RoHS requirements for all 10 RoHS substances, including the requirement that RoHS substance do not exceed 0.1% by weight in homogeneous materials. Where designed to be soldered at high temperatures, "RoHS" products are suitable for use in specified lead-free processes. TI may reference these types of products as "Pb-Free".

RoHS Exempt: TI defines "RoHS Exempt" to mean products that contain lead but are compliant with EU RoHS pursuant to a specific EU RoHS exemption.

Green: TI defines "Green" to mean the content of Chlorine (Cl) and Bromine (Br) based flame retardants meet JS709B low halogen requirements of <=1000ppm threshold. Antimony trioxide based flame retardants must also meet the <=1000ppm threshold requirement.

(3) MSL, Peak Temp. - The Moisture Sensitivity Level rating according to the JEDEC industry standard classifications, and peak solder temperature.

(4) There may be additional marking, which relates to the logo, the lot trace code information, or the environmental category on the device.

(5) Multiple Device Markings will be inside parentheses. Only one Device Marking contained in parentheses and separated by a "~" will appear on a device. If a line is indented then it is a continuation of the previous line and the two combined represent the entire Device Marking for that device.

(6) Lead finish/Ball material - Orderable Devices may have multiple material finish options. Finish options are separated by a vertical ruled line. Lead finish/Ball material values may wrap to two lines if the finish value exceeds the maximum column width.

Important Information and Disclaimer:The information provided on this page represents TI's knowledge and belief as of the date that it is provided. TI bases its knowledge and belief on information provided by third parties, and makes no representation or warranty as to the accuracy of such information. Efforts are underway to better integrate information from third parties. TI has taken and continues to take reasonable steps to provide representative and accurate information but may not have conducted destructive testing or chemical analysis on incoming materials and chemicals. TI and TI suppliers consider certain information to be proprietary, and thus CAS numbers and other limited information may not be available for release.

In no event shall TI's liability arising out of such information exceed the total purchase price of the TI part(s) at issue in this document sold by TI to Customer on an annual basis.

TAPE AND REEL INFORMATION

QUADRANT ASSIGNMENTS FOR PIN 1 ORIENTATION IN TAPE

*All dimensions are nominal

Device	Package Type	Package Drawing	Pins	SPQ	Reel Diameter (mm)	Reel Width W1 (mm)	A0 (mm)	B0 (mm)	K0 (mm)	P1 (mm)	W (mm)	Pin1 Quadrant
SN54SLC8T245PWTSEP	TSSOP	PW	24	250	180.0	16.4	6.95	8.3	1.6	8.0	16.0	Q1

TAPE AND REEL BOX DIMENSIONS



*All dimensions are nominal

Device	Package Type	Package Drawing	Pins	SPQ	Length (mm)	Width (mm)	Height (mm)
SN54SLC8T245PWTSEP	TSSOP	PW	24	250	210.0	185.0	35.0

EXAMPLE BOARD LAYOUT

PW0024A

TSSOP - 1.2 mm max height

SMALL OUTLINE PACKAGE

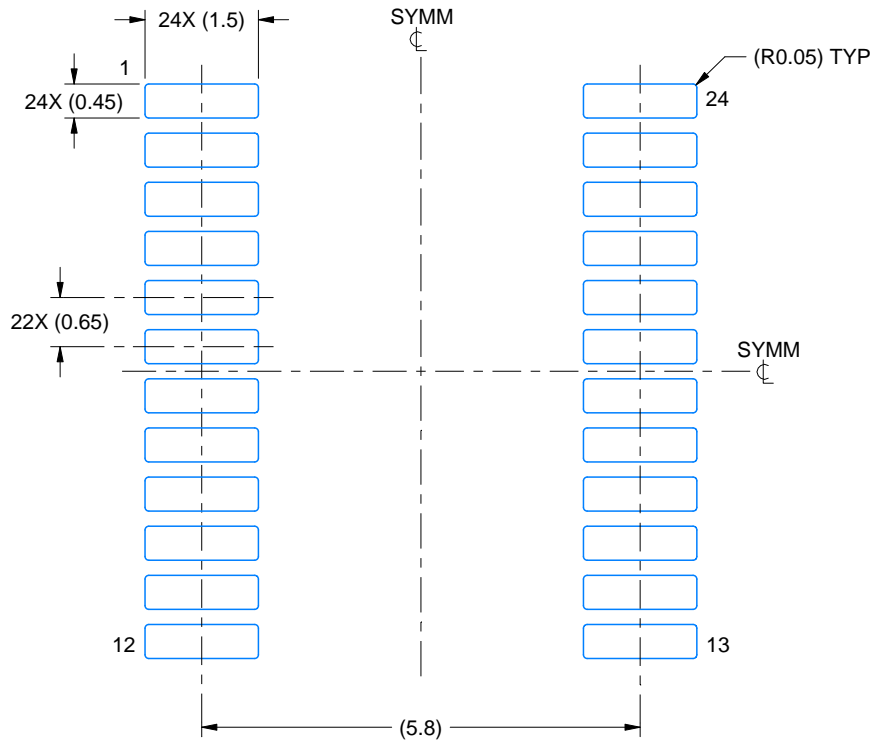

LAND PATTERN EXAMPLE
EXPOSED METAL SHOWN
SCALE: 10X

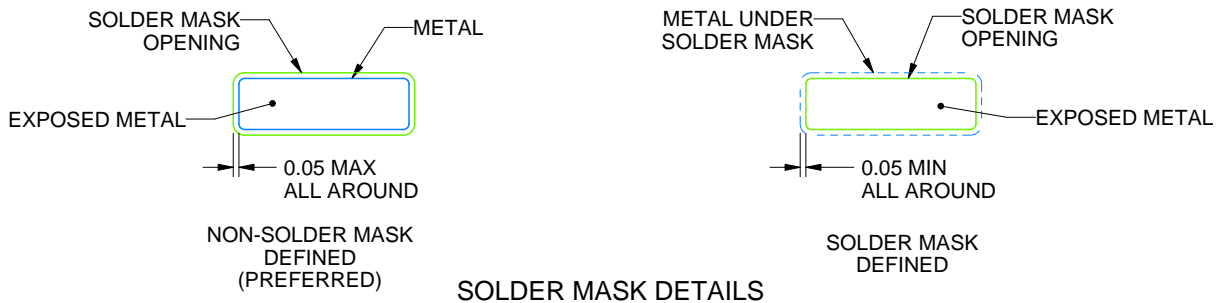

SOLDER MASK DETAILS

4220208/A 02/2017

NOTES: (continued)

6. Publication IPC-7351 may have alternate designs.
7. Solder mask tolerances between and around signal pads can vary based on board fabrication site.

EXAMPLE STENCIL DESIGN

PW0024A

TSSOP - 1.2 mm max height

SMALL OUTLINE PACKAGE

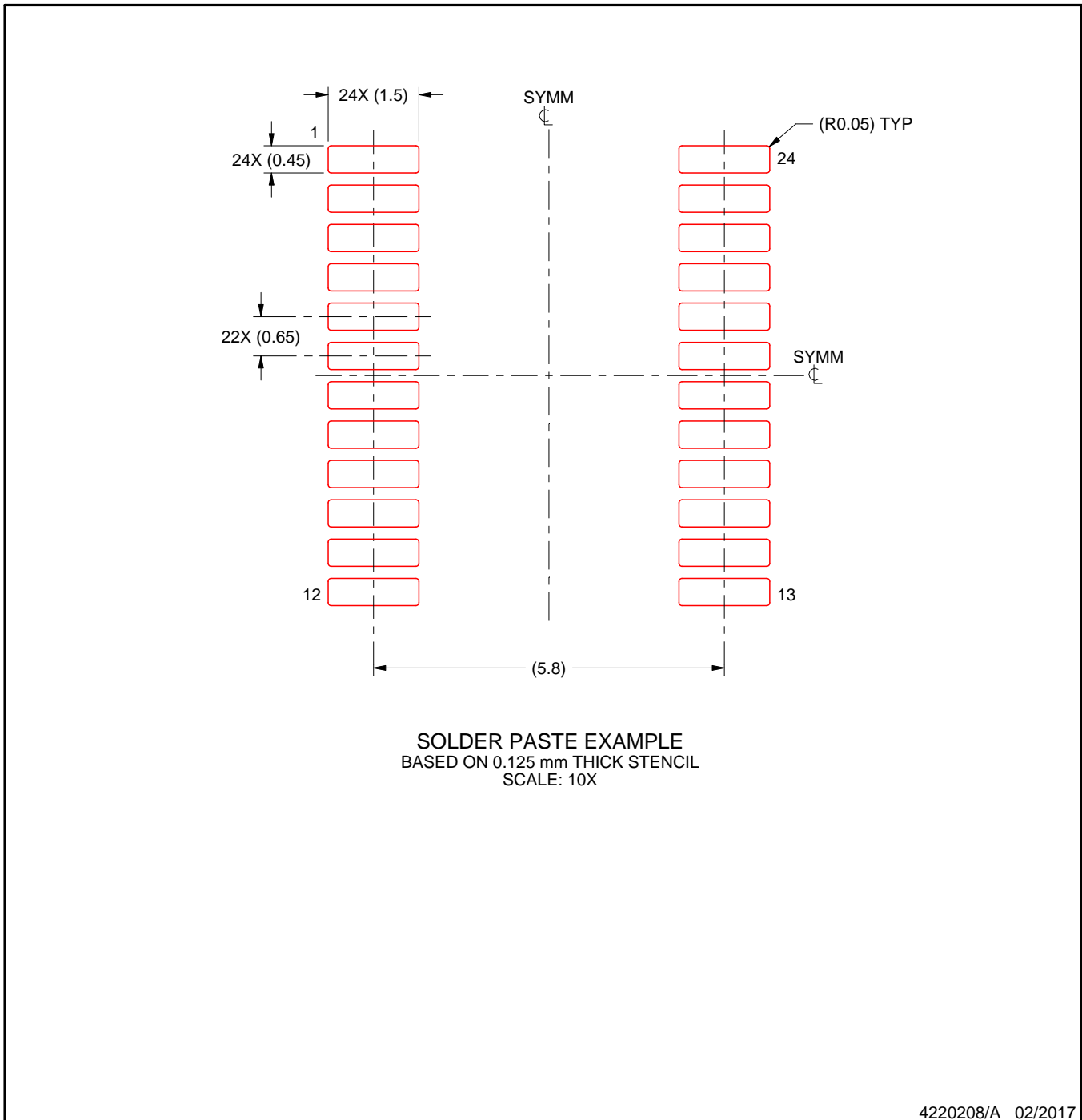

NOTES: (continued)

8. Laser cutting apertures with trapezoidal walls and rounded corners may offer better paste release. IPC-7525 may have alternate design recommendations.
9. Board assembly site may have different recommendations for stencil design.

IMPORTANT NOTICE AND DISCLAIMER

TI PROVIDES TECHNICAL AND RELIABILITY DATA (INCLUDING DATA SHEETS), DESIGN RESOURCES (INCLUDING REFERENCE DESIGNS), APPLICATION OR OTHER DESIGN ADVICE, WEB TOOLS, SAFETY INFORMATION, AND OTHER RESOURCES "AS IS" AND WITH ALL FAULTS, AND DISCLAIMS ALL WARRANTIES, EXPRESS AND IMPLIED, INCLUDING WITHOUT LIMITATION ANY IMPLIED WARRANTIES OF MERCHANTABILITY, FITNESS FOR A PARTICULAR PURPOSE OR NON-INFRINGEMENT OF THIRD PARTY INTELLECTUAL PROPERTY RIGHTS.

These resources are intended for skilled developers designing with TI products. You are solely responsible for (1) selecting the appropriate TI products for your application, (2) designing, validating and testing your application, and (3) ensuring your application meets applicable standards, and any other safety, security, regulatory or other requirements.

These resources are subject to change without notice. TI grants you permission to use these resources only for development of an application that uses the TI products described in the resource. Other reproduction and display of these resources is prohibited. No license is granted to any other TI intellectual property right or to any third party intellectual property right. TI disclaims responsibility for, and you will fully indemnify TI and its representatives against, any claims, damages, costs, losses, and liabilities arising out of your use of these resources.

TI's products are provided subject to [TI's Terms of Sale](#) or other applicable terms available either on [ti.com](https://www.ti.com) or provided in conjunction with such TI products. TI's provision of these resources does not expand or otherwise alter TI's applicable warranties or warranty disclaimers for TI products.

TI objects to and rejects any additional or different terms you may have proposed.

Mailing Address: Texas Instruments, Post Office Box 655303, Dallas, Texas 75265
Copyright © 2024, Texas Instruments Incorporated