

# TXS0102V 2-Bit Bi-Directional, Level-Shifting, Voltage Translator for Open-Drain and Push-Pull Applications

## 1 Features

- No direction-control signal needed
- Maximum data rates:
  - 24 Mbps (push pull)
  - 2 Mbps (open drain)
- Available in the Texas Instruments NanoStar™ integrated circuit package
- 1.65V to 3.6V on A port and 2.3V to 5.5V on B port ( $V_{CCA} \leq V_{CCB}$ )
- $V_{CC}$  isolation feature: if either  $V_{CC}$  input is at GND, both ports are in the High-Impedance state
- No power-supply sequencing required: either  $V_{CCA}$  or  $V_{CCB}$  can be ramped first
- $I_{off}$  supports partial-power-down mode operation
- Latch-up performance exceeds 100mA per JESD 78, Class II
- ESD protection exceeds JESD 22:
  - A port:
    - 2000V Human-Body Model (A114-B)
    - 500V Charged-Device Model (C101)
  - B port:
    - 5000V Human-Body Model (A114-B)
    - 500V Charged-Device Model (C101)

## 2 Applications

- I<sup>2</sup>C / SMBus
- UART
- GPIO

## 3 Description

This two-bit non-inverting translator is a bidirectional voltage-level translator and can be used to establish digital switching compatibility between mixed-voltage systems. It uses two separate configurable power-supply rails, with the A ports supporting operating voltages from 1.65V to 3.6V while it tracks the  $V_{CCA}$  supply, and the B ports supporting operating voltages from 2.3V to 5.5V while it tracks the  $V_{CCB}$  supply. This allows the support of both lower and higher logic signal levels while providing bidirectional translation capabilities between any of the 1.8V, 2.5V, 3.3V, and 5V voltage nodes.

When the output-enable (OE) input is low, all I/Os are placed in the high-impedance state, which significantly reduces the power-supply quiescent current consumption.

To put the device in the high-impedance state during power up or power down, OE should be tied to GND through a pulldown resistor; the current-sourcing capability of the driver determines the minimum value of the resistor.

### Package Information

PART NUMBER	PACKAGE <sup>(1)</sup>	PACKAGE SIZE <sup>(2)</sup>
TXS0102V	DCU (VSSOP, 8)	2mm × 3.1mm
	DCT (SSOP, 8)	2.95mm × 4mm

(1) For more information, see [Section 11](#).

(2) The package size (length × width) is a nominal value and includes pins, where applicable.

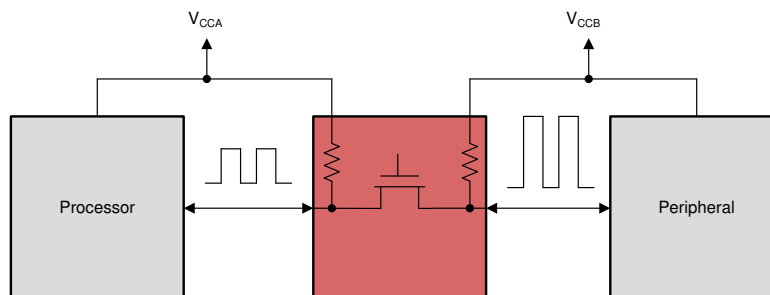

Typical Application Block Diagram for TXS0102V



## Table of Contents

<b>1 Features</b> .....	1	7.2 Functional Block Diagram.....	11
<b>2 Applications</b> .....	1	7.3 Feature Description.....	12
<b>3 Description</b> .....	1	7.4 Device Functional Modes.....	13
<b>4 Pin Configuration and Functions</b> .....	2	<b>8 Application and Implementation</b> .....	14
<b>5 Specifications</b> .....	3	8.1 Application Information.....	14
5.1 Absolute Maximum Ratings.....	3	8.2 Typical Application.....	14
5.2 ESD Ratings.....	3	8.3 Power Supply Recommendations.....	15
5.3 Recommended Operating Conditions.....	3	8.4 Layout.....	16
5.4 Thermal Information.....	4	<b>9 Device and Documentation Support</b> .....	17
5.5 Electrical Characteristics.....	4	9.1 Documentation Support.....	17
5.6 Switching Characteristics, $V_{CCA} = 1.8 \pm 0.15V$ .....	5	9.2 Receiving Notification of Documentation Updates....	17
5.7 Switching Characteristics, $V_{CCA} = 2.5 \pm 0.2V$ .....	5	9.3 Support Resources.....	17
5.8 Switching Characteristics, $V_{CCA} = 3.3 \pm 0.3V$ .....	6	9.4 Trademarks.....	17
5.9 Switching Characteristics: $T_{sk}$ , $T_{MAX}$ .....	6	9.5 Electrostatic Discharge Caution.....	17
5.10 Typical Characteristics.....	8	9.6 Glossary.....	17
<b>6 Parameter Measurement Information</b> .....	9	<b>10 Revision History</b> .....	17
<b>7 Detailed Description</b> .....	11	<b>11 Mechanical, Packaging, and Orderable Information</b> .....	17
7.1 Overview.....	11		

## 4 Pin Configuration and Functions

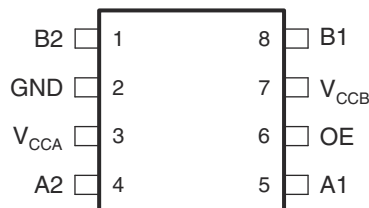

Figure 4-1. DCT or DCU Package, 8-Pin SSOP and VSSOP (Top View)

Table 4-1. Pin Functions

PIN		TYPE <sup>(1)</sup>	DESCRIPTION
NAME	NO.		
A1	5	I/O	Input/output A. Referenced to $V_{CCA}$ .
A2	4	I/O	Input/output A. Referenced to $V_{CCA}$ .
B1	8	I/O	Input/output B. Referenced to $V_{CCB}$ .
B2	1	I/O	Input/output B. Referenced to $V_{CCB}$ .
GND	2	—	Ground
OE	6	I	Output enable (active High). Pull OE low to place all outputs in 3-state mode. Referenced to $V_{CCA}$ .
$V_{CCA}$	3	P	A-port supply voltage. $1.65V \leq V_{CCA} \leq 3.6V$ and $V_{CCA} \leq V_{CCB}$
$V_{CCB}$	7	P	B-port supply voltage. $2.3V \leq V_{CCB} \leq 5.5V$

(1) I = input, O = output, I/O = input and output, P = power

## 5 Specifications

### 5.1 Absolute Maximum Ratings

over operating free-air temperature range (unless otherwise noted)<sup>(1)</sup>

			MIN	MAX	UNIT	
V <sub>CCA</sub>	Supply voltage A		-0.5	4.6	V	
V <sub>CCB</sub>	Supply voltage B		-0.5	6.5	V	
V <sub>I</sub>	Input Voltage <sup>(2)</sup>	I/O Ports (A Port)	-0.5	4.6	V	
		I/O Ports (B Port)	-0.5	6.5		
V <sub>O</sub>	Voltage applied to any output in the high-impedance or power-off state <sup>(2)</sup>	A Port	-0.5	4.6	V	
		B Port	-0.5	6.5		
V <sub>O</sub>	Voltage applied to any output in the high or low state <sup>(2) (3)</sup>	A Port	-0.5	V <sub>CCA</sub> + 0.5	V	
		B Port	-0.5	V <sub>CCB</sub> + 0.5		
I <sub>IK</sub>	Input clamp current	V <sub>I</sub> < 0		-50	mA	
I <sub>OK</sub>	Output clamp current	V <sub>O</sub> < 0		-50	mA	
I <sub>O</sub>	Continuous output current			±50	mA	
	Continuous current through V <sub>CC</sub> or GND			±100	mA	
T <sub>J</sub>	Junction Temperature			150	°C	
T <sub>stg</sub>	Storage temperature			-65	150	°C

- (1) Operation outside the *Absolute Maximum Rating* may cause permanent device damage. *Absolute Maximum Rating* do not imply functional operation of the device at these or any other conditions beyond those listed under *Recommended Operating Condition*. If used outside the *Recommended Operating Condition* but within the *Absolute Maximum Rating*, the device may not be fully functional, and this may affect device reliability, functionality, performance, and shorten the device lifetime.
- (2) The input voltage and output negative-voltage ratings may be exceeded if the input and output current ratings are observed.
- (3) The output positive-voltage rating may be exceeded up to 6.5V maximum if the output current rating is observed.

### 5.2 ESD Ratings

			VALUE	UNIT	
V <sub>(ESD)</sub>	Electrostatic discharge	Human body model (HBM), per ANSI/ESDA/JEDEC JS-001 <sup>(1)</sup>	A Port	±2000	V
			B Port	±5000	
		Charged device model (CDM), per ANSI/ESDA/JEDEC JS-002 <sup>(2)</sup>	A Port	±500	
			B Port	±500	

- (1) JEDEC document JEP155 states that 500-V HBM allows safe manufacturing with a standard ESD control process.
- (2) JEDEC document JEP157 states that 250-V CDM allows safe manufacturing with a standard ESD control process.

### 5.3 Recommended Operating Conditions

over operating free-air temperature range (unless otherwise noted) <sup>(1) (2) (3)</sup>

		V <sub>CCA</sub>	V <sub>CCB</sub>	MIN	MAX	UNIT	
V <sub>CCA</sub>	Supply voltage A			1.65	3.6	V	
V <sub>CCB</sub>	Supply voltage B			2.3	5.5	V	
V <sub>IH</sub>	High-level input voltage	A-port I/O's	1.65V to 1.95V	2.3V to 5.5V	V <sub>CCI</sub> - 0.2	V <sub>CCI</sub>	V
			1.65V to 3.6V		V <sub>CCI</sub> - 0.4	V <sub>CCI</sub>	
		B-port I/O's	1.65V to 3.6V	2.3V to 5.5V	V <sub>CCI</sub> - 0.4	V <sub>CCI</sub>	
			OE Input		1.65V to 3.6V	V <sub>CCA</sub> × 0.65	
V <sub>IL</sub>	Low-level input voltage	A-port I/O's	1.65V to 3.6V		0.15	V	
		B-port I/O's	1.65V to 3.6V	2.3V to 5.5V	0.15		
		OE Input	1.65V to 3.6V		V <sub>CCA</sub> × 0.35		
Δt/Δv	Input transition rise and fall time	Push-Pull Driving	1.65V to 3.6V	2.3V to 5.5V	10	ns/V	
T <sub>A</sub>	Operating free-air temperature				-40	85	°C

- (1) V<sub>CCI</sub> is the V<sub>CC</sub> associated with the input port.
- (2) V<sub>CCO</sub> is the V<sub>CC</sub> associated with the output port.

- (3) All control inputs and data I/Os of this device have weak pulldowns to ensure the line is not floating when undefined external to the device. The input leakage from these weak pulldowns is defined by the  $I_I$  specification indicated under [Electrical Characteristics](#).

## 5.4 Thermal Information

THERMAL METRIC <sup>(1)</sup>		TXS0102V		UNIT
		DCU	DCT	
		8 PINS	8 PINS	
$R_{\theta JA}$	Junction-to-ambient thermal resistance	239.8	168.5	°C/W
$R_{\theta JC(top)}$	Junction-to-case (top) thermal resistance	88.5	84.6	°C/W
$R_{\theta JB}$	Junction-to-board thermal resistance	151.6	96.1	°C/W
$Y_{JT}$	Junction-to-top characterization parameter	30.9	15.1	°C/W
$Y_{JB}$	Junction-to-board characterization parameter	150.5	94.7	°C/W
$R_{\theta JC(bottom)}$	Junction-to-case (bottom) thermal resistance	N/A	N/A	°C/W

- (1) For more information about traditional and new thermal metrics, see the [Semiconductor and IC Package Thermal Metrics](#) application report.

## 5.5 Electrical Characteristics

over operating free-air temperature range (unless otherwise noted)<sup>(1) (2)</sup>

PARAMETER		TEST CONDITIONS	$V_{CCA}$	$V_{CCB}$	Operating free-air temperature ( $T_A$ )						UNIT
					25°C			-40°C to 85°C			
					MIN	TYP	MAX	MIN	TYP	MAX	
$V_{OHA}$	Port A output high voltage <sup>(3)</sup>	$I_{OH} = -20 \mu A$	1.65V to 3.6V	2.3V to 5.5V	0.67 $\times V_{CCA}$			0.67 $\times V_{CCA}$			V
$V_{OLA}$	Port A output low voltage <sup>(4)</sup>	$I_{OL} = 1 \text{ mA}$	1.65V to 3.6V	2.3V to 5.5V	0.4			0.4			V
$V_{OHB}$	Port B output high voltage	$I_{OH} = -20 \mu A$	1.65V to 3.6V	2.3V to 5.5V	0.67 $\times V_{CCB}$			0.67 $\times V_{CCB}$			V
$V_{OLB}$	Port B output low voltage <sup>(4)</sup>	$I_{OL} = 1 \text{ mA}$	1.65V to 3.6V	2.3V to 5.5V	0.4			0.4			V
$I_I$	Input leakage current	OE $V_I = V_{CC}$ or GND	1.65V to 3.6V	2.3V to 5.5V	1			2			$\mu A$
$I_{off}$	Partial power down current	A port	0V	0V to 5.5V	1			2			$\mu A$
		B port	0V to 3.6V	0V	1			2			$\mu A$
$I_{OZ}$	Tri-state output current	A or B Port: $V_I = V_{CCI}$ or GND $V_O = V_{CCO}$ or GND OE = GND	1.65V to 3.6V	2.3V to 5.5V	-2			2			$\mu A$
$I_{CCA}$	$V_{CCA}$ supply current	$V_I = V_{CCI}$ or GND $I_O = 0$	1.65V to $V_{CCB}$	2.3V to 5.5V	3			3			$\mu A$
			0V	5.5V	-3			-3			
			3.6V	0V	2.2			2.2			
$I_{CCB}$	$V_{CCB}$ supply current	$V_I = V_{CCI}$ or GND $I_O = 0$	1.65V to $V_{CCB}$	2.3V to 5.5V	12			12			$\mu A$
			0V	5.5V	5			5			
			3.6V	0V	-1			-1			
$I_{CCA} + I_{CCB}$	Combined supply current	$V_I = V_{CCI}$ or GND $I_O = 0$	1.65V to $V_{CCB}$	2.3V to 5.5V	14.4			14.4			$\mu A$
$C_i$	Input Capacitance	OE	3.3V	3.3V	2.5			3.5			pF
$C_{io}$	A or B port	OE = GND, $V_O = 1.65V$ DC +1MHz -16 dBm sine wave	3.3V	3.3V	10			6			pF
	A port		5			7.5					
	B port		6			7.5					

- (1)  $V_{CCI}$  is the  $V_{CC}$  associated with the input port  
(2)  $V_{CCO}$  is the  $V_{CC}$  associated with the output port  
(3) Tested at  $V_I = V_{T+(MAX)}$   
(4) Tested at  $V_I = V_{T-(MIN)}$

### 5.6 Switching Characteristics, $V_{CCA} = 1.8 \pm 0.15V$

PARAMETER		FROM	TO	Test Conditions	B-Port Supply Voltage ( $V_{CCB}$ )						UNIT			
					2.5 ± 0.2V			3.3 ± 0.3V				5.0 ± 0.5V		
					MIN	TYP	MAX	MIN	TYP	MAX		MIN	TYP	MAX
$t_{PHL}$	Propagation Delay (High-to-Low)	A	B	Push-Pull	5			5			6			ns
				Open-Drain	8.8			9.6			10			
$t_{PLH}$	Propagation Delay (Low-to-High)	A	B	Push-Pull	6.5			7			7			ns
				Open-Drain	250			200			185			
$t_{PHL}$	Propagation Delay (High-to-Low)	B	A	Push-Pull	4			4			5			ns
					5.3			4.4			4			
$t_{PLH}$	Propagation Delay (Low-to-High)	B	A	Push-Pull	5			4			1			ns
					173			89			66			
$t_{en}$	Enable Time	OE	A or B	-40°C to 85°C	200			200			200			ns
	Disable Time				250			250			250			
$t_{rA}$	Output Rise Time	B	A	Push-Pull	9			9			7			ns
				Open-Drain	150			120			80			
$t_{rB}$	Output Rise Time	A	B	Push-Pull	10			9			7			ns
				Open-Drain	145			106			58			
$t_{fA}$	Output Fall Time	B	A	Push-Pull	5			6			13			ns
				Open-Drain	6			6			6			
$t_{fB}$	Output Fall Time	A	B	Push-Pull	7			7			8			ns
				Open-Drain	13			16			16			

### 5.7 Switching Characteristics, $V_{CCA} = 2.5 \pm 0.2V$

PARAMETER		FROM	TO	Test Conditions	B-Port Supply Voltage ( $V_{CCB}$ )						UNIT			
					2.5 ± 0.2V			3.3 ± 0.3V				5.0 ± 0.5V		
					MIN	TYP	MAX	MIN	TYP	MAX		MIN	TYP	MAX
$t_{PHL}$	Propagation Delay (High-to-Low)	A	B	Push-Pull	3.2			3.7			5			ns
				Open-Drain	6.3			6			5.8			
$t_{PLH}$	Propagation Delay (Low-to-High)	A	B	Push-Pull	3			4			4			ns
				Open-Drain	200			200			190			
$t_{PHL}$	Propagation Delay (High-to-Low)	B	A	Push-Pull	3			3			4			ns
				Open-Drain	4.7			4.2			4			
$t_{PLH}$	Propagation Delay (Low-to-High)	B	A	Push-Pull	2.1			1.6			1			ns
				Open-Drain	170			140			103			
$t_{en}$	Enable Time	OE	A or B	-40°C to 85°C	200			200			200			ns
$t_{dis}$	Disable Time				250			250			250			
$t_{rA}$	Output Rise Time	B	A	Push-Pull	7			6			5			ns
				Open-Drain	156			120			80			
$t_{rB}$	Output Rise Time	A	B	Push-Pull	8			7			6			ns
				Open-Drain	151			112			64			
$t_{fA}$	Output Fall Time	B	A	Push-Pull	5.1			5.2			5			ns
				Open-Drain	6			6			5			
$t_{fB}$	Output Fall Time	A	B	Push-Pull	7			6.4			8.7			ns
				Open-Drain	8			9			10			

### 5.8 Switching Characteristics, $V_{CCA} = 3.3 \pm 0.3V$

PARAMETER	FROM	TO	Test Conditions	B-Port Supply Voltage ( $V_{CCB}$ )						UNIT	
				3.3 ± 0.3V			5.0 ± 0.5V				
				MIN	TYP	MAX	MIN	TYP	MAX		
$t_{PHL}$	Propagation Delay (High-to-Low)	A	B	Push-Pull	2.4			3.1			ns
				Open-Drain	4.2			4.6			
$t_{PLH}$	Propagation Delay (Low-to-High)	A	B	Push-Pull	4			4			ns
				Open-Drain	204			165			
$t_{PHL}$	Propagation Delay (High-to-Low)	B	A	Push-Pull	2.5			3.3			ns
				Open-Drain	124			97			
$t_{PLH}$	Propagation Delay (Low-to-High)	B	A	Push-Pull	2.5			2.6			ns
				Open-Drain	139			105			
$t_{en}$	Enable Time	OE	A or B	-40°C to 85°C	200			200			ns
	Disable Time	OE	A or B		250			250			
$t_{rA}$	Output Rise Time	B	A	Push-Pull	5			4			ns
				Open-Drain	116			85			
$t_{rB}$	Output Rise Time	A	B	Push-Pull	6			7			ns
				Open-Drain	117			116			
$t_{fA}$	Output Fall Time	B	A	Push-Pull	5.4			5			ns
				Open-Drain	6			5			
$t_{fB}$	Output Fall Time	A	B	Push-Pull	7.4			7.6			ns
				Open-Drain	7			8			

### 5.9 Switching Characteristics: $T_{sk}$ , $T_{MAX}$

over operating free-air temperature range (unless otherwise noted)

PARAMETER	TEST CONDITIONS	$V_{CCA}$	$V_{CCB}$	Operating free-air temperature ( $T_A$ )			UNIT
				-40°C to 85°C			
				MIN	TYP	MAX	
$T_{MAX}$ - Maximum Data Rate	50% Duty Cycle Input One channel switching	Push-Pull Driving	1.8 ± 0.15V	2.5V ± 0.2V	18		Mbps
				3.3V ± 0.3V	21		
				5V ± 0.5V	23		
$T_{MAX}$ - Maximum Data Rate	50% Duty Cycle Input One channel switching	Push-Pull Driving	2.5V ± 0.2V	2.5V ± 0.2V	20		Mbps
$T_{MAX}$ - Maximum Data Rate	50% Duty Cycle Input One channel switching	Push-Pull Driving	2.5V ± 0.2V	3.3V ± 0.3V	22		
$T_{MAX}$ - Maximum Data Rate	50% Duty Cycle Input One channel switching	Push-Pull Driving	2.5V ± 0.2V	5V ± 0.5V	24		
$T_{MAX}$ - Maximum Data Rate	50% Duty Cycle Input One channel switching	Push-Pull Driving	3.3V ± 0.3V	3.3V ± 0.3V	22		
$T_{MAX}$ - Maximum Data Rate	50% Duty Cycle Input One channel switching	Open-Drain Driving	1.8 ± 0.15V	2.5V ± 0.2V	2		Mbps
				3.3V ± 0.3V	2		
				5V ± 0.5V	2		
$T_{MAX}$ - Maximum Data Rate	50% Duty Cycle Input One channel switching	Open-Drain Driving	2.5V ± 0.2V	2.5V ± 0.2V	2		Mbps
				3.3V ± 0.3V	2		
				5V ± 0.5V	2		
$T_{MAX}$ - Maximum Data Rate	50% Duty Cycle Input One channel switching	Open-Drain Driving	3.3V ± 0.3V	3.3V ± 0.3V	2		Mbps
				5V ± 0.5V	2		
				5V ± 0.5V	2		
$t_w$	Pulse Duration, Data Inputs	Push-Pull Driving	1.8V ± 0.15V to 3.3V ± 0.3V	2.5V ± 0.2V 5.0V ± 0.5V	41		ns

## 5.9 Switching Characteristics: $T_{sk}$ , $T_{MAX}$ (continued)

over operating free-air temperature range (unless otherwise noted)

PARAMETER	TEST CONDITIONS		$V_{CCA}$	$V_{CCB}$	Operating free-air temperature ( $T_A$ )			UNIT
					-40°C to 85°C			
					MIN	TYP	MAX	
$t_w$	Pulse Duration, Data Inputs	Open-Drain Driving	1.8V ± 0.15V to 3.3V ± 0.3V	2.5V ± 0.2V 5.0V ± 0.5V	500			ns
$t_{sk}$ - Output skew	Skew between any two outputs of the same package switching in the same direction	Push-Pull Driving	1.8V ± 0.15V to 3.3V ± 0.3V	2.5V ± 0.2V 5.0V ± 0.5V	1			ns
$t_{sk}$ - Output skew	Skew between any two outputs of the same package switching in the same direction	Open-Drain Driving	1.8V ± 0.15V to 3.3V ± 0.3V	2.5V ± 0.2V 5.0V ± 0.5V	1			ns

## 5.10 Typical Characteristics

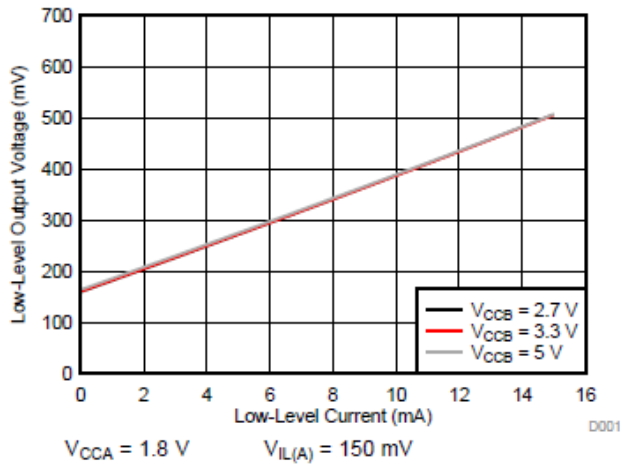

Figure 5-1. Low-Level Output Voltage ( $V_{OL(Bx)}$ ) vs Low-Level Current ( $I_{OL(Bx)}$ )

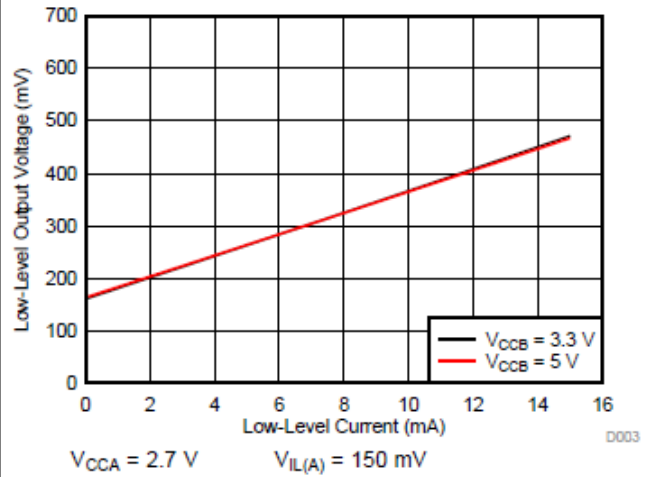

Figure 5-2. Low-Level Output Voltage ( $V_{OL(Bx)}$ ) vs Low-Level Current ( $I_{OL(Bx)}$ )

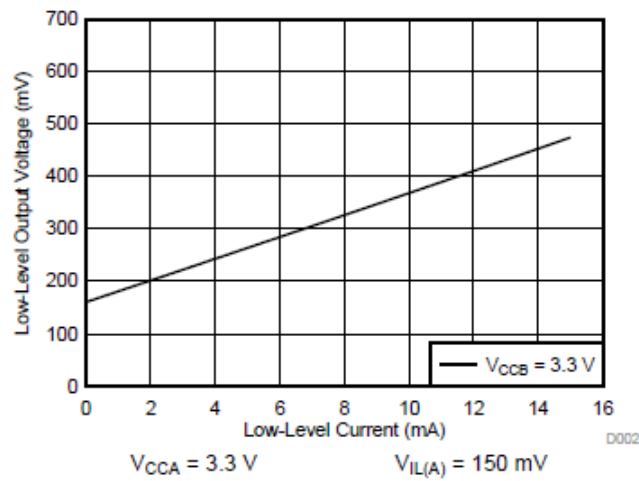

Figure 5-3. Low-Level Output Voltage ( $V_{OL(Bx)}$ ) vs Low-Level Current ( $I_{OL(Bx)}$ )

## 6 Parameter Measurement Information

Unless otherwise noted, all input pulses are supplied by generators having the following characteristics:

- PRR 10MHz
- $Z_O = 50 \Omega$
- $dv/dt \geq 1V/ns$

### Note

All parameters and waveforms are not applicable to all devices.

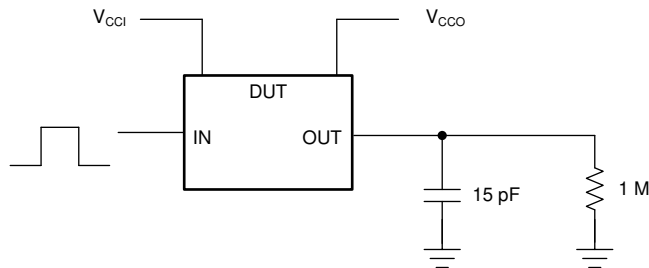

**Figure 6-1. Data Rate, Pulse Duration, Propagation Delay, Output Rise And Fall Time Measurement Using A Push-Pull Driver**

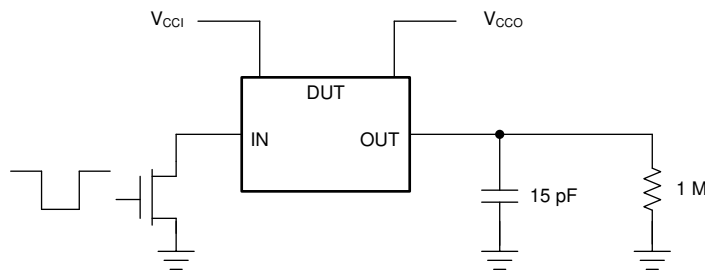

**Figure 6-2. Data Rate, Pulse Duration, Propagation Delay, Output Rise And Fall Time Measurement Using An Open-Drain Driver**

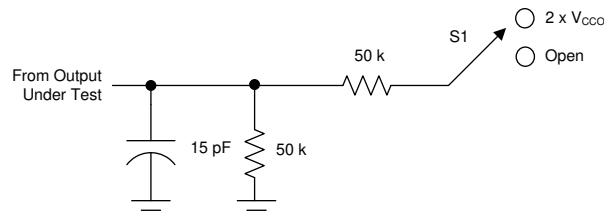

**Figure 6-3. Load Circuit For Enable / Disable Time Measurement**

**Table 6-1. Switch Configuration For Enable / Disable Timing**

TEST	S1
$t_{PZL}^{(2)}$ , $t_{PLZ}^{(1)}$	$2 \times V_{CCO}$
$t_{PHZ}^{(1)}$ , $t_{PZH}^{(2)}$	Open

(1)  $t_{PLZ}$  and  $t_{PHZ}$  are the same as  $t_{dis}$ .

(2)  $t_{PZL}$  and  $t_{PZH}$  are the same as  $t_{en}$ .

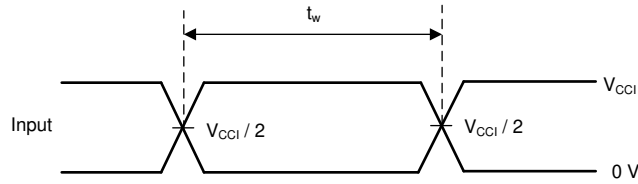

(1) All input pulses are measured one at a time, with one transition per measurement.

**Figure 6-4. Voltage Waveforms Pulse Duration**

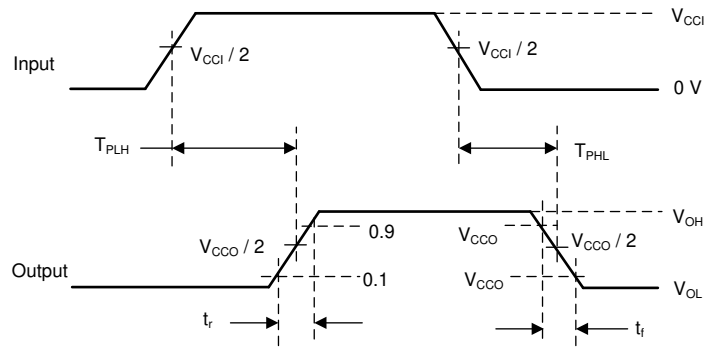

(1) All input pulses are measured one at a time, with one transition per measurement.

**Figure 6-5. Voltage Waveforms Propagation Delay Times**

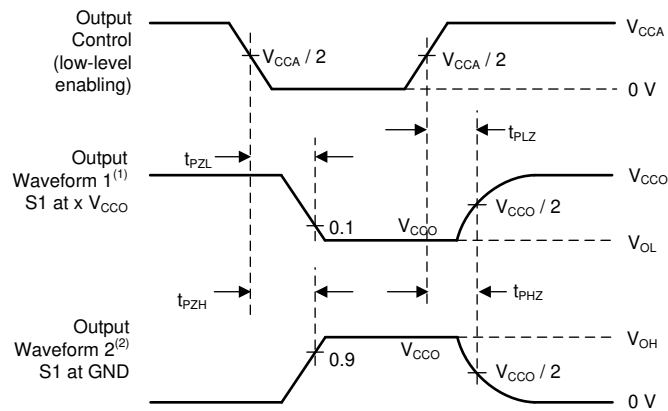

(1) Waveform 1 is for an output with internal conditions so that the output is low, except when disabled by the output control.  
 (2) Waveform 2 is for an output with internal conditions so that the output is high, except when disabled by the output control.

**Figure 6-6. Voltage Waveforms Enable And Disable Times**

## 7 Detailed Description

### 7.1 Overview

The TXS0102V device is a directionless voltage-level translator specifically designed for translating logic voltage levels. The A port can accept I/O voltages ranging from 1.65V to 3.6V, while the B port can accept I/O voltages from 2.3V to 5.5V. The device is a pass-gate architecture with edge-rate accelerators (one-shots) to improve the overall data rate. 10kΩ pullup resistors, commonly used in open-drain applications, have been conveniently integrated so that an external resistor is not needed. While this device is designed for open-drain applications, the device can also translate push-pull CMOS logic outputs.

### 7.2 Functional Block Diagram

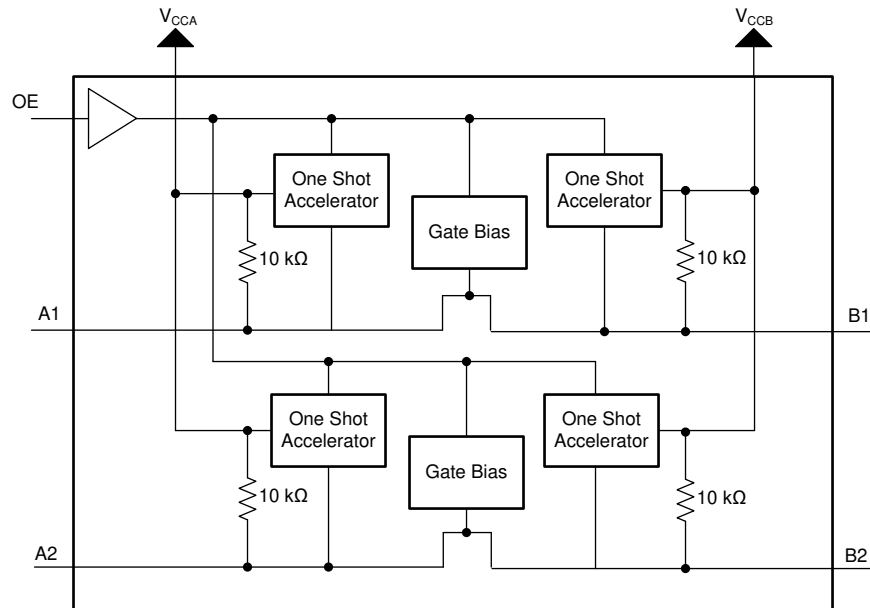

## 7.3 Feature Description

### 7.3.1 Architecture

The TXS0102V architecture (see [Figure 7-1](#)) is an auto-direction-sensing based translator that does not require a direction-control signal to control the direction of data flow from A to B or from B to A.

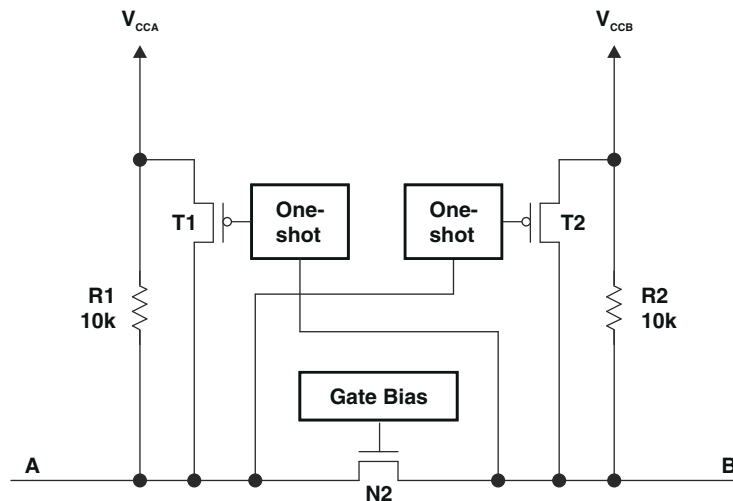

Figure 7-1. Architecture of a TXS0102V Cell

These two bidirectional channels independently determine the direction of data flow without a direction-control signal. Each I/O pin can be automatically reconfigured as either an input or an output, which is how this auto-direction feature is realized.

The TXS0102V device is part of TI's "Switch" type voltage translator family and employs two key circuits to enable this voltage translation:

1. An N-channel pass-gate transistor topology that ties the A-port to the B-port
2. Output one-shot (O.S.) edge-rate accelerator circuitry to detect and accelerate rising edges on the A or B ports

For bidirectional voltage translation, pull-up resistors are included on the device for dc current sourcing capability. The  $V_{GATE}$  gate bias of the N-channel pass transistor is set at approximately one threshold voltage ( $V_T$ ) above the  $V_{CC}$  level of the low-voltage side. Data can flow in either direction without guidance from a control signal.

The O.S. rising-edge rate accelerator circuitry speeds up the output slew rate by monitoring the input edge for transitions, helping maintain the data rate through the device. During a low-to-high signal rising edge, the O.S. circuits turn on the PMOS transistors (T1 and T2) to increase the current drive capability of the driver for approximately 30ns or 95% of the input edge, whichever occurs first. This edge-rate acceleration provides high ac drive by bypassing the internal 10k $\Omega$  pull-up resistors during the low-to-high transition to speed up the signal. The output resistance of the driver is decreased to approximately 50 $\Omega$  to 70 $\Omega$  during this acceleration phase. To minimize dynamic  $I_{CC}$  and the possibility of signal contention, the user should wait for the O.S. circuit to turn off before applying a signal in the opposite direction. The worst-case duration is equal to the minimum pulse-width number provided in the [Switching Characteristics](#) section of this data sheet.

### 7.3.2 Input Driver Requirements

the external system-level open-drain (or push-pull) drivers that are interfaced to the TXS0102V I/O pins determines the continuous dc-current *sinking* capability. Since the high bandwidth of these bidirectional I/O circuits is used to facilitate this fast change from an input to an output and an output to an input, they have a modest dc-current *sourcing* capability of hundreds of micro-Amps, as determined by the internal 10k $\Omega$  pullup resistors.

The fall time ( $t_{fA}$ ,  $t_{fB}$ ) of a signal depends on the edge-rate and output impedance of the external device driving TXS0102V data I/Os, as well as the capacitive loading on the data lines.

Similarly, the  $t_{PHL}$  and max data rates also depend on the output impedance of the external driver. The values for  $t_{fA}$ ,  $t_{fB}$ ,  $t_{PHL}$ , and maximum data rates in the data sheet assume that the output impedance of the external driver is less than 50 $\Omega$ .

### 7.3.3 Output Load Considerations

TI recommends careful PCB layout practices with short PCB trace lengths to avoid excessive capacitive loading and to determine that proper O.S. triggering takes place. PCB signal trace-lengths should be kept short enough so that the round trip delay of any reflection is less than the one-shot duration. This improves signal integrity by allowing any reflection sees a low impedance at the driver. The O.S. circuits are designed to stay on for approximately 30ns.

The maximum capacitance of the lumped load that can be driven also depends directly on the one-shot duration. With very heavy capacitive loads, the one-shot can time-out before the signal is driven fully to the positive rail. The O.S. duration has been set to best optimize trade-offs between dynamic ICC, load driving capability, and maximum bit-rate considerations. Both PCB trace length and connectors add to the capacitance that the TXS0102V device output sees, so it is recommended that this lumped-load capacitance be considered to avoid O.S. retriggering, bus contention, output signal oscillations, or other adverse system-level affects.

### 7.3.4 Enable and Disable

The TXS0102V device has an OE input that is used to disable the device by setting OE low, which places all I/Os in the Hi-Z state. The disable time ( $t_{dis}$ ) indicates the delay between the time when OE goes low and when the outputs are disabled (Hi-Z). The enable time ( $t_{en}$ ) indicates the amount of time the user must allow for the one-shot circuitry to become operational after OE is taken high.

### 7.3.5 Pullup or Pulldown Resistors on I/O Lines

Each A-port I/O has an internal 10k $\Omega$  pullup resistor to  $V_{CCA}$ , and each B-port I/O has an internal 10k $\Omega$  pullup resistor to  $V_{CCB}$ . If a smaller value of pullup resistor is required, an external resistor must be added from the I/O to  $V_{CCA}$  or  $V_{CCB}$  (in parallel with the internal 10k $\Omega$  resistors). Adding lower value pull-up resistors will effect  $V_{OL}$  levels, however. The internal pull-ups of the TXS0102V are disabled when the OE pin is low.

## 7.4 Device Functional Modes

The device has two functional modes, enabled and disabled. To disable the device set the OE input low, which places all I/Os in a high impedance state. Setting the OE input high will enable the device.

## 8 Application and Implementation

### Note

Information in the following applications sections is not part of the TI component specification, and TI does not warrant its accuracy or completeness. TI's customers are responsible for determining suitability of components for their purposes, as well as validating and testing their design implementation to confirm system functionality.

### 8.1 Application Information

The TXS0102V device can be used to bridge the digital-switching compatibility gap between two voltage nodes to successfully interface logic threshold levels found in electronic systems. It should be used in a point-to-point topology for interfacing devices or systems operating at different interface voltages with one another. Its primary target application use is for interfacing with open-drain drivers on the data I/Os such as I<sup>2</sup>C or 1-wire, where the data is bidirectional and no control signal is available. The device can also be used in applications where a push-pull driver is connected to the data I/Os, but the TXB0102 might be a better option for such push-pull applications.

### 8.2 Typical Application

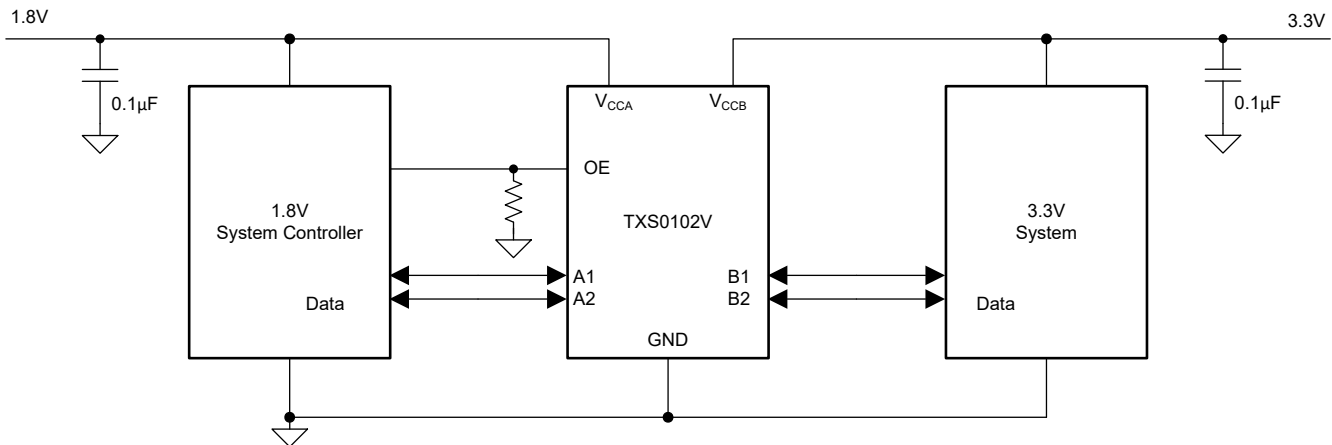

Figure 8-1. Typical Application Circuit

#### 8.2.1 Design Requirements

Use the parameters listed in [Table 8-1](#) for this design example, and ensure the  $V_{CCA} \leq V_{CCB}$ .

Table 8-1. Design Parameters

DESIGN PARAMETER	EXAMPLE VALUE
Input voltage range	1.65 to 3.6V
Output voltage range	2.3 to 5.5V

### 8.2.2 Detailed Design Procedure

To begin the design process, determine the following:

- Input voltage range
  - Use the supply voltage of the device that is driving the TXS0102V device to determine the input voltage range. For a valid logic high the value must exceed the  $V_{IH}$  of the input port. For a valid logic low the value must be less than the  $V_{IL}$  of the input port.
- Output voltage range
  - Use the supply voltage of the device that the TXS0102V device is driving to determine the output voltage range.
  - The TXS0102V device has 10k $\Omega$  internal pullup resistors. External pullup resistors can be added to reduce the total RC of a signal trace if necessary.
- An external pull down resistor decreases the output  $V_{OH}$  and  $V_{OL}$ . Use [Equation 1](#) to calculate the  $V_{OH}$  as a result of an external pull down resistor.

$$V_{OH} = V_{CCx} \times R_{PD} / (R_{PD} + 10k\Omega) \quad (1)$$

- Where:
- $V_{CCx}$  is the supply voltage on either  $V_{CCA}$  or  $V_{CCB}$
- $R_{PD}$  is the value of the external pull down resistor

### 8.2.3 Application Curves

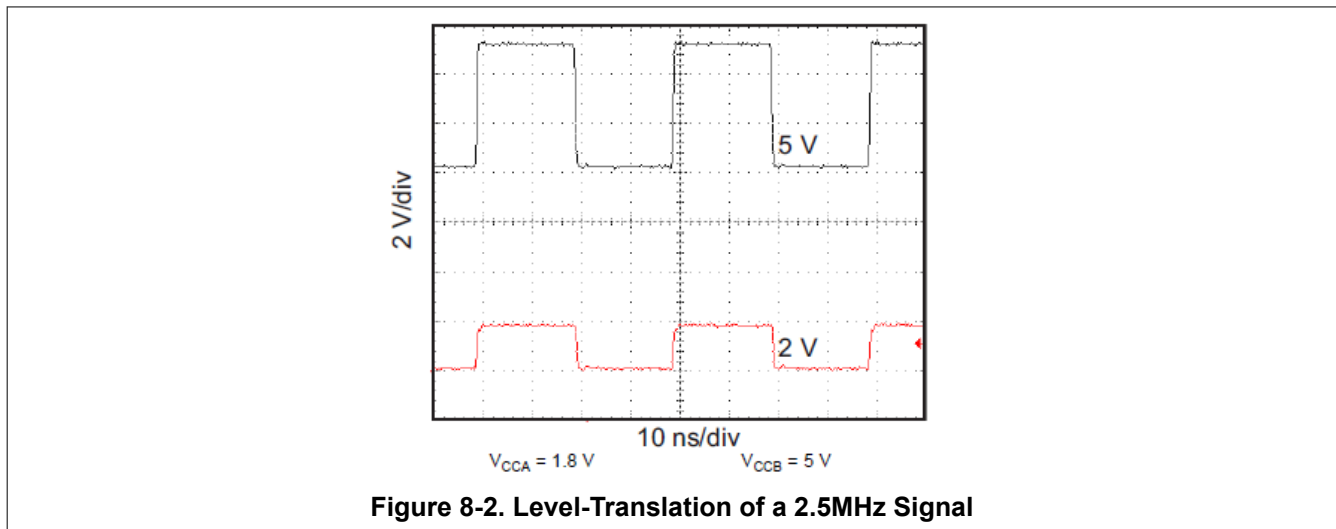

### 8.3 Power Supply Recommendations

During operation, ensure that  $V_{CCA} \leq V_{CCB}$  at all times. The sequencing of each power supply will not damage the device during the power up operation, so either power supply can be ramped up first. The output-enable (OE) input circuit is designed so that it is supplied by  $V_{CCA}$  and when the (OE) input is low, all outputs are placed in the high-impedance state.

To put the outputs in the high-impedance state during power up or power down, the OE input pin must be tied to GND through a pulldown resistor and must not be enabled until  $V_{CCA}$  and  $V_{CCB}$  are fully ramped and stable. The current-sourcing capability of the driver determines the minimum value of the pulldown resistor to ground.

## 8.4 Layout

### 8.4.1 Layout Guidelines

For device reliability, it is recommended to follow common printed-circuit board layout guidelines such as follows:

- Bypass capacitors should be used on power supplies and should be placed as close as possible to the  $V_{CCA}$ ,  $V_{CCB}$  pin, and  $G_{ND}$  pin.
- Short trace lengths should be used to avoid excessive loading.
- PCB signal trace-lengths must be kept short enough so that the round-trip delay of any reflection is less than the one-shot duration, approximately 30ns, causing any reflection encounters low impedance at the source driver.

### 8.4.2 Layout Example

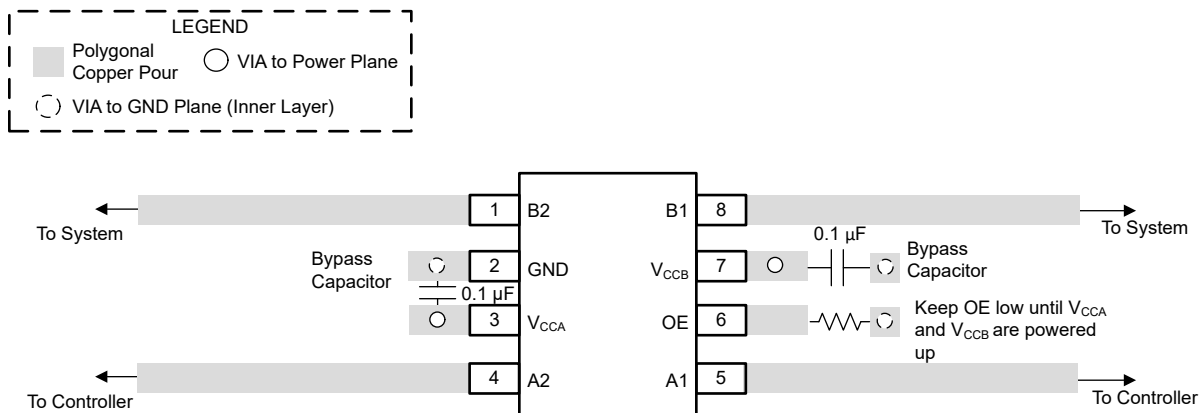

## 9 Device and Documentation Support

### 9.1 Documentation Support

#### 9.1.1 Related Documentation

For related documentation see the following:

- Texas Instruments, [A Guide to Voltage Translation With TXS-Type Translators application note](#)
- Texas Instruments, [Factors Affecting VOL for TXS and LSF Auto-bidirectional Translation Devices application note](#)
- Texas Instruments, [Biasing Requirements for TXS, TXB, and LSF Auto-Bidirectional Translators application note](#)
- Texas Instruments, [Effects of pullup and pulldown resistors on TXS and TXB devices application note](#)
- Texas Instruments, [Introduction to logic application note](#)
- Texas Instruments, [TI Logic and Linear Products Guide selection and solution guides](#)
- Texas Instruments, [Washing Machine Solutions Guide selection and solution guides](#)
- Texas Instruments, [TI Smartphone Solutions Guide selection and solution guides](#)

### 9.2 Receiving Notification of Documentation Updates

To receive notification of documentation updates, navigate to the device product folder on [ti.com](https://www.ti.com). Click on *Subscribe to updates* to register and receive a weekly digest of any product information that has changed. For change details, review the revision history included in any revised document.

### 9.3 Support Resources

[TI E2E™ support forums](#) are an engineer's go-to source for fast, verified answers and design help — straight from the experts. Search existing answers or ask your own question to get the quick design help you need.

Linked content is provided "AS IS" by the respective contributors. They do not constitute TI specifications and do not necessarily reflect TI's views; see TI's [Terms of Use](#).

### 9.4 Trademarks

NanoStar™ is a trademark of Texas Instruments Incorporated.

TI E2E™ is a trademark of Texas Instruments.

All trademarks are the property of their respective owners.

### 9.5 Electrostatic Discharge Caution



This integrated circuit can be damaged by ESD. Texas Instruments recommends that all integrated circuits be handled with appropriate precautions. Failure to observe proper handling and installation procedures can cause damage.

ESD damage can range from subtle performance degradation to complete device failure. Precision integrated circuits may be more susceptible to damage because very small parametric changes could cause the device not to meet its published specifications.

### 9.6 Glossary

[TI Glossary](#) This glossary lists and explains terms, acronyms, and definitions.

## 10 Revision History

DATE	REVISION	NOTES
June 2024	*	Initial Release

## 11 Mechanical, Packaging, and Orderable Information

The following pages include mechanical, packaging, and orderable information. This information is the most current data available for the designated devices. This data is subject to change without notice and revision of this document. For browser-based versions of this data sheet, refer to the left-hand navigation.

**PACKAGING INFORMATION**

Orderable Device	Status (1)	Package Type	Package Drawing	Pins	Package Qty	Eco Plan (2)	Lead finish/ Ball material (6)	MSL Peak Temp (3)	Op Temp (°C)	Device Marking (4/5)	Samples
TXS0102VDCTR	ACTIVE	SM8	DCT	8	3000	RoHS & Green	SN	Level-1-260C-UNLIM	-40 to 85	3IFT	<a href="#">Samples</a>
TXS0102VDCUR	ACTIVE	VSSOP	DCU	8	3000	RoHS & Green	SN	Level-1-260C-UNLIM	-40 to 85		<a href="#">Samples</a>

(1) The marketing status values are defined as follows:

**ACTIVE:** Product device recommended for new designs.

**LIFEBUY:** TI has announced that the device will be discontinued, and a lifetime-buy period is in effect.

**NRND:** Not recommended for new designs. Device is in production to support existing customers, but TI does not recommend using this part in a new design.

**PREVIEW:** Device has been announced but is not in production. Samples may or may not be available.

**OBSOLETE:** TI has discontinued the production of the device.

(2) **RoHS:** TI defines "RoHS" to mean semiconductor products that are compliant with the current EU RoHS requirements for all 10 RoHS substances, including the requirement that RoHS substance do not exceed 0.1% by weight in homogeneous materials. Where designed to be soldered at high temperatures, "RoHS" products are suitable for use in specified lead-free processes. TI may reference these types of products as "Pb-Free".

**RoHS Exempt:** TI defines "RoHS Exempt" to mean products that contain lead but are compliant with EU RoHS pursuant to a specific EU RoHS exemption.

**Green:** TI defines "Green" to mean the content of Chlorine (Cl) and Bromine (Br) based flame retardants meet JS709B low halogen requirements of <=1000ppm threshold. Antimony trioxide based flame retardants must also meet the <=1000ppm threshold requirement.

(3) MSL, Peak Temp. - The Moisture Sensitivity Level rating according to the JEDEC industry standard classifications, and peak solder temperature.

(4) There may be additional marking, which relates to the logo, the lot trace code information, or the environmental category on the device.

(5) Multiple Device Markings will be inside parentheses. Only one Device Marking contained in parentheses and separated by a "~" will appear on a device. If a line is indented then it is a continuation of the previous line and the two combined represent the entire Device Marking for that device.

(6) Lead finish/Ball material - Orderable Devices may have multiple material finish options. Finish options are separated by a vertical ruled line. Lead finish/Ball material values may wrap to two lines if the finish value exceeds the maximum column width.

**Important Information and Disclaimer:**The information provided on this page represents TI's knowledge and belief as of the date that it is provided. TI bases its knowledge and belief on information provided by third parties, and makes no representation or warranty as to the accuracy of such information. Efforts are underway to better integrate information from third parties. TI has taken and continues to take reasonable steps to provide representative and accurate information but may not have conducted destructive testing or chemical analysis on incoming materials and chemicals. TI and TI suppliers consider certain information to be proprietary, and thus CAS numbers and other limited information may not be available for release.

In no event shall TI's liability arising out of such information exceed the total purchase price of the TI part(s) at issue in this document sold by TI to Customer on an annual basis.

**OTHER QUALIFIED VERSIONS OF TXS0102V :**

- Automotive : [TXS0102V-Q1](#)

## NOTE: Qualified Version Definitions:

- Automotive - Q100 devices qualified for high-reliability automotive applications targeting zero defects

## IMPORTANT NOTICE AND DISCLAIMER

TI PROVIDES TECHNICAL AND RELIABILITY DATA (INCLUDING DATA SHEETS), DESIGN RESOURCES (INCLUDING REFERENCE DESIGNS), APPLICATION OR OTHER DESIGN ADVICE, WEB TOOLS, SAFETY INFORMATION, AND OTHER RESOURCES "AS IS" AND WITH ALL FAULTS, AND DISCLAIMS ALL WARRANTIES, EXPRESS AND IMPLIED, INCLUDING WITHOUT LIMITATION ANY IMPLIED WARRANTIES OF MERCHANTABILITY, FITNESS FOR A PARTICULAR PURPOSE OR NON-INFRINGEMENT OF THIRD PARTY INTELLECTUAL PROPERTY RIGHTS.

These resources are intended for skilled developers designing with TI products. You are solely responsible for (1) selecting the appropriate TI products for your application, (2) designing, validating and testing your application, and (3) ensuring your application meets applicable standards, and any other safety, security, regulatory or other requirements.

These resources are subject to change without notice. TI grants you permission to use these resources only for development of an application that uses the TI products described in the resource. Other reproduction and display of these resources is prohibited. No license is granted to any other TI intellectual property right or to any third party intellectual property right. TI disclaims responsibility for, and you will fully indemnify TI and its representatives against, any claims, damages, costs, losses, and liabilities arising out of your use of these resources.

TI's products are provided subject to [TI's Terms of Sale](#) or other applicable terms available either on [ti.com](https://www.ti.com) or provided in conjunction with such TI products. TI's provision of these resources does not expand or otherwise alter TI's applicable warranties or warranty disclaimers for TI products.

TI objects to and rejects any additional or different terms you may have proposed.

Mailing Address: Texas Instruments, Post Office Box 655303, Dallas, Texas 75265  
Copyright © 2024, Texas Instruments Incorporated