

AMC3306M05-Q1 Automotive, Precision, $\pm 50\text{mV}$ Input, Reinforced Isolated Delta-Sigma Modulator With Integrated DC/DC Converter

1 Features

- AEC-Q100 qualified for automotive applications:
 - Temperature grade 1: -40°C to $+125^{\circ}\text{C}$, T_A
- Single-supply operation (3.3V or 5V) with integrated DC/DC converter
- Input voltage range ($\pm 50\text{mV}$) optimized for current measurement using shunt resistors
- Low DC errors:
 - Offset error: $\pm 50\mu\text{V}$ (max)
 - Offset drift: $\pm 0.4\mu\text{V}/^{\circ}\text{C}$ (max)
 - Gain error: $\pm 0.2\%$ (max)
 - Gain drift: $\pm 35\text{ppm}/^{\circ}\text{C}$ (max)
- High CMTI: $75\text{kV}/\mu\text{s}$ (min)
- System-level diagnostic features
- Low EMI: Meets CISPR-11 and CISPR-25 standards
- Safety-related certifications:
 - 6000V_{PK} reinforced isolation per DIN EN IEC 60747-17 (VDE 0884-17)
 - $4250\text{V}_{\text{RMS}}$ isolation for 1 minute per UL1577

2 Applications

- Compact, isolated shunt-based current sensing in:
 - [HEV/EV onboard chargers \(OBC\)](#)
 - [HEV/EV DC/DC converters](#)
 - [HEV/EV traction inverters](#)
 - [HEV/EV battery management system \(BMS\)](#)

3 Description

The AMC3306M05-Q1 is a precision, isolated delta-sigma ($\Delta\Sigma$) modulator, optimized for shunt-based current measurements. The fully integrated, isolated DC/DC converter allows single-supply operation from the low-side of the device which makes the device a unique solution for space-constrained applications. The reinforced capacitive isolation barrier is certified according to DIN EN IEC 60747-17 (VDE 0884-17) and UL1577 and supports a working voltage up to $1.2\text{kV}_{\text{RMS}}$.

The isolation barrier separates parts of the system that operate on different common-mode voltage levels and protects the low-voltage side from hazardous voltages and damage.

The input of the AMC3306M05-Q1 is optimized for direct connection to a low-impedance shunt resistor or other, low-impedance voltage source with low signal levels. The excellent DC accuracy and low temperature drift supports accurate current measurements over the extended industrial temperature range from -40°C to $+125^{\circ}\text{C}$.

Use a digital filter (such as a sinc^3 filter) to decimate the bitstream. By using this digital filter, the device achieves 16 bits of resolution with an 85dB dynamic range at a data rate of 78kSPS.

Package Information

PART NUMBER	PACKAGE ⁽¹⁾	PACKAGE SIZE ⁽²⁾
AMC3306M05-Q1	DWE (SOIC, 16)	10.3mm × 10.3mm

(1) For more information, see the [Mechanical, Packaging, and Orderable Information](#).

(2) The package size (length × width) is a nominal value and includes pins, where applicable.

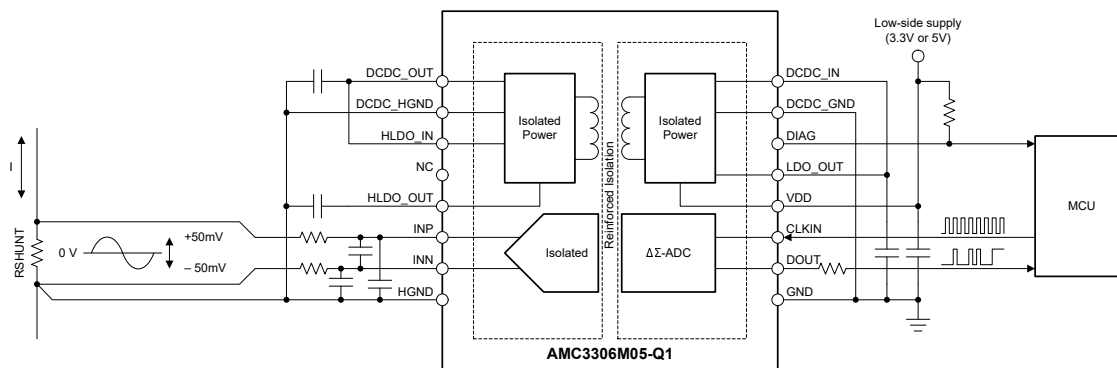

Typical Application



Table of Contents

1 Features	1	6.1 Overview.....	19
2 Applications	1	6.2 Functional Block Diagram.....	19
3 Description	1	6.3 Feature Description.....	20
4 Pin Configuration and Functions	3	6.4 Device Functional Modes.....	24
5 Specifications	4	7 Application and Implementation	25
5.1 Absolute Maximum Ratings.....	4	7.1 Application Information.....	25
5.2 ESD Ratings.....	4	7.2 Typical Application.....	26
5.3 Recommended Operating Conditions.....	4	7.3 Power Supply Recommendations.....	29
5.4 Thermal Information.....	5	7.4 Layout.....	31
5.5 Power Ratings.....	5	8 Device and Documentation Support	32
5.6 Insulation Specifications.....	6	8.1 Documentation Support.....	32
5.7 Safety-Related Certifications	7	8.2 Receiving Notification of Documentation Updates...32	
5.8 Safety Limiting Values.....	7	8.3 Support Resources.....	32
5.9 Electrical Characteristics.....	8	8.4 Trademarks.....	32
5.10 Switching Characteristics.....	10	8.5 Electrostatic Discharge Caution.....	32
5.11 Timing Diagrams.....	10	8.6 Glossary.....	32
5.12 Insulation Characteristics Curves.....	11	9 Revision History	32
5.13 Typical Characteristics.....	12	10 Mechanical, Packaging, and Orderable Information	32
6 Detailed Description	19		

4 Pin Configuration and Functions

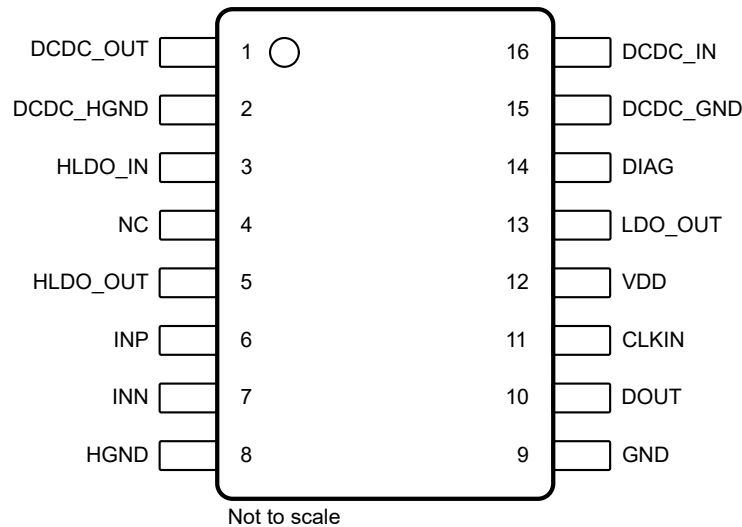

Figure 4-1. DWE Package, 16-Pin SOIC (Top View)

Table 4-1. Pin Functions

PIN		TYPE	DESCRIPTION
NO.	NAME		
1	DCDC_OUT	Power	High-side output of the DC/DC converter; connect this pin to the HLDO_IN pin. ⁽¹⁾
2	DCDC_HGND	High-side power ground	High-side ground reference for the DC/DC converter; connect this pin to the HGND pin.
3	HLDO_IN	Power	Input of the high-side LDO; connect this pin to the DCDC_OUT pin. ⁽¹⁾
4	NC	—	No internal connection. Connect this pin to the high-side ground or leave unconnected (floating).
5	HLDO_OUT	Power	Output of the high-side LDO. ⁽¹⁾
6	INP	Analog input	Noninverting analog input. Make sure INP or INN has a DC current path to HGND to define the common-mode input voltage. ⁽²⁾
7	INN	Analog input	Inverting analog input. Make sure INP or INN has a DC current path to HGND to define the common-mode input voltage. ⁽²⁾
8	HGND	High-side signal ground	High-side analog signal ground; connect this pin to the DCDC_HGND pin.
9	GND	Low-side signal ground	Low-side analog signal ground; connect this pin to the DCDC_GND pin.
10	DOUT	Digital output	Modulator data output.
11	CLKIN	Digital input	Modulator clock input with an internal pulldown resistor (typical value: 1.5MΩ).
12	VDD	Low-side power	Low-side power supply. ⁽¹⁾
13	LDO_OUT	Power	Output of the low-side LDO; connect this pin to the DCDC_IN pin. Do not load the output of the LDO with external circuitry. ⁽¹⁾
14	DIAG	Digital output	Active-low, open-drain status indicator output. Connect this pin to the pullup supply (for example, VDD) using a resistor or leave this pin floating if not used.
15	DCDC_GND	Low-side power ground	Low-side ground reference for the DC/DC converter; connect this pin to the GND pin.
16	DCDC_IN	Power	Low-side input of the DC/DC converter; connect this pin to the LDO_OUT pin. ⁽¹⁾

- (1) See the [Power Supply Recommendations](#) section for power-supply decoupling recommendations.
(2) See the [Layout](#) section for details.

5 Specifications

5.1 Absolute Maximum Ratings

see (1)

		MIN	MAX	UNIT
Power-supply voltage	VDD to GND	-0.3	6.5	V
Analog input voltage	INP, INN	HGND – 6	$V_{HLDO_OUT} + 0.5$	V
Digital input voltage	CLKIN	GND – 0.5	VDD + 0.5	V
Digital output voltage	DOUT	GND – 0.5	VDD + 0.5	V
	DIAG	GND – 0.5	6.5	
Input current	Continuous, any pin except power-supply pins	-10	10	mA
Temperature	Junction, T_J		150	°C
	Storage, T_{stg}	-65	150	

- (1) Operation outside the *Absolute Maximum Ratings* may cause permanent device damage. *Absolute Maximum Ratings* do not imply functional operation of the device at these or any other conditions beyond those listed under *Recommended Operating Conditions*. If used outside the *Recommended Operating Conditions* but within the *Absolute Maximum Ratings*, the device may not be fully functional, and this may affect device reliability, functionality, performance, and shorten the device lifetime

5.2 ESD Ratings

			VALUE	UNIT
$V_{(ESD)}$	Electrostatic discharge	Human-body model (HBM), per AEC Q100-002(1), HBM ESD classification Level 2	±2000	V
		Charged-device model (CDM), per AEC Q100-011, CDM ESD classification Level C6	±1000	

- (1) AEC Q100-002 indicates that HBM stressing shall be in accordance with the ANSI/ESDA/JEDEC JS-001 specification.

5.3 Recommended Operating Conditions

over operating ambient temperature range (unless otherwise noted)

			MIN	NOM	MAX	UNIT
POWER SUPPLY						
VDD	Low-side power supply	VDD to GND	3	3.3	5.5	V
ANALOG INPUT						
$V_{Clipping}$	Differential input voltage before clipping output	$V_{IN} = V_{INP} - V_{INN}$	±64			mV
V_{FSR}	Specified linear differential full-scale voltage	$V_{IN} = V_{INP} - V_{INN}$	-50		50	mV
	Absolute common-mode input voltage (1)	$(V_{INP} + V_{INN}) / 2$ to HGND	-2		V_{HLDO_OUT}	V
V_{CM}	Operating common-mode input voltage	$(V_{INP} + V_{INN}) / 2$ to HGND	-0.032		0.9	V
DIGITAL I/O						
V_{IO}	Digital input / output voltage		0		VDD	V
f_{CLKIN}	Input clock frequency		5	20	21	MHz
	Input clock duty cycle	$5MHz \leq f_{CLKIN} \leq 21MHz$	40%	50%	60%	
TEMPERATURE RANGE						
T_A	Specified ambient temperature		-40		125	°C

- (1) Steady-state voltage supported by the device in case of a system failure. See specified common-mode input voltage V_{CM} for normal operation. Observe analog input voltage range as specified in the *Absolute Maximum Ratings* table.

5.4 Thermal Information

THERMAL METRIC ⁽¹⁾		DWE (SOIC)	UNIT
		16 PINS	
$R_{\theta JA}$	Junction-to-ambient thermal resistance	73.5	°C/W
$R_{\theta JC(top)}$	Junction-to-case (top) thermal resistance	31	°C/W
$R_{\theta JB}$	Junction-to-board thermal resistance	44	°C/W
Ψ_{JT}	Junction-to-top characterization parameter	16.7	°C/W
Ψ_{JB}	Junction-to-board characterization parameter	42.8	°C/W
$R_{\theta JC(bot)}$	Junction-to-case (bottom) thermal resistance	N/A	°C/W

(1) For more information about traditional and new thermal metrics, see the [Semiconductor and IC Package Thermal Metrics](#) application report.

5.5 Power Ratings

PARAMETER		TEST CONDITIONS	VALUE	UNIT
P_D	Maximum power dissipation	VDD = 5.5V	231	mW
		VDD = 3.6V	151	

5.6 Insulation Specifications

over operating ambient temperature range (unless otherwise noted)

PARAMETER		TEST CONDITIONS	VALUE	UNIT
GENERAL				
CLR	External clearance ⁽¹⁾	Shortest pin-to-pin distance through air	≥ 8	mm
CPG	External creepage ⁽¹⁾	Shortest pin-to-pin distance across the package surface	≥ 8	mm
DTI	Distance through insulation	Minimum internal gap (internal clearance - capacitive signal isolation)	≥ 21	μm
DTI	Distance through insulation	Minimum internal gap (internal clearance - transformer power isolation)	≥ 120	μm
CTI	Comparative tracking index	DIN EN 60112 (VDE 0303-11); IEC 60112	≥ 600	V
	Material group	According to IEC 60664-1	I	
	Overvoltage category per IEC 60664-1	Rated mains voltage ≤ 600V _{RMS}	I-III	
		Rated mains voltage ≤ 1000V _{RMS}	I-II	
DIN EN IEC 60747-17 (VDE 0884-17)				
V _{IORM}	Maximum repetitive peak isolation voltage	At AC voltage	1700	V _{PK}
V _{IOWM}	Maximum-rated isolation working voltage	At AC voltage (sine wave)	1200	V _{RMS}
		At DC voltage	1700	V _{DC}
V _{IOTM}	Maximum transient isolation voltage	V _{TEST} = V _{IOTM} , t = 60s (qualification test), V _{TEST} = 1.2 × V _{IOTM} , t = 1s (100% production test)	6000	V _{PK}
V _{IMP}	Maximum impulse voltage ⁽²⁾	Tested in air, 1.2/50μs waveform per IEC 62368-1	7700	V _{PK}
V _{IOSM}	Maximum surge isolation voltage ⁽³⁾	Tested in oil (qualification test), 1.2/50μs waveform per IEC 62368-1	10000	V _{PK}
q _{pd}	Apparent charge ⁽⁴⁾	Method a, after input/output safety test subgroups 2 and 3, V _{pd(ini)} = V _{IOTM} , t _{ini} = 60s, V _{pd(m)} = 1.2 × V _{IORM} , t _m = 10s	≤ 5	pC
		Method a, after environmental tests subgroup 1, V _{pd(ini)} = V _{IOTM} , t _{ini} = 60s, V _{pd(m)} = 1.6 × V _{IORM} , t _m = 10 s	≤ 5	
		Method b1, at preconditioning (type test) and routine test, V _{pd(ini)} = 1.2 × V _{IOTM} , t _{ini} = 1s, V _{pd(m)} = 1.875 × V _{IORM} , t _m = 1s	≤ 5	
		Method b2, at routine test (100% production) ⁽⁶⁾ , V _{pd(ini)} = V _{pd(m)} = 1.2 × V _{IOTM} , t _{ini} = t _m = 1s	≤ 5	
C _{IO}	Barrier capacitance, input to output ⁽⁵⁾	V _{IO} = 0.5 V _{PP} at 1MHz	~4.5	pF
R _{IO}	Insulation resistance, input to output ⁽⁵⁾	V _{IO} = 500 V at T _A = 25°C	> 10 ¹²	Ω
		V _{IO} = 500 V at 100°C ≤ T _A ≤ 125°C	> 10 ¹¹	
		V _{IO} = 500 V at T _S = 150°C	> 10 ⁹	
	Pollution degree		2	
	Climatic category		40/125/21	
UL1577				
V _{ISO}	Withstand isolation voltage	V _{TEST} = V _{ISO} , t = 60s (qualification test), V _{TEST} = 1.2 × V _{ISO} , t = 1s (100% production test)	4250	V _{RMS}

- (1) Apply creepage and clearance requirements according to the specific equipment isolation standards of an application. Maintain the creepage and clearance distance of a board design to make sure that the mounting pads of the isolator on the printed circuit board (PCB) do not reduce this distance. Creepage and clearance on a PCB become equal in certain cases. Techniques such as inserting grooves, ribs, or both on a PCB are used to help increase these specifications.
- (2) Testing is carried out in air to determine the surge immunity of the package.
- (3) Testing is carried in oil to determine the intrinsic surge immunity of the isolation barrier.
- (4) Apparent charge is electrical discharge caused by a partial discharge (pd).
- (5) All pins on each side of the barrier are tied together, creating a two-pin device.
- (6) Either method b1 or b2 is used in production.

5.7 Safety-Related Certifications

VDE	UL
DIN EN IEC 60747-17 (VDE 0884-17), EN IEC 60747-17, DIN EN IEC 62368-1 (VDE 0868-1), EN IEC 62368-1, IEC 62368-1 Clause : 5.4.3 ; 5.4.4.4 ; 5.4.9	Recognized under 1577 component recognition and CSA component acceptance NO 5 programs
Reinforced insulation	Single protection
Certificate number: 40040142	File number: E181974

5.8 Safety Limiting Values

Safety limiting⁽¹⁾ intends to minimize potential damage to the isolation barrier upon failure of input or output circuitry. A failure of the I/O can allow low resistance to ground or the supply and, without current limiting, dissipate sufficient power to over-heat the die and damage the isolation barrier potentially leading to secondary system failures.

PARAMETER		TEST CONDITIONS	MIN	TYP	MAX	UNIT
I _S	Safety input, output, or supply current	R _{θJA} = 73.5°C/W, VDD = 5.5V, T _J = 150°C, T _A = 25°C			309	mA
		R _{θJA} = 73.5°C/W, VDD = 3.6V, T _J = 150°C, T _A = 25°C			472	
P _S	Safety input, output, or total power	R _{θJA} = 73.5°C/W, T _J = 150°C, T _A = 25°C			1700	mW
T _S	Maximum safety temperature				150	°C

- (1) The maximum safety temperature, T_S, has the same value as the maximum junction temperature, T_J, specified for the device. The I_S and P_S parameters represent the safety current and safety power, respectively. Do not exceed the maximum limits of I_S and P_S. These limits vary with the ambient temperature, T_A.

The junction-to-air thermal resistance, R_{θJA}, in the *Thermal Information* table is that of a device installed on a high-K test board for leaded surface-mount packages. Use these equations to calculate the value for each parameter:

$T_J = T_A + R_{\theta JA} \times P$, where P is the power dissipated in the device.

$T_{J(max)} = T_S = T_A + R_{\theta JA} \times P_S$, where T_{J(max)} is the maximum junction temperature.

$P_S = I_S \times VDD_{max}$, where VDD_{max} is the maximum low-side voltage.

5.9 Electrical Characteristics

all minimum and maximum specifications are at $T_A = -40^\circ\text{C}$ to $+125^\circ\text{C}$, $V_{DD} = 3.0\text{V}$ to 5.5V , $I_{NP} = -50\text{mV}$ to $+50\text{mV}$, $I_{NN} = 0\text{V}$, and sinc³ filter with OSR = 256 (unless otherwise noted); typical values are at $T_A = 25^\circ\text{C}$, $CLKIN = 20\text{MHz}$, $V_{DD} = 3.3\text{V}$

PARAMETER		TEST CONDITIONS	MIN	TYP	MAX	UNIT
ANALOG INPUT						
R_{IN}	Single-ended input resistance	$I_{NN} = \text{HGND}$		4.75		k Ω
R_{IND}	Differential input resistance			4.9		k Ω
I_{IB}	Input bias current	$I_{NP} = I_{NN} = \text{HGND}$; $I_{IB} = (I_{IBP} + I_{IBN}) / 2$	-48	-36	-28	μA
I_{IO}	Input offset current ⁽¹⁾	$I_{IO} = I_{IBP} - I_{IBN}$; $I_{NP} = I_{NN} = \text{HGND}$		± 10		nA
C_{IN}	Single-ended input capacitance	$I_{NN} = \text{HGND}$, $f_{IN} = 310\text{kHz}$		4		pF
C_{IND}	Differential input capacitance	$f_{IN} = 310\text{kHz}$		2		pF
ACCURACY						
E_O	Offset error ⁽¹⁾	$I_{NN} = I_{NP} = \text{HGND}$, $T_A = 25^\circ\text{C}$	-50	± 10	50	μV
TCE_O	Offset error thermal drift ⁽⁴⁾	$I_{NN} = I_{NP} = \text{HGND}$	-0.4		0.4	$\mu\text{V}/^\circ\text{C}$
E_G	Gain error	$T_A = 25^\circ\text{C}$	-0.2%	$\pm 0.005\%$	0.2%	
TCE_G	Gain error drift ⁽⁵⁾		-35		35	ppm/ $^\circ\text{C}$
DNL	Differential nonlinearity	Resolution: 16 bits	-0.99		0.99	LSB
INL	Integral nonlinearity	Resolution: 16 bits	-4	± 1	4	LSB
SNR	Signal-to-noise ratio	$f_{IN} = 1\text{kHz}$	77	81		dB
SINAD	Signal-to-noise + distortion	$f_{IN} = 1\text{kHz}$	77	81		dB
THD	Total harmonic distortion ⁽³⁾	$5\text{MHz} \leq f_{CLKIN} \leq 21\text{MHz}$, $f_{IN} = 1\text{kHz}$		-93	-86	dB
SFDR	Spurious-free dynamic range	$f_{IN} = 1\text{kHz}$	87	94		dB
CMRR	Common-mode rejection ratio	$f_{IN} = 0\text{Hz}$, $V_{CM\ min} \leq V_{IN} \leq V_{CM\ max}$		-100		dB
		$f_{IN} = 10\text{kHz}$, $V_{CM\ min} \leq V_{IN} \leq V_{CM\ max}$, $V_{INP} = V_{INN} = 100\text{mV}_{PP}$		-100		
PSRR	Power-supply rejection ratio	V_{DD} from 3.0V to 5.5V, at DC		-120		dB
		$I_{NP} = I_{NN} = \text{HGND}$, V_{DD} from 3.0V to 5.5V, 10kHz, 100mV ripple		-120		
DIGITAL I/O						
I_{IN}	Input leakage current	$\text{GND} \leq V_{IN} \leq V_{DD}$	0		7	μA
C_{IN}	Input capacitance			4		pF
V_{IH}	High-level input voltage		$0.7 \times V_{DD}$		$V_{DD} + 0.3$	V
V_{IL}	Low-level input voltage		-0.3		$0.3 \times V_{DD}$	V
C_{LOAD}	Output load capacitance			15	30	pF
V_{OH}	High-level output voltage	$I_{OH} = -20\mu\text{A}$		$V_{DD} - 0.1$		V
		$I_{OH} = -4\text{mA}$		$V_{DD} - 0.4$		
V_{OL}	Low-level output voltage	$I_{OL} = 20\mu\text{A}$			0.1	V
		$I_{OL} = 4\text{mA}$			0.4	
CMTI	Common-mode transient immunity		75	135		kV/ μs

5.9 Electrical Characteristics (continued)

all minimum and maximum specifications are at $T_A = -40^\circ\text{C}$ to $+125^\circ\text{C}$, $V_{DD} = 3.0\text{V}$ to 5.5V , $INP = -50\text{mV}$ to $+50\text{mV}$, $INN = 0\text{V}$, and sinc³ filter with $OSR = 256$ (unless otherwise noted); typical values are at $T_A = 25^\circ\text{C}$, $CLKIN = 20\text{MHz}$, $V_{DD} = 3.3\text{V}$

PARAMETER		TEST CONDITIONS	MIN	TYP	MAX	UNIT
POWER SUPPLY						
IDD	Low-side supply current	No external load on HLDO		26	40	mA
		1mA external load on HLDO		28	42	
V _{DCDC_OUT}	DC/DC output voltage	DCDC_OUT to HGND	3.1	3.5	4.65	V
V _{DCDCUV}	DC/DC output undervoltage detection threshold voltage	V _{DCDC_OUT} falling	2.1	2.25		V
V _{HLDO_OUT}	High-side LDO output voltage	HLDO_OUT to HGND, up to 1mA external load ⁽²⁾	3	3.2	3.4	V
V _{HLDOUV}	High-side LDO output undervoltage detection threshold voltage	V _{HLDO_OUT} falling	2.4	2.6		V
I _H	High-side supply current for auxiliary circuitry	Load connected from HLDO_OUT to HGND; non-switching; $-40^\circ\text{C} \leq T_A \leq 85^\circ\text{C}$ ⁽²⁾			1	mA
t _{START}	Device startup time	VDD step to 3.0V to bitstream valid		0.9	1.4	ms

- (1) The typical value includes one sigma statistical variation at nominal operating conditions.
- (2) High-side LDO supports external loads only up to $T_A = 85^\circ\text{C}$. See the *Isolated DC/DC Converter* section for more details.
- (3) THD is the ratio of the rms sum of the amplitudes of first five higher harmonics to the amplitude of the fundamental.
- (4) Offset error temperature drift is calculated using the box method, as described by the following equation:

$$TCE_O = (E_{O,MAX} - E_{O,MIN}) / TempRange$$
 where $E_{O,MAX}$ and $E_{O,MIN}$ refer to the maximum and minimum E_O values measured within the temperature range (-40 to 125°C).
- (5) Gain error temperature drift is calculated using the box method, as described by the following equation:

$$TCE_G (ppm) = ((E_{G,MAX} - E_{G,MIN}) / TempRange) \times 10^4$$
 where $E_{G,MAX}$ and $E_{G,MIN}$ refer to the maximum and minimum E_G values (in %) measured within the temperature range (-40 to 125°C).

5.10 Switching Characteristics

PARAMETER	TEST CONDITIONS	MIN	TYP	MAX	UNIT
t_H	DOUT hold time after rising edge of CLKIN	$C_{LOAD} = 15pF$		3.5	ns
t_D	Rising edge of CLKIN to DOUT valid delay	$C_{LOAD} = 15pF$; CLKIN 50% to DOUT 10% / 90%		15	ns
t_r	DOUT rise time	10% to 90%, $3.0V \leq VDD \leq 3.6V$, $C_{LOAD} = 15pF$		2.5	6
		10% to 90%, $4.5V \leq VDD \leq 5.5V$, $C_{LOAD} = 15pF$		3.2	
t_f	DOUT fall time	10% to 90%, $3.0V \leq VDD \leq 3.6V$, $C_{LOAD} = 15pF$		2.2	6
		10% to 90%, $4.5V \leq VDD \leq 5.5V$, $C_{LOAD} = 15pF$		2.9	

5.11 Timing Diagrams

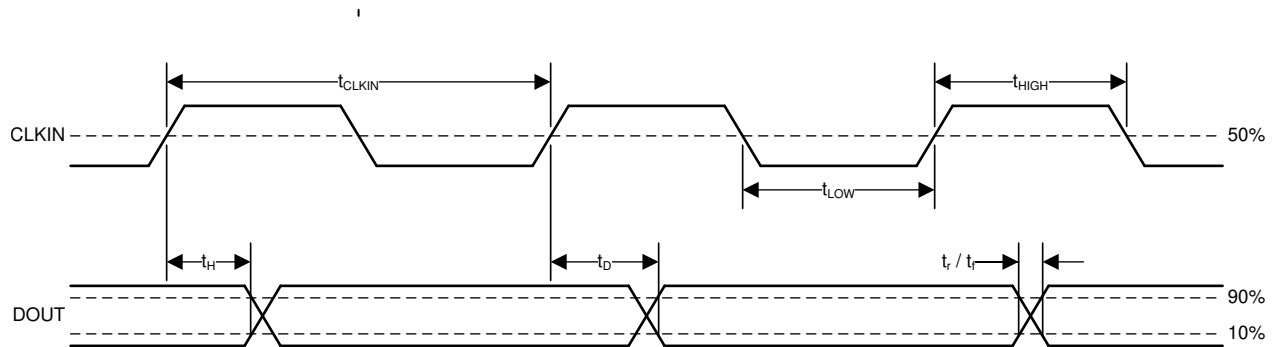

Figure 5-1. Digital Interface Timing

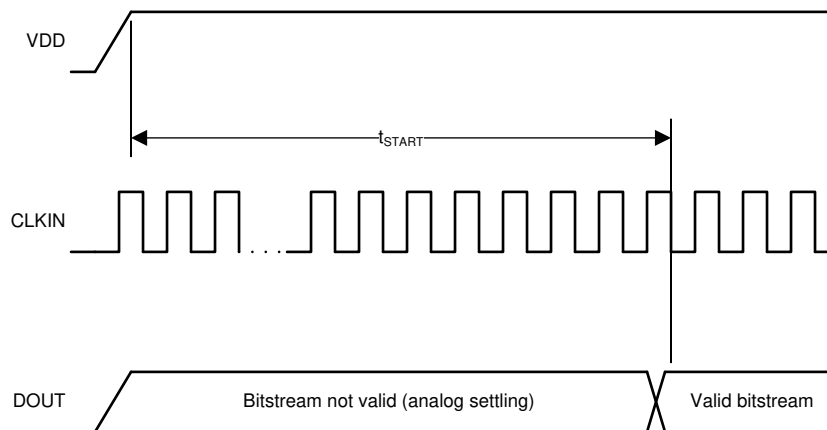
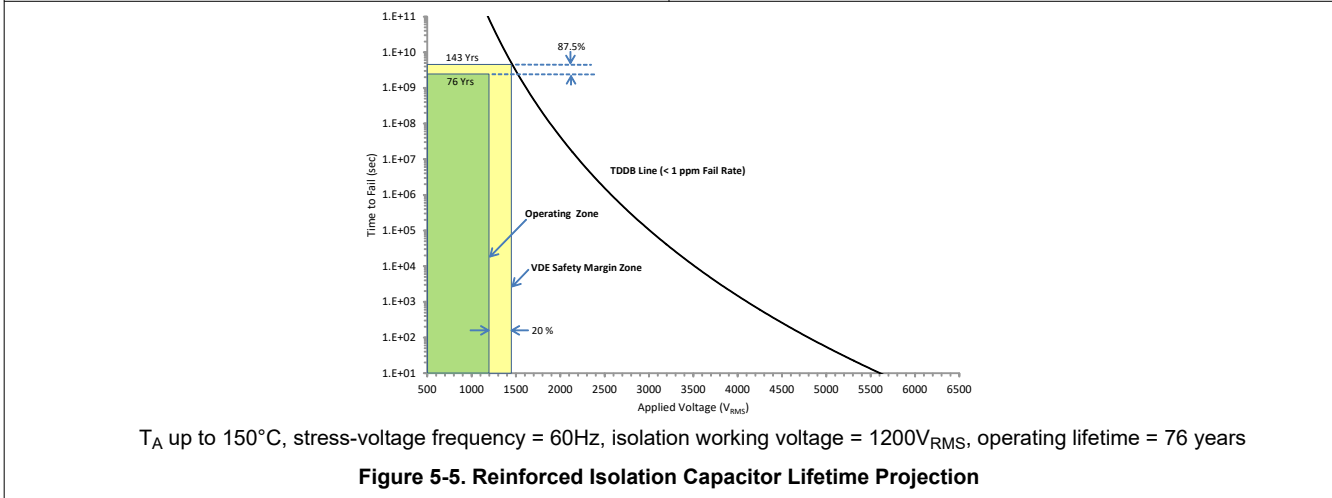
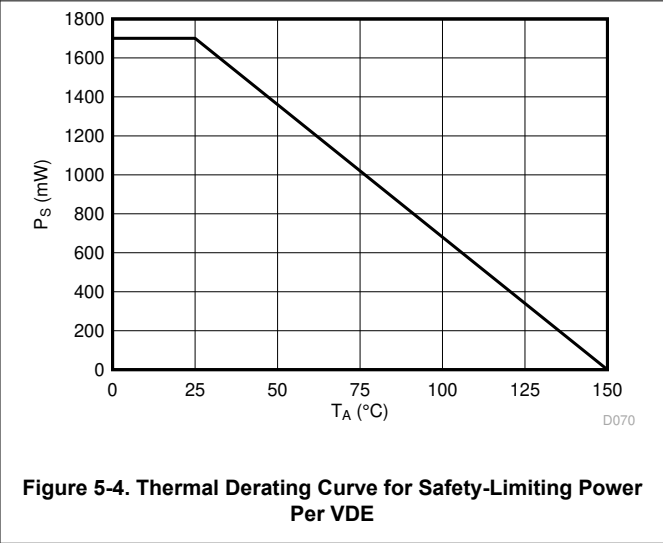
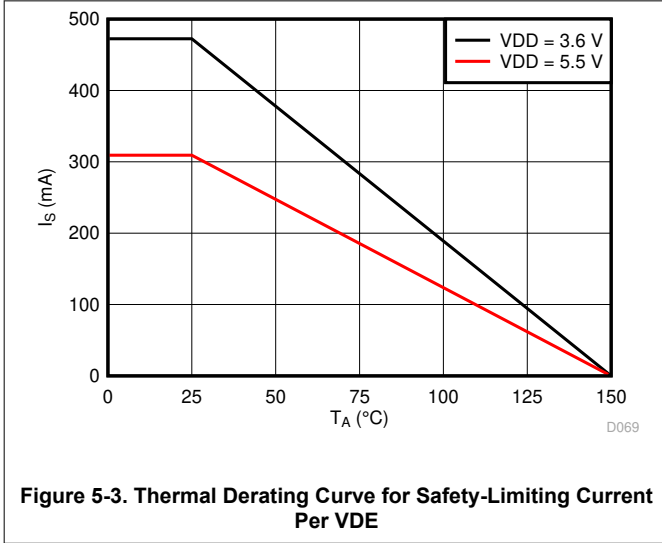

Figure 5-2. Device Start-Up Timing

5.12 Insulation Characteristics Curves



5.13 Typical Characteristics

at VDD = 3.3V, INP = -50mV to +50mV, INN = HGND, f_{CLKIN} = 20MHz, and sinc³ filter with OSR = 256, and 16-bit resolution (unless otherwise noted)

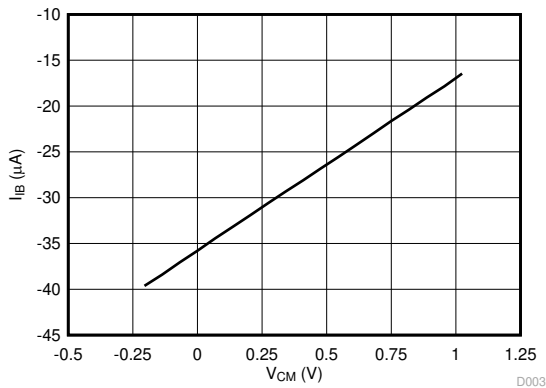

Figure 5-6. Input Bias Current vs Common-Mode Input Voltage

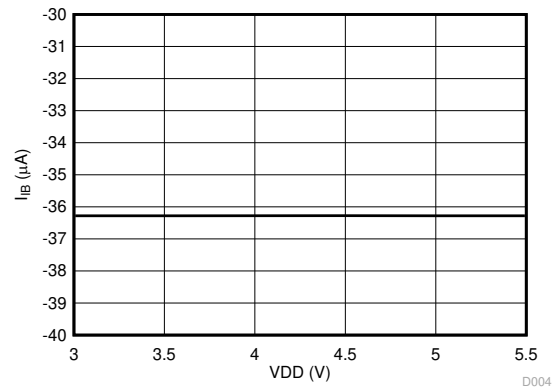

Figure 5-7. Input Bias Current vs Supply Voltage

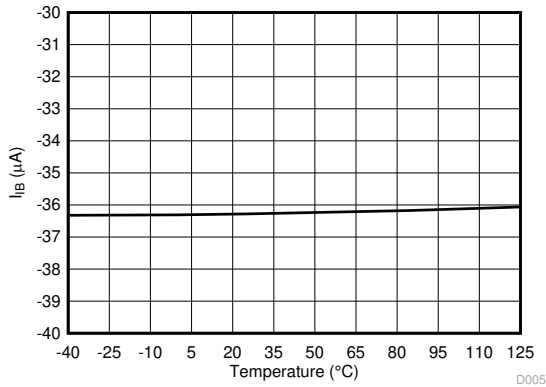

Figure 5-8. Input Bias Current vs Temperature

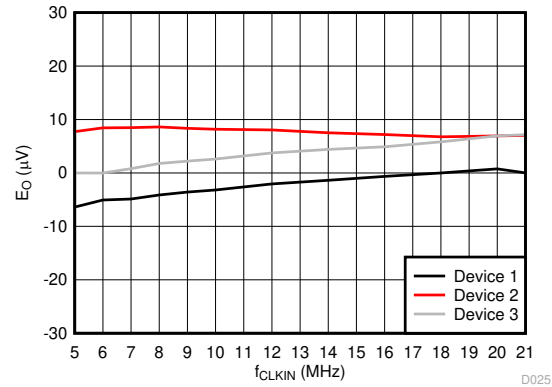

Figure 5-9. Offset Error vs Input Clock Frequency

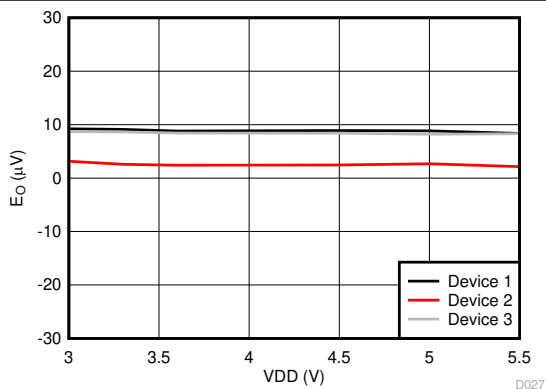

Figure 5-10. Offset Error vs Supply Voltage

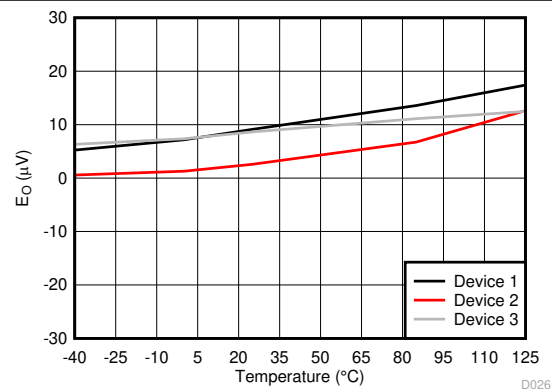

Figure 5-11. Offset Error vs Temperature

5.13 Typical Characteristics (continued)

at VDD = 3.3V, INP = -50mV to +50mV, INN = HGND, f_{CLKIN} = 20MHz, and sinc³ filter with OSR = 256, and 16-bit resolution (unless otherwise noted)

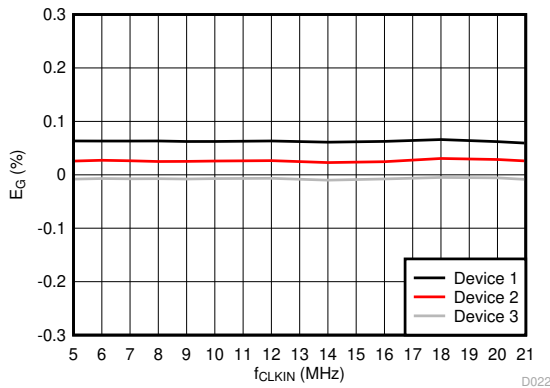

Figure 5-12. Gain Error vs Input Clock Frequency

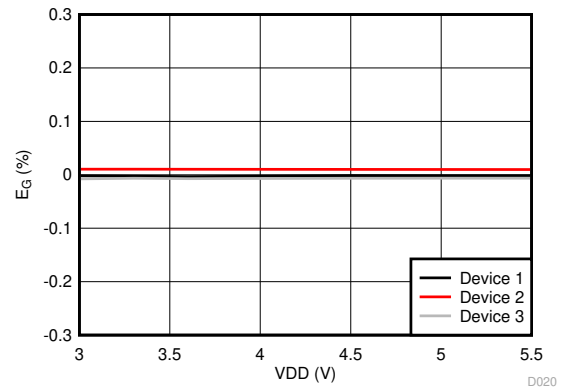

Figure 5-13. Gain Error vs Supply Voltage

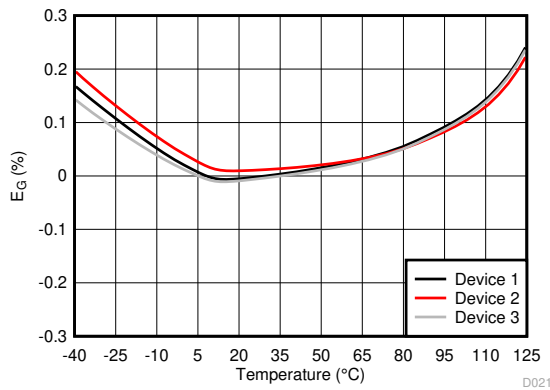

Figure 5-14. Gain Error vs Temperature



Figure 5-15. Integral Nonlinearity vs Input Voltage

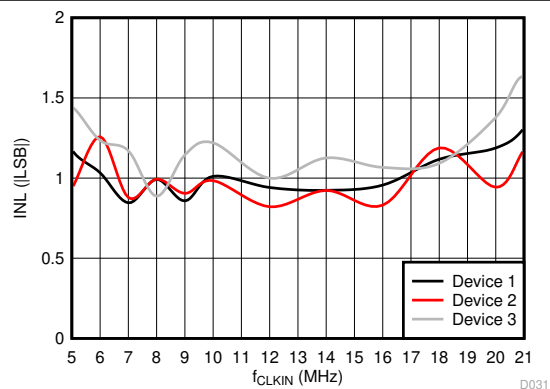

Figure 5-16. Integral Nonlinearity vs Input Clock Frequency

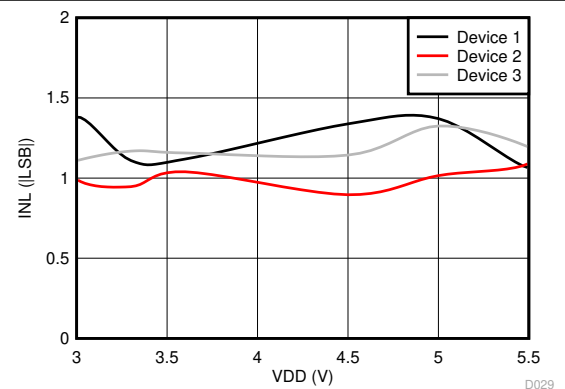

Figure 5-17. Integral Nonlinearity vs Supply Voltage

5.13 Typical Characteristics (continued)

at VDD = 3.3V, INP = -50mV to +50mV, INN = HGND, f_{CLKIN} = 20MHz, and sinc³ filter with OSR = 256, and 16-bit resolution (unless otherwise noted)

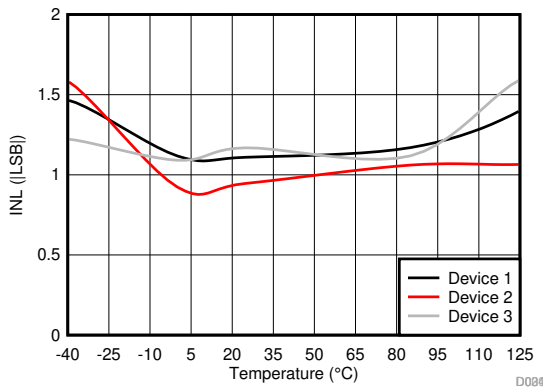

Figure 5-18. Integral Nonlinearity vs Temperature

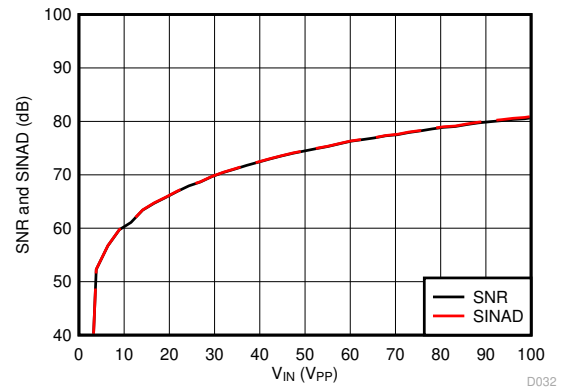

Figure 5-19. Signal-to-Noise Ratio and Signal-to-Noise + Distortion vs Input Signal Amplitude

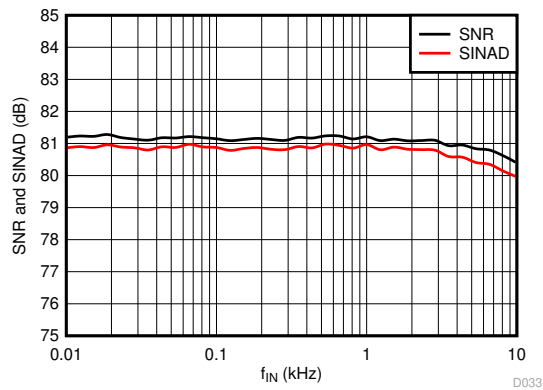

Figure 5-20. Signal-to-Noise Ratio and Signal-to-Noise + Distortion vs Input Signal Frequency

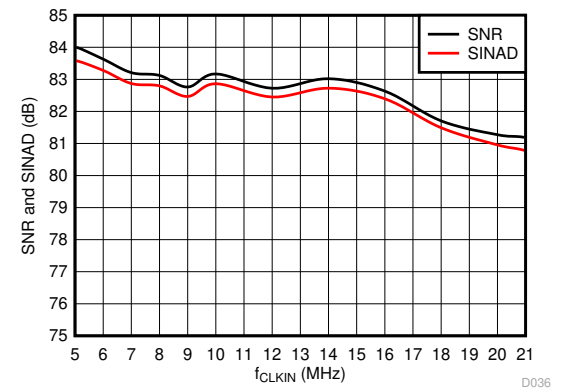

Figure 5-21. Signal-to-Noise Ratio and Signal-to-Noise + Distortion vs Input Clock Frequency

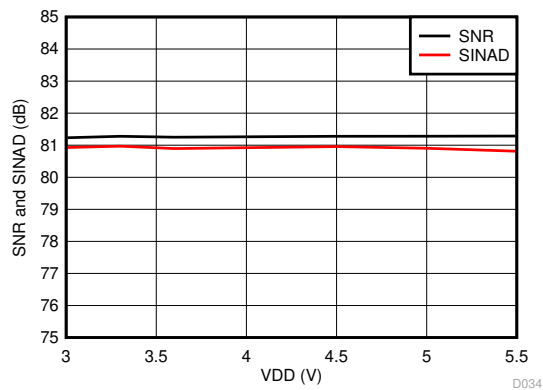

Figure 5-22. Signal-to-Noise Ratio and Signal-to-Noise + Distortion vs Supply Voltage

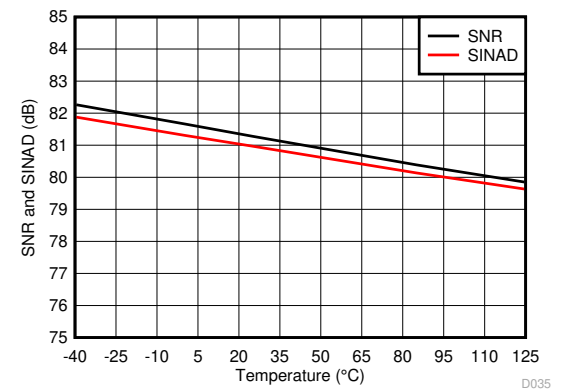

Figure 5-23. Signal-to-Noise Ratio and Signal-to-Noise + Distortion vs Temperature

5.13 Typical Characteristics (continued)

at $V_{DD} = 3.3V$, $INP = -50mV$ to $+50mV$, $INN = HGND$, $f_{CLKIN} = 20MHz$, and sinc³ filter with OSR = 256, and 16-bit resolution (unless otherwise noted)

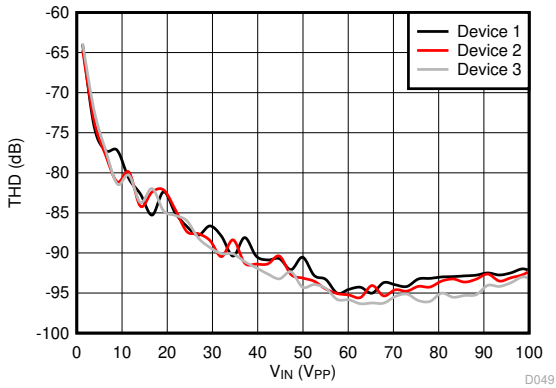

Figure 5-24. Total Harmonic Distortion vs Input Signal Amplitude

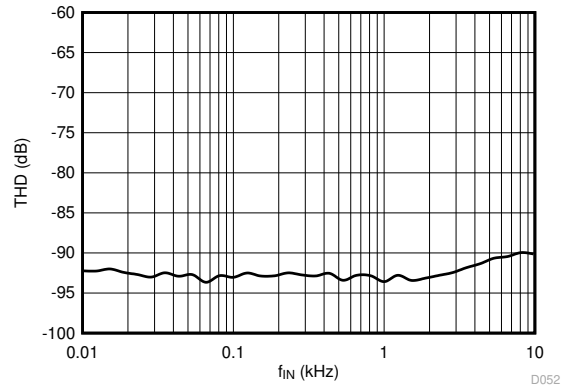

Figure 5-25. Total Harmonic Distortion vs Input Signal Frequency

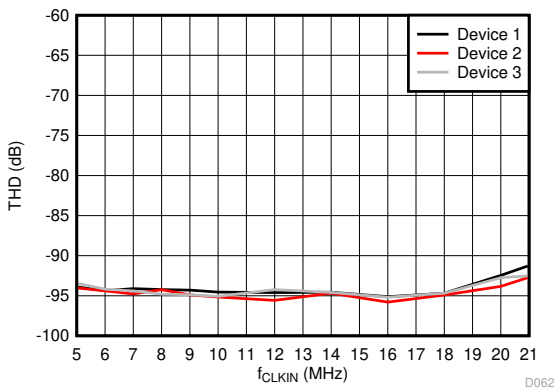

Figure 5-26. Total Harmonic Distortion vs Input Clock Frequency

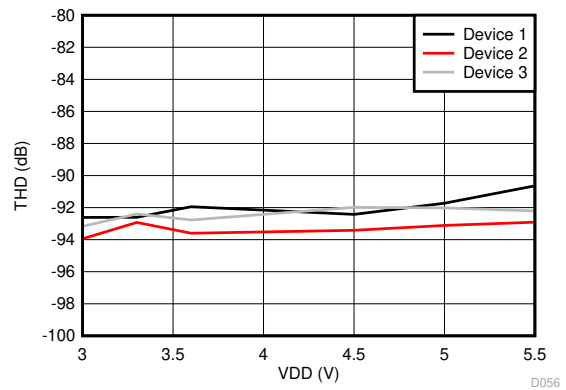

Figure 5-27. Total Harmonic Distortion vs Supply Voltage

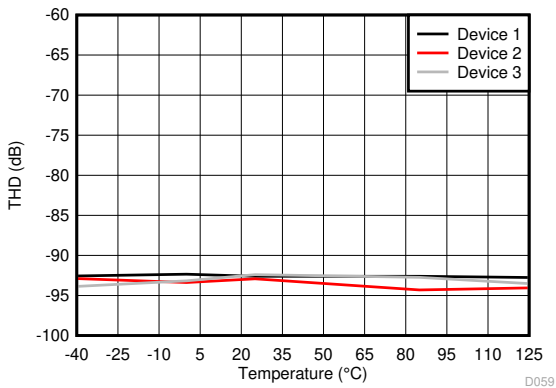

Figure 5-28. Total Harmonic Distortion vs Temperature

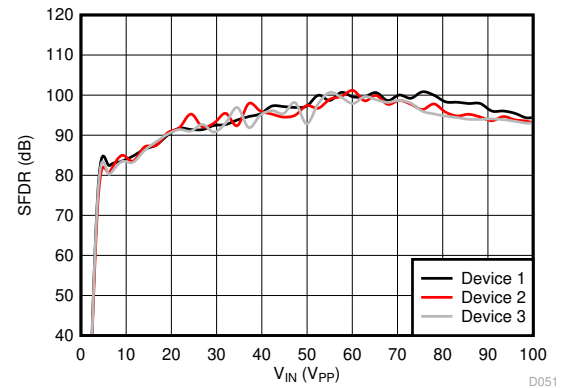

Figure 5-29. Spurious-Free Dynamic Range vs Input Signal Amplitude

5.13 Typical Characteristics (continued)

at VDD = 3.3V, INP = -50mV to +50mV, INN = HGND, f_{CLKIN} = 20MHz, and sinc³ filter with OSR = 256, and 16-bit resolution (unless otherwise noted)

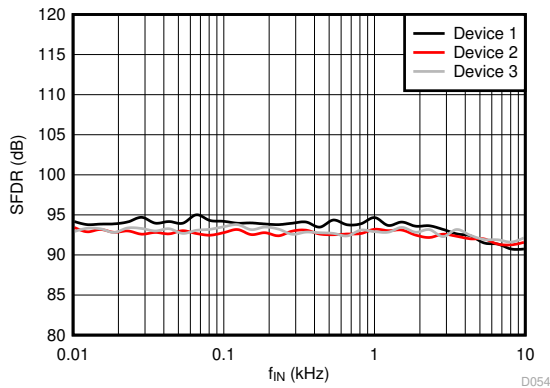

Figure 5-30. Spurious-Free Dynamic Range vs Input Signal Frequency

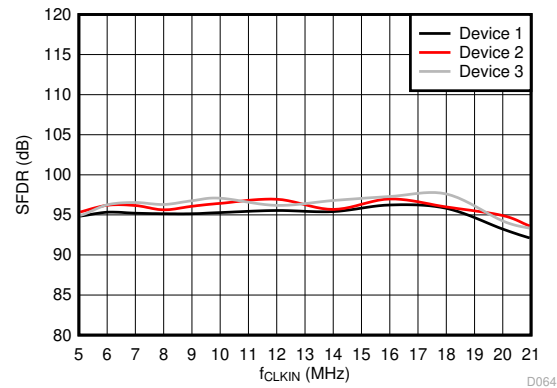

Figure 5-31. Spurious-Free Dynamic Range vs Input Clock Frequency

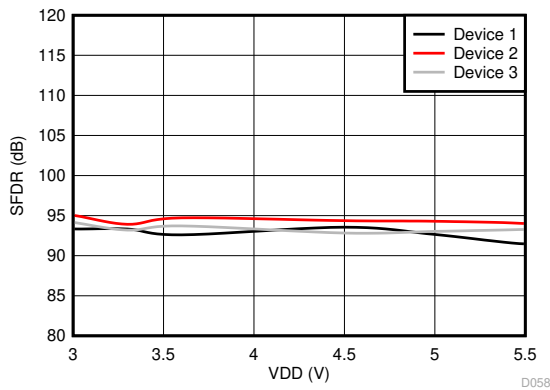

Figure 5-32. Spurious-Free Dynamic Range vs Supply Voltage

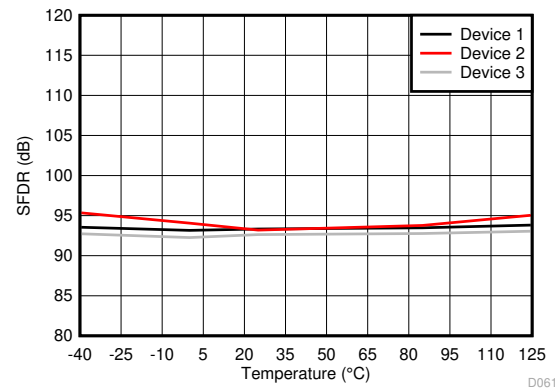

Figure 5-33. Spurious-Free Dynamic Range vs Temperature

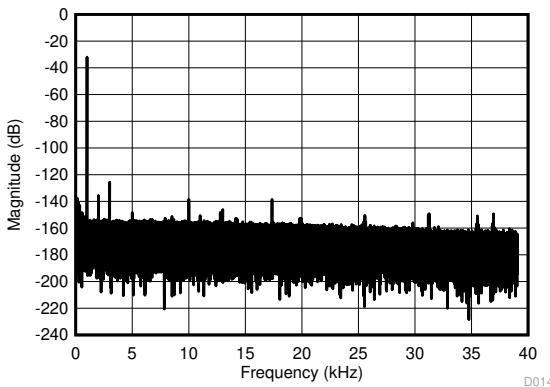

Figure 5-34. Output Frequency Spectrum With a 1kHz Input Signal

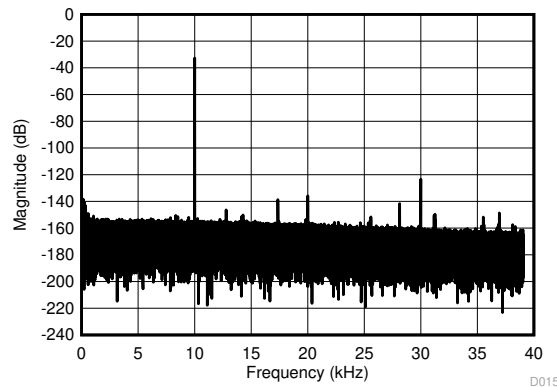

Figure 5-35. Output Frequency Spectrum With a 10kHz Input Signal

5.13 Typical Characteristics (continued)

at VDD = 3.3V, INP = -50mV to +50mV, INN = HGND, f_{CLKIN} = 20MHz, and sinc³ filter with OSR = 256, and 16-bit resolution (unless otherwise noted)

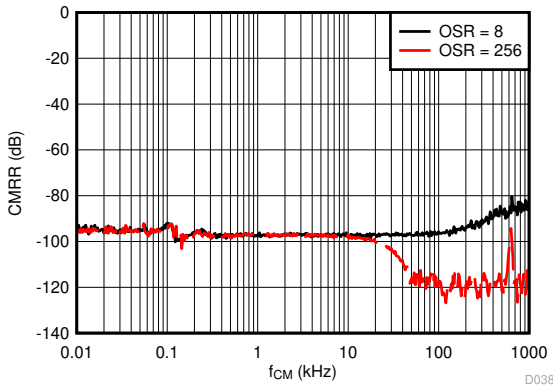

Figure 5-36. Common-Mode Rejection Ratio vs Input Signal Frequency

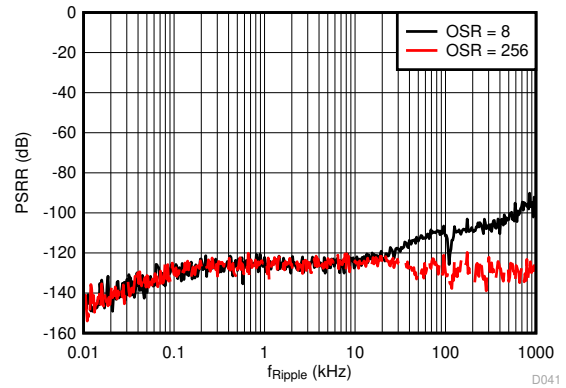

Figure 5-37. Power-Supply Rejection Ratio vs Ripple Frequency

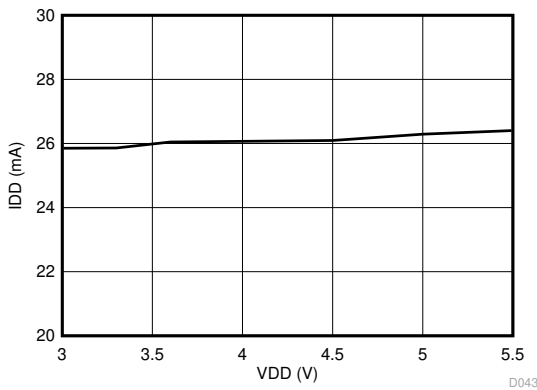

Figure 5-38. Supply Current vs Supply Voltage

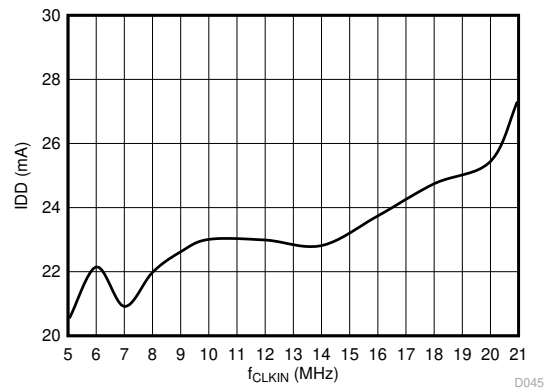

Figure 5-39. Supply Current vs Input Clock Frequency

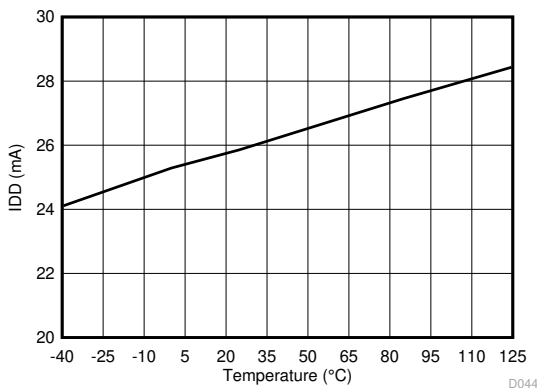

Figure 5-40. Supply Current vs Temperature

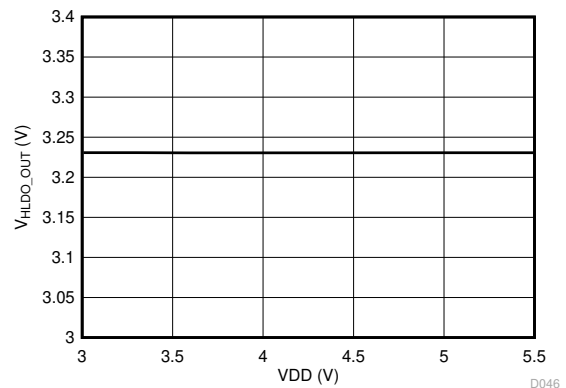

Figure 5-41. High-Side LDO Output Voltage vs Supply Voltage

5.13 Typical Characteristics (continued)

at VDD = 3.3V, INP = -50mV to +50mV, INN = HGND, $f_{CLKIN} = 20\text{MHz}$, and sinc³ filter with OSR = 256, and 16-bit resolution (unless otherwise noted)

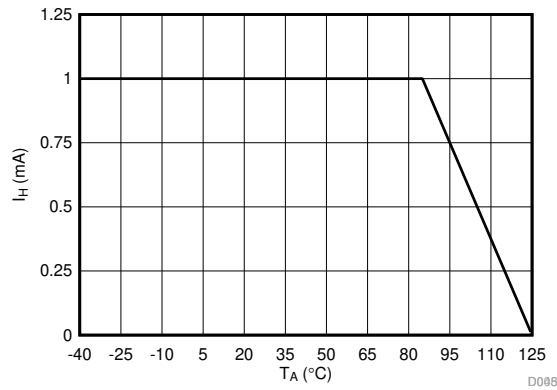

Figure 5-42. I_H Derating vs Ambient Temperature

6 Detailed Description

6.1 Overview

The AMC3306M05-Q1 is a fully differential, precision, isolated modulator with an integrated DC/DC converter. The converter supplies the high side of the device from a single 3.3V or 5V voltage supply on the low side. The analog input pins INP and INN are connected to a fully differential amplifier that feeds the switched-capacitor input of a second-order, delta-sigma ($\Delta\Sigma$) modulator. The modulator converts the analog input signal into a digital bitstream that is transferred across the isolation barrier. The isolated data output DOUT of the converter provides a stream of digital ones and zeros. This data stream is synchronous to the externally provided clock source at the CLKIN pin. The time average of this serial bitstream output is proportional to the analog input voltage. The external clock input simplifies the synchronization of multiple current-sensing channels on the system level.

The signal path is isolated by a double capacitive silicon dioxide (SiO_2) insulation barrier. Power isolation, however, uses an on-chip transformer separated by a thin-film polymer as the insulating material.

6.2 Functional Block Diagram

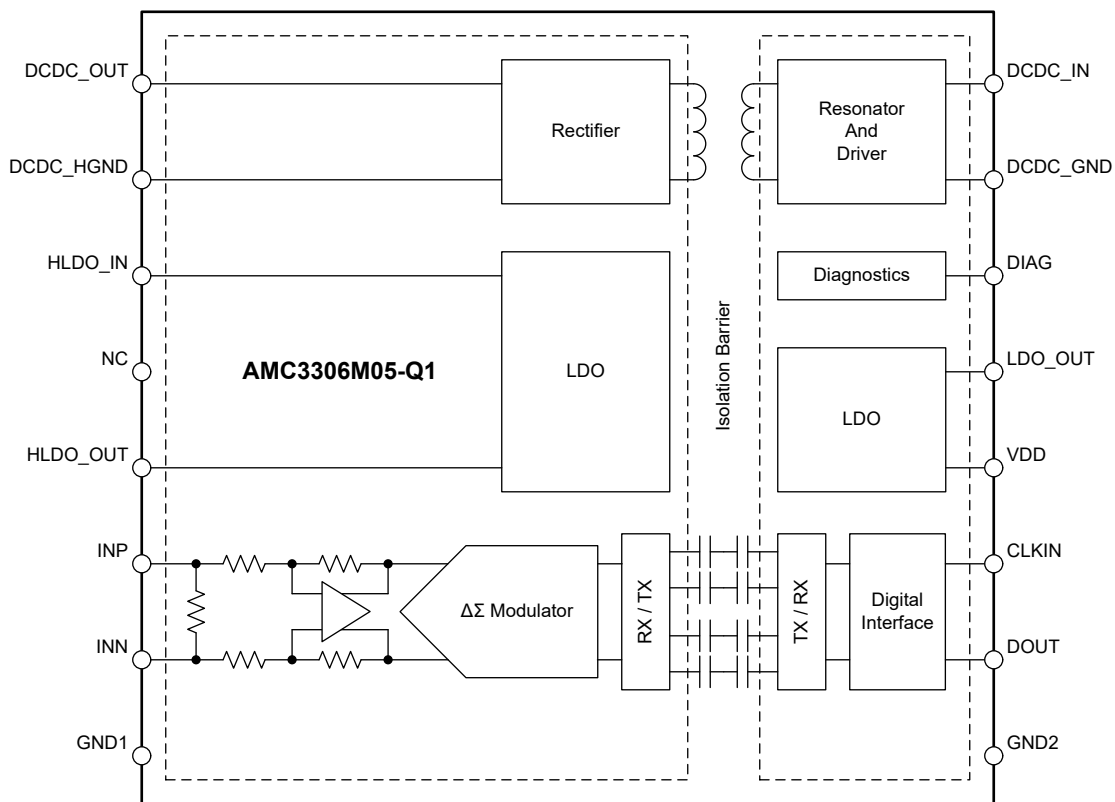

6.3 Feature Description

6.3.1 Analog Input

The differential amplifier input stage of the AMC3306M05-Q1 feeds a second-order, switched-capacitor, feed-forward $\Delta\Sigma$ modulator. The gain of the differential amplifier is set by internal precision resistors with a differential input impedance of R_{IND} . The modulator converts the analog input signal into a bitstream that is transferred across the isolation barrier. See the [Isolation Channel Signal Transmission](#) section.

For reduced offset and offset drift, the differential amplifier is chopper-stabilized with the switching frequency set at $f_{CLKIN} / 32$. As shown in [Figure 6-1](#), the switching frequency generates a spur at 625kHz.

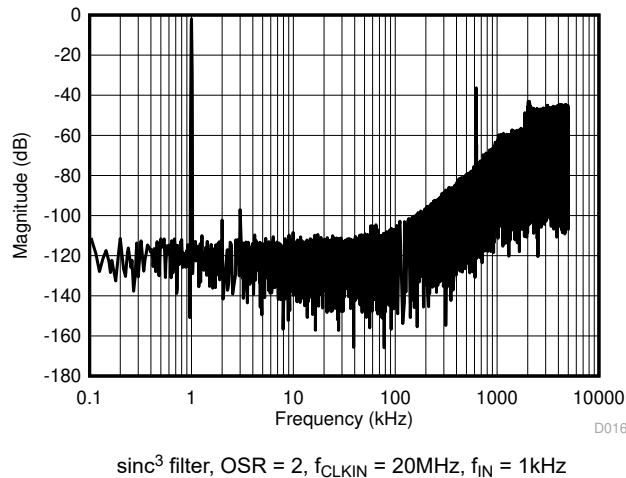

Figure 6-1. Quantization Noise Shaping

There are two restrictions on the analog input signals INP and INN. First, if the input voltages V_{INP} or V_{INN} exceed the range specified in the [Absolute Maximum Ratings](#) table, limit the input currents to the absolute maximum value. Otherwise, the electrostatic discharge (ESD) protection turns on. In addition, the device linearity and parametric performance are specified only when the analog input voltage remains within the V_{FSR} and V_{CM} ranges. The [Recommended Operating Conditions](#) table describes the linear full-scale range (V_{FSR}) and the common-mode input voltage range (V_{CM}).

6.3.2 Modulator

Figure 6-2 conceptualizes the second-order, switched-capacitor, feed-forward $\Delta\Sigma$ modulator implemented in the AMC3306M05-Q1. The output V_5 of the 1-bit, digital-to-analog converter (DAC) is subtracted from the input voltage $V_{IN} = (V_{INN} - V_{INP})$ and results in a voltage V_1 . V_1 feeds the input of the first integrator stage. The output of the first integrator feeds the input of the second integrator stage, resulting in an output voltage V_3 . V_3 is summed with the input signal V_{IN} and the output of the first integrator V_2 . Depending on the polarity of the resulting voltage V_4 , the output of the comparator is changed. In this case, the 1-bit DAC responds on the next clock pulse by changing the associated analog output voltage V_5 . This change causes the integrators to progress in the opposite direction and forces the value of the integrator output to track the average input value.

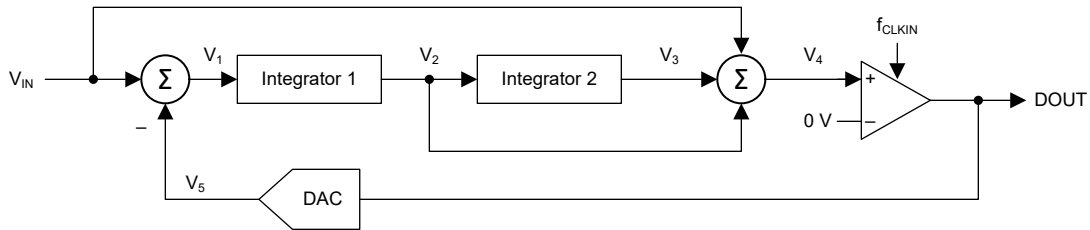

Figure 6-2. Block Diagram of a Second-Order Modulator

The modulator shifts the quantization noise to high frequencies, as illustrated in Figure 6-1. Therefore, use a low-pass digital filter, such as a SINC filter, at the output of the device to increase signal to noise ratio. This filter also converts the 1-bit data stream at a high sampling rate into a higher-bit data word at a lower rate (decimation). TI's C2000™ and Sitara™ microcontroller families offer a suitable programmable, hardwired filter structure termed a *sigma-delta filter module* (SDFM) optimized for usage with the AMC3306M05-Q1. Alternatively, use a field-programmable gate array (FPGA) or complex programmable logic device (CPLD) to implement the filter.

6.3.3 Isolation Channel Signal Transmission

The AMC3306M05-Q1 uses an on-off keying (OOK) modulation scheme, as shown in Figure 6-3, to transmit the modulator output bitstream across the SiO₂-based isolation barrier. The transmit driver (TX) shown in the [Functional Block Diagram](#) transmits an internally generated, high-frequency carrier across the isolation barrier to represent a digital *one*. However, TX does not send a signal to represent a digital *zero*. The nominal frequency of the carrier used inside the AMC3306M05-Q1 is 480MHz.

The receiver (RX) on the other side of the isolation barrier recovers and demodulates the signal and produces the output. The AMC3306M05-Q1 transmission channel is optimized to achieve the highest level of common-mode transient immunity (CMTI). This channel is also optimized to achieve the lowest level of radiated emissions caused by the high-frequency carrier and RX/TX buffer switching.

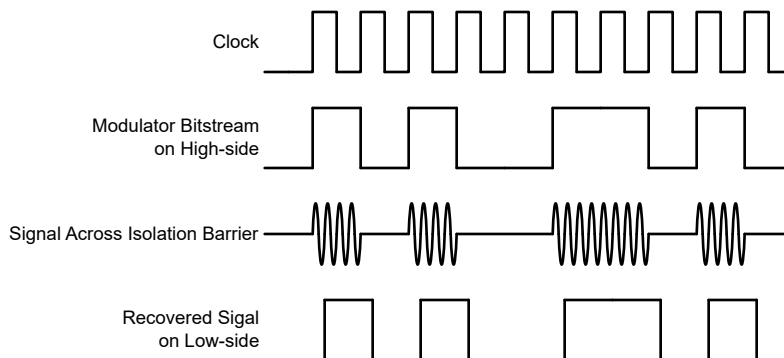

Figure 6-3. OOK-Based Modulation Scheme

6.3.4 Digital Output

A differential input signal of 0V ideally produces a stream of ones and zeros that are high 50% of the time. A differential input of 50mV produces a stream of ones and zeros that are high 89.06% of the time. With 16 bits of resolution, that percentage corresponds to code 58368. A differential input of –50mV produces a stream of ones and zeros that are high 10.94% of the time and results in code 7168. These input voltages are also the specified linear range of the AMC3306M05-Q1. If the input voltage value exceeds this range, the output of the modulator shows nonlinear behavior as the quantization noise increases. The modulator output clips with constant stream of zeros with an input $\leq -64\text{mV}$. In this case, the AMC3306M05-Q1 generates a single 1 every 128 clock cycles to indicate proper device function. The modulator output clips with constant stream of ones with an input $\geq 64\text{mV}$. In this case, the AMC3306M05-Q1 generates a single 0 every 128 clock cycles to indicate proper device function. See the [Output Behavior in Case of a Full-Scale Input](#) section for more details. [Figure 6-4](#) shows the input voltage versus the output modulator signal.

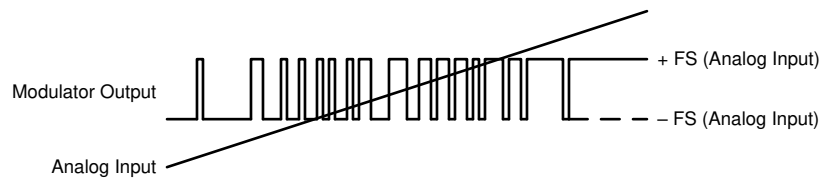

Figure 6-4. AMC3306M05-Q1 Modulator Output vs Analog Input

Calculate the density of ones in the output bitstream with [Equation 1](#) for any input voltage value except a full-scale input signal. See the [Output Behavior in Case of a Full-Scale Input](#) section.

$$\frac{V_{IN} + V_{Clipping}}{2 \times V_{Clipping}} \quad (1)$$

6.3.4.1 Output Behavior in Case of a Full-Scale Input

The device generates a single one or zero every 128 bits at DOUT if an input signal is applied that exceeds the clipping voltage. This voltage is defined as ($|V_{IN}| \geq V_{Clipping}$). [Figure 6-5](#) shows the full-scale output timing, which is dependent on the actual polarity of the signal being sensed. In this way, differentiating between a missing high-side supply and a full-scale input signal is possible on the system level.

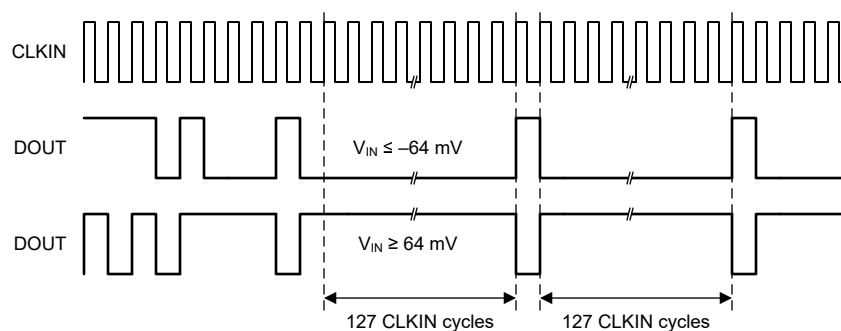

Figure 6-5. Full-Scale Output of the AMC3306M05-Q1

6.3.4.2 Output Behavior in Case of a High-Side Supply Failure

The device output DOUT is a constant bitstream of logic 0's whenever the integrated DC/DC converter output voltage is below the undervoltage detection threshold. See the [Diagnostic Output](#) section for more information.

6.3.5 Isolated DC/DC Converter

The AMC3306M05-Q1 offers a fully integrated, isolated DC/DC converter with the following components(see the [Functional Block Diagram](#) section):

- Low-dropout regulator (LDO) on the low side to stabilize the supply voltage VDD that drives the low side of the converter. This circuit does not output a constant voltage and is not intended for driving any external load.
- Low-side full-bridge inverter and drivers.
- Laminate-based, air-core transformer for high immunity to magnetic fields.
- High-side full-bridge rectifier.
- High-side LDO to stabilize the output voltage of the DC/DC converter for high analog performance of the signal path. The high-side LDO outputs a constant voltage and optionally provides a limited amount of current to power external circuitry.

The DC/DC converter uses a spread-spectrum clock generation technique to reduce the spectral density of the electromagnetic radiation. The resonator frequency is synchronized to the $\Delta\Sigma$ modulator operation to minimize interference with data transmission and support high analog performance of the device.

The architecture of the DC/DC converter is optimized to drive the high-side circuitry of the AMC3306M05-Q1. The DC/DC converter sources up to I_H of additional DC current to power an optional active filter, preamplifier, or isolated comparator (such as the [AMC23C12-Q1](#)). As shown in [Figure 6-6](#), I_H is specified up to an ambient temperature of 85°C and derates linearly at higher temperatures.

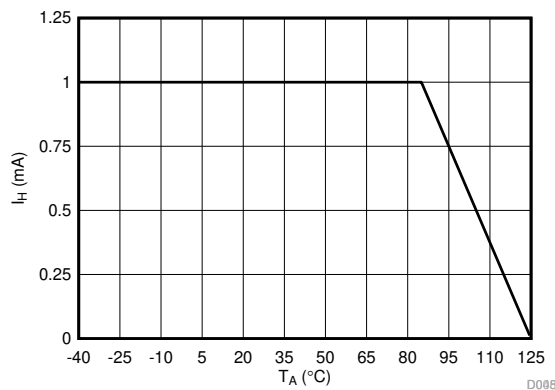

Figure 6-6. Derating of I_H at Ambient Temperatures >85°C

6.3.6 Diagnostic Output

As shown in [Figure 6-7](#), monitor the open-drain DIAG pin to confirm the device is operational and the output data are valid. During power-up, the DIAG pin is actively held low until the high-side supply is in regulation and the modulator starts outputting data. The DIAG pin is actively pulled low if:

- The low side does not receive data from the high side (for example, because of a loss of power on the high side). The modulator outputs a constant bitstream of logic 0's in this case, that is, the DOUT pin is permanently low.
- The high-side DC/DC output voltage (DCDC_OUT) or the high-side LDO output voltage (HLDO_OUT) drop below the respective undervoltage detection thresholds (brown-out). In this case, the low-side still receives data from the high-side but the data is potentially invalid. However, the modulator outputs a constant bitstream of logic 0's in this case, meaning that the DOUT pin is permanently low.

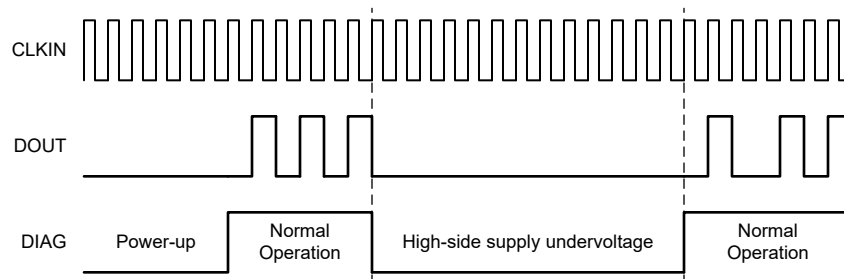

Figure 6-7. DIAG and Output Under Different Operating Conditions

6.4 Device Functional Modes

The AMC3306M05-Q1 is operational when VDD is applied, as specified in the [Recommended Operating Conditions](#) table.

7 Application and Implementation

Note

Information in the following applications sections is not part of the TI component specification, and TI does not warrant its accuracy or completeness. TI's customers are responsible for determining suitability of components for their purposes, as well as validating and testing their design implementation to confirm system functionality.

7.1 Application Information

The AMC3306M05-Q1 is a high-performance solution for shunt-based current sensing in the presence of high common-mode voltage levels.

7.1.1 Digital Filter Usage

The modulator generates a bitstream that is required to be processed by a digital filter. This process obtains a digital word similar to a conversion result of a conventional analog-to-digital converter (ADC). A very simple filter, as shown in [Equation 2](#), built with minimal effort and hardware, is a sinc³-type filter:

$$H(z) = \left(\frac{1 - z^{-\text{OSR}}}{1 - z^{-1}} \right)^3 \quad (2)$$

This filter provides the best output performance at the lowest hardware size (count of digital gates) for a second-order modulator. All characterization in this document is done with a 256 OSR sinc³ filter and a 16-bit output word width, unless otherwise noted. The measured effective number of bits (ENOB) as a function of the OSR is illustrated in [Figure 7-3](#) of the [Typical Application](#) section.

A [delta sigma modulator filter calculator](#) is available for download at www.ti.com. This calculator aids in the filter design and correct OSR and filter-order selection to achieve the desired output resolution and filter response time.

The [Combining the ADS1202 with an FPGA Digital Filter for Current Measurement in Motor Control Applications application note](#), available at www.ti.com, discusses an example code. This example code implements a sinc³ filter in an FPGA.

7.2 Typical Application

7.2.1 Onboard Charger (OBC) Application

The AMC3306M05-Q1 is designed for shunt-based, current-sensing applications where accurate current monitoring is required in the presence of high common-mode voltages. The AMC3306M05-Q1 integrates an isolated power supply for the high-voltage side. This feature makes the device particularly easy to use in applications without a high-side supply readily available

Figure 7-1 shows a simplified schematic using the AMC3306M05-Q1 to measure the output current of a PFC stage of an onboard charger (OBC). At this location in the system, there is no supply readily available for powering the high side of the isolated amplifier. The integrated isolated power supply solves this problem and, with the bipolar input voltage range, makes the AMC3306M05-Q1 an easy-to-use solution for bidirectional current sensing. In this example, the AC line voltage is sensed by the AMC3336-Q1 on the grid side. On this side, there is no suitable supply available for powering the high side of the isolated amplifier. The integrated power supply, high input impedance, and bipolar input voltage range of the AMC3336-Q1 makes the device a compact solution for AC voltage-sensing applications.

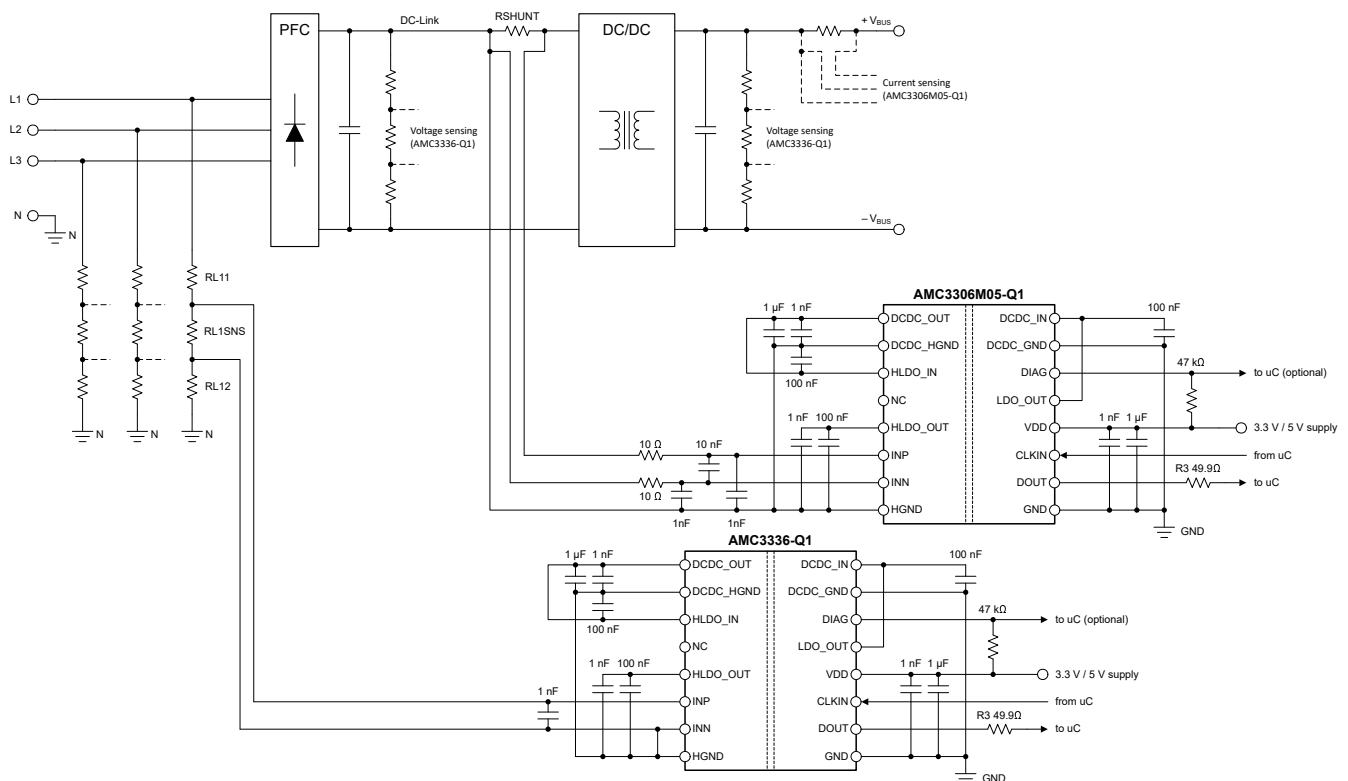

Figure 7-1. The AMC3306M05-Q1 in an OBC Application

7.2.1.1 Design Requirements

Table 7-1 lists the parameters for this typical application.

Table 7-1. Design Requirements

PARAMETER	VALUE
Low-side supply voltage	3.3V or 5V
Voltage drop across RSHUNT for a linear response	±50mV (maximum)

7.2.1.2 Detailed Design Procedure

The AMC3306M05-Q1 requires a single 3.3V or 5V supply on the low side. The high-side supply is internally generated by an integrated DC/DC converter as explained in the [Isolated DC/DC Converter](#) section.

The ground reference (HGND) is derived from the terminal of the shunt resistor connected to the negative input (INN) of the AMC3306M05-Q1. If using a four-pin shunt, connect the inputs of the AMC3306M05-Q1 to the sense terminals of the shunt. Route the ground connection as a separate trace to the shunt to minimize offset and improve accuracy. See the [Layout](#) section for more details.

7.2.1.2.1 Shunt Resistor Sizing

Use Ohm's Law to calculate the voltage drop across the shunt resistor (V_{SHUNT}) for the desired measured current: $V_{SHUNT} = I \times R_{SHUNT}$.

Consider the following two restrictions to choose the proper value of the shunt resistor, R_{SHUNT} :

- Make sure the voltage drop caused by the nominal current range does not exceed the recommended differential input voltage range for a linear response. In other words, $|V_{SHUNT}| \leq V_{FSR}$.
- Make sure the voltage drop caused by the maximum allowed overcurrent does not exceed the input voltage that causes a clipping output. That is, $|V_{SHUNT}| \leq |V_{Clipping}|$.

7.2.1.2.2 Input Filter Design

Place an RC filter in front of a $\Delta\Sigma$ modulator to improve signal-to-noise performance of the signal path. Design the input filter such that:

- The cutoff frequency of the filter is at least one order of magnitude lower than the sampling frequency of the $\Delta\Sigma$ modulator (f_{CLKIN})
- The input bias current does not generate significant voltage drop across the DC impedance of the input filter
- The impedances measured from the analog inputs are equal ($R1$ equals $R2$)

Capacitors C11 and C12 are optional and improve common-mode rejection at high frequencies (>1MHz). For best performance, make sure C11 matches the value of C12 and that both capacitors are 10 to 20 times lower in value than C10. For most applications, the structure shown in [Figure 7-2](#) achieves excellent performance.

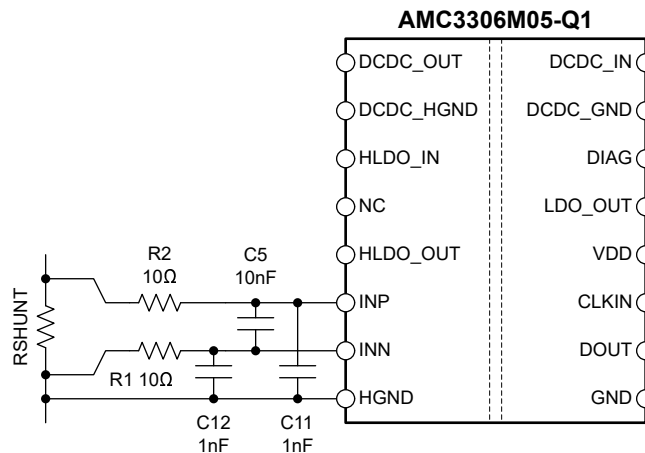

Figure 7-2. Differential Input Filter

7.2.1.2.3 Bitstream Filtering

For modulator output bitstream filtering, select a device from TI's [C2000™](#) or [Sitara™](#) microcontroller families. These families support up to eight channels of dedicated hardwired filter structures that significantly simplify system level design by offering two filtering paths per channel. One path provides high-accuracy results for the control loop and the other is a fast-response path for overcurrent detection.

A [delta sigma modulator filter calculator](#) is available for download at www.ti.com. This calculator aids in filter design and selecting the right OSR and filter order to achieve the desired output resolution and filter response time.

7.2.1.3 Application Curve

The effective number of bits (ENOB) is often used to compare the performance of ADCs and $\Delta\Sigma$ modulators. [Figure 7-3](#) shows the ENOB of the AMC3306M05-Q1 with different oversampling ratios. By using [Equation 3](#), this number is also calculated from the SINAD:

$$\text{SINAD} = 1.76\text{dB} + 6.02\text{dB} \times \text{ENOB} \quad (3)$$

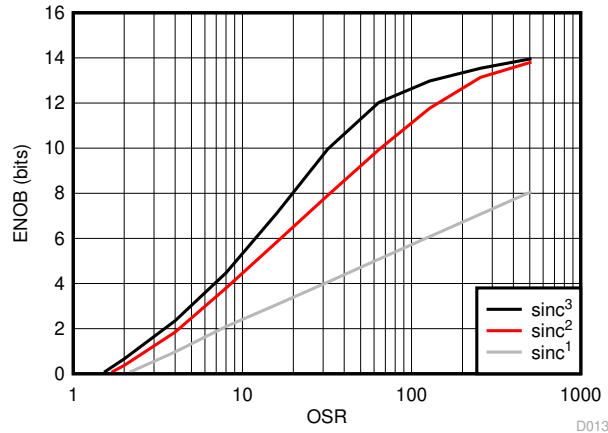

Figure 7-3. Measured Effective Number of Bits vs Oversampling Ratio

7.2.2 Best Design Practices

Do not leave the inputs of the AMC3306M05-Q1 unconnected (floating) when the device is powered up. If left floating, the input bias currents potentially drive the inputs to a positive value that exceeds the operating common-mode input voltage. As a result, the output of the device is undetermined.

Connect the negative input (INN) to the high-side ground (HGND), either by a hard short or through a resistive path. A DC current path between INN and HGND is required to define the input common-mode voltage. Take care not to exceed the input common-mode range as specified in the [Recommended Operating Conditions](#) table. For best accuracy, route the ground connection as a separate trace. Connect this trace directly to the shunt resistor rather than shorting AGND to INN directly at the input to the device. See the [Layout](#) section for more details.

The high-side LDO is capable of sourcing a limited amount of current (I_H) to power external circuitry. Do not overload the high-side LDO and be aware of derating I_H at high temperatures, as explained in the [Isolated DC/DC Converter](#) section.

The low-side LDO does not output a constant voltage and is not intended for powering any external circuitry. Do not connect any external load to the LDO_OUT pin.

7.3 Power Supply Recommendations

The AMC3306M05-Q1 is powered from the low-side power supply (VDD) with a nominal value of 3.3V or 5V. Place a low-ESR, 1nF decoupling capacitor (C8 in Figure 7-4) as close as possible to the VDD pin. Follow the 1nF capacitor with a 1μF capacitor (C9) to filter this power-supply path.

Decouple the low side of the DC/DC converter with a low-ESR, 100nF capacitor (C4) positioned close to the device between the DCDC_IN and DCDC_GND pins. Use a 1μF capacitor (C2) to decouple the high side. Additionally, place a low-ESR, 1nF capacitor (C3) as close as possible to the device and connect this capacitor to the DCDC_OUT and DCDC_HGND pins.

For the high-side LDO, use low-ESR, 1nF capacitors (C6), placed as close as possible to the AMC3306M05-Q1, followed by a 100nF decoupling capacitor (C5).

The ground reference for the high side (HGND) is derived from the terminal of the shunt resistor connected to the device negative input (INN). For best DC accuracy, use a separate trace to make this connection instead of shorting HGND to INN directly at the device input. The high-side DC/DC ground terminal (DCDC_HGND) is shorted to HGND directly at the device pins.

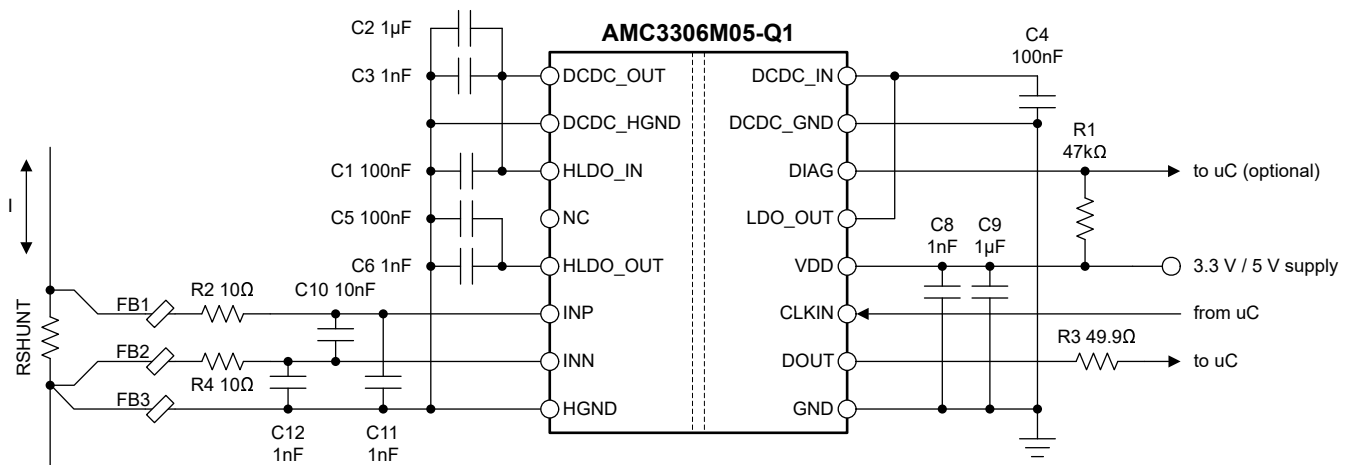

Figure 7-4. Decoupling the AMC3306M05-Q1

Make sure capacitors provide adequate *effective* capacitance under the applicable DC bias conditions experienced in the application. MLCC capacitors typically exhibit only a fraction of the nominal capacitance under real-world conditions; take this factor into consideration when selecting these capacitors. This problem is especially acute in low-profile capacitors, in which the dielectric field strength is higher than in taller components. Reputable capacitor manufacturers provide capacitance versus DC bias curves that greatly simplify component selection.

The [Best Practices to Attenuate AMC3301 Family Radiated Emissions EMI application note](#) is available for download at www.ti.com.

Table 7-2 lists recommended components for use with the AMC3306M05-Q1. This list is not exhaustive. Other components potentially exist that are equally capable (or better), however these listed components have been validated during the development of the AMC3306M05-Q1.

Table 7-2. Recommended External Components

DESCRIPTION	PART NUMBER	MANUFACTURER	SIZE (EIA, L × W)	
VDD				
C8	1nF ± 10%, X7R, 50V	12065C102KAT2A ⁽¹⁾	AVX	1206, 3.2mm × 1.6mm
		C0603C102K5RACTU	Kemet	0603, 1.6mm × 0.8mm
C9	1μF ± 10%, X7R, 25V	12063C105KAT2A ⁽¹⁾	AVX	1206, 3.2mm × 1.6mm
		CGA3E1X7R1E105K080AC	TDK	0603, 1.6mm × 0.8mm
DC/DC CONVERTER				
C4	100nF ± 10%, X7R, 50V	C0603C104K5RACAUTO	Kemet	0603, 1.6mm × 0.8mm
C3	1nF ± 10%, X7R, 50V	C0603C102K5RACTU	Kemet	0603, 1.6mm × 0.8mm
C2	1μF ± 10%, X7R, 25V	CGA3E1X7R1E105K080AC	TDK	0603, 1.6mm × 0.8mm
HLDO				
C1	100nF ± 10%, X7R, 50V	C0603C104K5RACAUTO	Kemet	0603, 1.6mm × 0.8mm
C5	100nF ± 5%, NP0, 50V	C3216NP01H104J160AA ⁽¹⁾	TDK	1206, 3.2mm × 1.6mm
	100nF ± 10%, X7R, 50V	C0603C104K5RACAUTO	Kemet	0603, 1.6mm × 0.8mm
C6	1nF ± 10%, X7R, 50V	12065C102KAT2A ⁽¹⁾	AVX	1206, 3.2mm × 1.6mm
		C0603C102K5RACTU	Kemet	0603, 1.6mm × 0.8mm
FERRITE BEADS				
FB1,FB2, FB3	Ferrite bead ⁽²⁾	74269244182	Würth Elektronik	0402, 1.0mm × 0.5mm
		BLM15HD182SH1	Murata	0402, 1.0mm × 0.5mm
		BKH1005LM182-T	Taiyo Yuden	0402, 1.0mm × 0.5mm

(1) Component used for parametric validation.

(2) No ferrite beads used for parametric validation.

7.4 Layout

7.4.1 Layout Guidelines

Figure 7-5 shows a layout recommendation with the critical placement of the decoupling capacitors and all other components required by the device. Make sure to place the decoupling capacitors as close as possible to the AMC3306M05-Q1 supply pins. For best performance, place the shunt resistor close to the INP and INN inputs of the AMC3306M05-Q1 and keep the layout of both connections symmetrical.

This layout is used on the AMC3306M05-Q1 EVM and supports CISPR-11 compliant electromagnetic radiation levels.

7.4.2 Layout Example

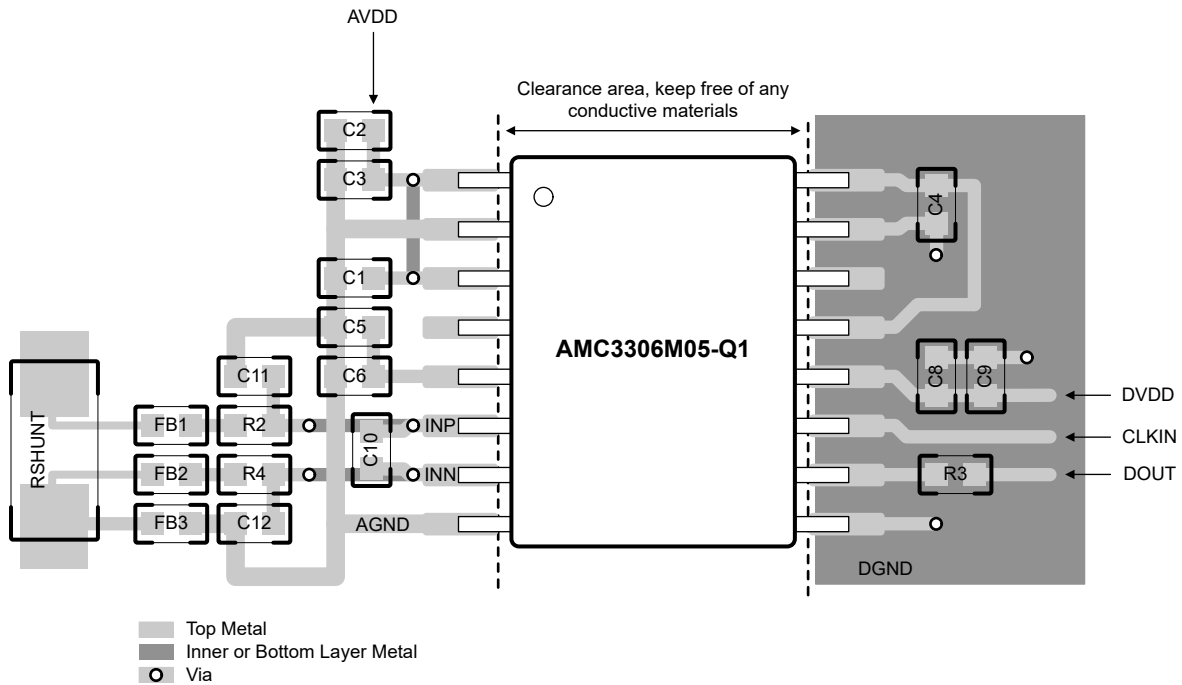

Figure 7-5. Recommended Layout of the AMC3306M05-Q1

8 Device and Documentation Support

8.1 Documentation Support

8.1.1 Related Documentation

For related documentation see the following:

- Texas Instruments, [Isolation Glossary application note](#)
- Texas Instruments, [Semiconductor and IC Package Thermal Metrics application note](#)
- Texas Instruments, [ISO72x Digital Isolator Magnetic-Field Immunity application note](#)
- Texas Instruments, [Delta Sigma Modulator Filter Calculator design tool](#)

8.2 Receiving Notification of Documentation Updates

To receive notification of documentation updates, navigate to the device product folder on [ti.com](#). Click on [Notifications](#) to register and receive a weekly digest of any product information that has changed. For change details, review the revision history included in any revised document.

8.3 Support Resources

[TI E2E™ support forums](#) are an engineer's go-to source for fast, verified answers and design help — straight from the experts. Search existing answers or ask your own question to get the quick design help you need.

Linked content is provided "AS IS" by the respective contributors. They do not constitute TI specifications and do not necessarily reflect TI's views; see TI's [Terms of Use](#).

8.4 Trademarks

C2000™, Sitara™, and TI E2E™ are trademarks of Texas Instruments. All trademarks are the property of their respective owners.

8.5 Electrostatic Discharge Caution



This integrated circuit can be damaged by ESD. Texas Instruments recommends that all integrated circuits be handled with appropriate precautions. Failure to observe proper handling and installation procedures can cause damage.

ESD damage can range from subtle performance degradation to complete device failure. Precision integrated circuits may be more susceptible to damage because very small parametric changes could cause the device not to meet its published specifications.

8.6 Glossary

[TI Glossary](#) This glossary lists and explains terms, acronyms, and definitions.

9 Revision History

NOTE: Page numbers for previous revisions may differ from page numbers in the current version.

DATE	REVISION	NOTES
August 2024	*	Initial Release

10 Mechanical, Packaging, and Orderable Information

The following pages include mechanical, packaging, and orderable information. This information is the most current data available for the designated devices. This data is subject to change without notice and revision of this document. For browser-based versions of this data sheet, refer to the left-hand navigation.

IMPORTANT NOTICE AND DISCLAIMER

TI PROVIDES TECHNICAL AND RELIABILITY DATA (INCLUDING DATA SHEETS), DESIGN RESOURCES (INCLUDING REFERENCE DESIGNS), APPLICATION OR OTHER DESIGN ADVICE, WEB TOOLS, SAFETY INFORMATION, AND OTHER RESOURCES "AS IS" AND WITH ALL FAULTS, AND DISCLAIMS ALL WARRANTIES, EXPRESS AND IMPLIED, INCLUDING WITHOUT LIMITATION ANY IMPLIED WARRANTIES OF MERCHANTABILITY, FITNESS FOR A PARTICULAR PURPOSE OR NON-INFRINGEMENT OF THIRD PARTY INTELLECTUAL PROPERTY RIGHTS.

These resources are intended for skilled developers designing with TI products. You are solely responsible for (1) selecting the appropriate TI products for your application, (2) designing, validating and testing your application, and (3) ensuring your application meets applicable standards, and any other safety, security, regulatory or other requirements.

These resources are subject to change without notice. TI grants you permission to use these resources only for development of an application that uses the TI products described in the resource. Other reproduction and display of these resources is prohibited. No license is granted to any other TI intellectual property right or to any third party intellectual property right. TI disclaims responsibility for, and you will fully indemnify TI and its representatives against, any claims, damages, costs, losses, and liabilities arising out of your use of these resources.

TI's products are provided subject to [TI's Terms of Sale](#) or other applicable terms available either on [ti.com](https://www.ti.com) or provided in conjunction with such TI products. TI's provision of these resources does not expand or otherwise alter TI's applicable warranties or warranty disclaimers for TI products.

TI objects to and rejects any additional or different terms you may have proposed.

Mailing Address: Texas Instruments, Post Office Box 655303, Dallas, Texas 75265
Copyright © 2024, Texas Instruments Incorporated