

TAS2574 8.5W Digital Input Smart Amp with I/V Sense and Integrated 15V Class-H Boost

1 Features

- Powerful class-D amplifier
 - 8.5W 1% THD+N
 - 15V boost with 5.1A max current limit
- Best in class efficiency
 - Upto 90% efficiency at system level
 - 4.8mW idle channel power
 - Integrated Y-bridge
 - Advanced 33mV step size class-H boost
- High performance audio channel
 - 4.2 μ V A-wt. idle channel noise
 - 114dB Dynamic Range
 - -90dB THDN
 - Low EMI performance
- Advanced integrated features
 - Integrated Speaker IV sense
 - Signal detection high efficiency modes
 - High accuracy voltage monitor & temp sensor
 - Programmable battery input current limit
- Ease of use features
 - 1cell, 2cell and 3cell Li-ion battery support
 - Clock based power up/down
 - Auto clock rate detection: 16kHz to 192kHz
 - Integrated ultrasonic tone and chirp generator
 - External 14V PVDD supply support
 - MCLK free operation
 - Thermal and over current protection
 - Programmable drive strength IO buffers
- Power Supplies and user interface
 - Battery Voltage: 1.8V to 5.5V
 - VDD: 1.65V to 1.95V
 - IOVDD: 1.2V or 1.8V
 - I²S/TDM: 8 channels
 - I²C: 4 selectable addresses
- WCSP package

2 Applications

- [Mobile phone, Tablets & Wearables](#)
- [Smart Speakers with Voice Assistance](#)
- [Bluetooth and Wireless speakers](#)

3 Description

The TAS2574 is a digital input Class-D audio amplifier with an integrated Boost for higher power delivery in battery-operated systems. The device has integrated speaker voltage and current sense (IV-Sense) for real-time monitoring of the loudspeakers. IV-sense data can be used to run speaker protection algorithms on a host DSP to enable high output SPL while keeping speakers in a safe operating region.

The device is optimized for delivering the best battery life for real use cases of Music playback and Voice calls. Advanced efficiency optimization features like Class-H, Y-bridge and algorithms enable the device to produce best-in-class efficiency across all power regions of operation. The Class-D amplifier is capable of delivering 8.5W output power using the integrated Class-H 15V Boost.

A battery tracking peak voltage limiter and a battery voltage monitor ADC enables advanced battery monitoring algorithms on the host processor to manage peak output power delivery while avoiding any audio distortion when battery capacity is depleting.

Up to four devices can share a common bus via I²S/TDM + I²C interfaces.

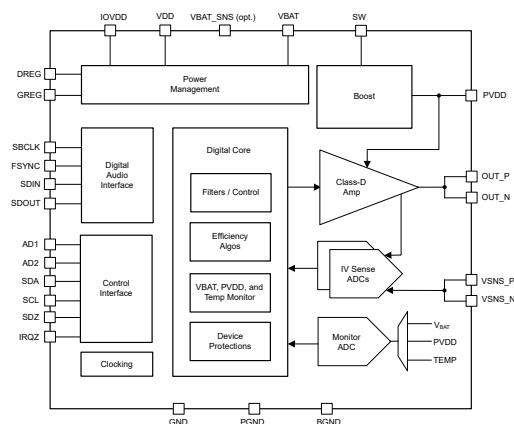

Functional block diagram



Table of Contents

1 Features	1	6.2 Receiving Notification of Documentation Updates.....	5
2 Applications	1	6.3 Support Resources.....	5
3 Description	1	6.4 Trademarks.....	5
4 Pin Configuration and Functions	2	6.5 Electrostatic Discharge Caution.....	5
5 Revision History	3	6.6 Glossary.....	5
6 Device and Documentation Support	5	7 Mechanical, Packaging, and Orderable Information	6
6.1 Documentation Support.....	5		

4 Pin Configuration and Functions

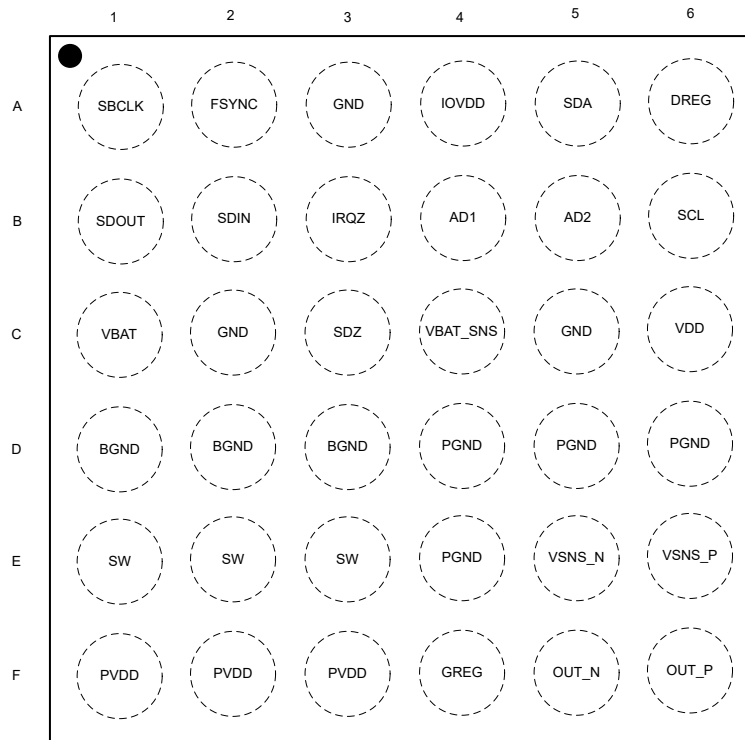

Notes: - Not to Scale

Figure 4-1. Package Top Level View Pinout

Pin Functions

PIN		Type ¹	DESCRIPTION
NAME	NO.		
AD1	B4	I	I ² C address pin LSB.
AD2	B5	I	I ² C address pin LSB+1.
BGND	D1	P	Boost ground. Connect to PCB GND plane strongly with multiple vias.
	D2		
	D3		
DREG	A6	P	Digital core voltage regulator output. Bypass to GND with a capacitor. Do not connect to external load.
FSYNC	A2	I	I ² S word clock or TDM frame sync.
GREG	F4	P	High-side gate CP regulator output. Do not connect to external load.
GND	A3	P	Digital ground. Connect to PCB GND plane. Strong connection to ground plane required through multiple vias.
	C2		
	C5		
IOVDD	A4	P	1.2V or 1.8V Digital IO supply. Decouple to GND with capacitor.
IRQZ	B3	O	Open drain, active low interrupt pin. Pull up to IOVDD with resistor if optional internal pullup is not used.
OUT_N	F5	O	Class-D negative output.
OUT_P	F6	O	Class-D positive output.
PGND	D4	P	Class-D Power stage ground. Connect to PCB GND plane strongly through multiple vias.
	D5		
	D6		
	E4		
PVDD	F1	P	Integrated boost output and Class-D power stage supply.
	F2		
	F3		
SBCLK	A1	I	I ² S/TDM serial bit clock.
SCL	B6	I	I ² C Clock Pin. Pull up to IOVDD with a resistor.
SDA	A5	I/O	I ² C Data Pin. Pull up to IOVDD with a resistor.
SDIN	B2	I	I ² S or TDM serial data input.
SDOUT	B1	I/O	I ² S or TDM serial data output.
SDZ	C3	I	Active low hardware shutdown.
SW	E1	P	Boost converter switch input.
	E2		
	E3		
VBAT	C1	P	Battery power supply input. Connect to 2.5V to 5.5V supply and decouple with a capacitor.
VBAT_SNS	C4	I	Battery sense terminal. Connect to 1S or 2S battery supply for remote battery sensing. Ground the pin if remote sensing is not used.
VDD	C6	P	Analog, digital power supply. Connect to 1.8V supply and decouple to GND with capacitor.
VSNS_N	E5	I	Voltage sense negative input. Connect to speaker negative terminal as close to speaker as possible. Add series resistor if EMI filter is used.
VSNS_P	E6	I	Voltage sense positive input. Connect to speaker positive terminal as close to speaker as possible. Add series resistor if EMI filter is used.

1. I = Input, O = Output, I/O = Input or Output, G = Ground, P = Power.

5 Revision History

NOTE: Page numbers for previous revisions may differ from page numbers in the current version.

DATE	REVISION	NOTES
August 2024	*	Initial Release

6 Device and Documentation Support

TI offers an extensive line of development tools. Tools and software to evaluate the performance of the device, generate code, and develop solutions are listed below.

6.1 Documentation Support

6.1.1 Related Documentation

For related documents see the following

- Texas Instruments, [Purepath Console 3 \(PPC3\) Software](#)

6.2 Receiving Notification of Documentation Updates

To receive notification of documentation updates, navigate to the device product folder on [ti.com](#). Click on *Notifications* to register and receive a weekly digest of any product information that has changed. For change details, review the revision history included in any revised document.

6.3 Support Resources

[TI E2E™ support forums](#) are an engineer's go-to source for fast, verified answers and design help — straight from the experts. Search existing answers or ask your own question to get the quick design help you need.

Linked content is provided "AS IS" by the respective contributors. They do not constitute TI specifications and do not necessarily reflect TI's views; see TI's [Terms of Use](#).

6.4 Trademarks

TI E2E™ is a trademark of Texas Instruments.

All trademarks are the property of their respective owners.

6.5 Electrostatic Discharge Caution



This integrated circuit can be damaged by ESD. Texas Instruments recommends that all integrated circuits be handled with appropriate precautions. Failure to observe proper handling and installation procedures can cause damage.

ESD damage can range from subtle performance degradation to complete device failure. Precision integrated circuits may be more susceptible to damage because very small parametric changes could cause the device not to meet its published specifications.

6.6 Glossary

[TI Glossary](#) This glossary lists and explains terms, acronyms, and definitions.

7 Mechanical, Packaging, and Orderable Information

The following pages include mechanical, packaging, and orderable information. This information is the most current data available for the designated devices. This data is subject to change without notice and revision of this document. For browser-based versions of this data sheet, refer to the left-hand navigation.

IMPORTANT NOTICE AND DISCLAIMER

TI PROVIDES TECHNICAL AND RELIABILITY DATA (INCLUDING DATA SHEETS), DESIGN RESOURCES (INCLUDING REFERENCE DESIGNS), APPLICATION OR OTHER DESIGN ADVICE, WEB TOOLS, SAFETY INFORMATION, AND OTHER RESOURCES "AS IS" AND WITH ALL FAULTS, AND DISCLAIMS ALL WARRANTIES, EXPRESS AND IMPLIED, INCLUDING WITHOUT LIMITATION ANY IMPLIED WARRANTIES OF MERCHANTABILITY, FITNESS FOR A PARTICULAR PURPOSE OR NON-INFRINGEMENT OF THIRD PARTY INTELLECTUAL PROPERTY RIGHTS.

These resources are intended for skilled developers designing with TI products. You are solely responsible for (1) selecting the appropriate TI products for your application, (2) designing, validating and testing your application, and (3) ensuring your application meets applicable standards, and any other safety, security, regulatory or other requirements.

These resources are subject to change without notice. TI grants you permission to use these resources only for development of an application that uses the TI products described in the resource. Other reproduction and display of these resources is prohibited. No license is granted to any other TI intellectual property right or to any third party intellectual property right. TI disclaims responsibility for, and you will fully indemnify TI and its representatives against, any claims, damages, costs, losses, and liabilities arising out of your use of these resources.

TI's products are provided subject to [TI's Terms of Sale](#) or other applicable terms available either on [ti.com](https://www.ti.com) or provided in conjunction with such TI products. TI's provision of these resources does not expand or otherwise alter TI's applicable warranties or warranty disclaimers for TI products.

TI objects to and rejects any additional or different terms you may have proposed.

Mailing Address: Texas Instruments, Post Office Box 655303, Dallas, Texas 75265
Copyright © 2024, Texas Instruments Incorporated